



VITREOUS CHINA

TOILET  
**21-912**

LAVATORIES

TOILETS

BIDETS / URINALS

CAST IRON

# MAXWELL® 1.28 Elongated Toilet

12" Rough-in

### Features:

- 1.28 gpf/4.8 Lpf high efficiency two-piece toilet
- Elongated bowl
- Dual-fed siphon jet
- Pilot fill valve
- 3" flush valve
- 2" glazed trapway
- Color matched front tank lever (white only)
- Optional insulated non-sweating tank
- Optional right-handed trip lever
- Available in White, Bone and Biscuit
- 2 bolt caps



**Specifications:** Bowl—#21-962 Elongated Bowl Tank—#28-990  
Seat not included

### Dimensions:

- Height .....28"
- Width ..... 17 1/2"
- Depth ..... 28 1/8"
- Rough-in.....12"
- Water Surface from Rim .....5 7/8"
- Trapway ..... 2"
- Water Surface ..... 10 7/8" x 7 1/2"
- Water Seal .....2 3/8"
- Shipping Weight ..... 79.5 lbs

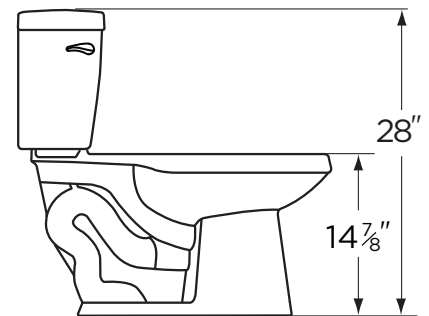
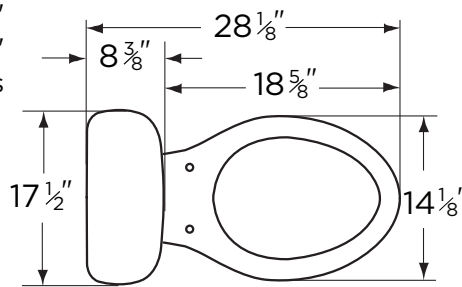

THIS FIXTURE QUALIFIES ACCORDING TO ASME TEST PROCEDURES AS A HIGH EFFICIENCY WATER CLOSET WITH AN AVERAGE CONSUMPTION OF 1.28 gpf (4.8 Lpf) OR LESS.

HIGH EFFICIENCY TOILET  
**HET**

www.gerberonline.com

Job Name	
Date	
Model Specified	
Quantity	
Customer	
Contractor	
Architect/engineer	



1.28 gpf (4.8 Lpf) MAXWELL® 1.28 TOILET

21-912  
Elongated, 12" Rough-in  
(Bowl 21-962 with Tank 28-990)

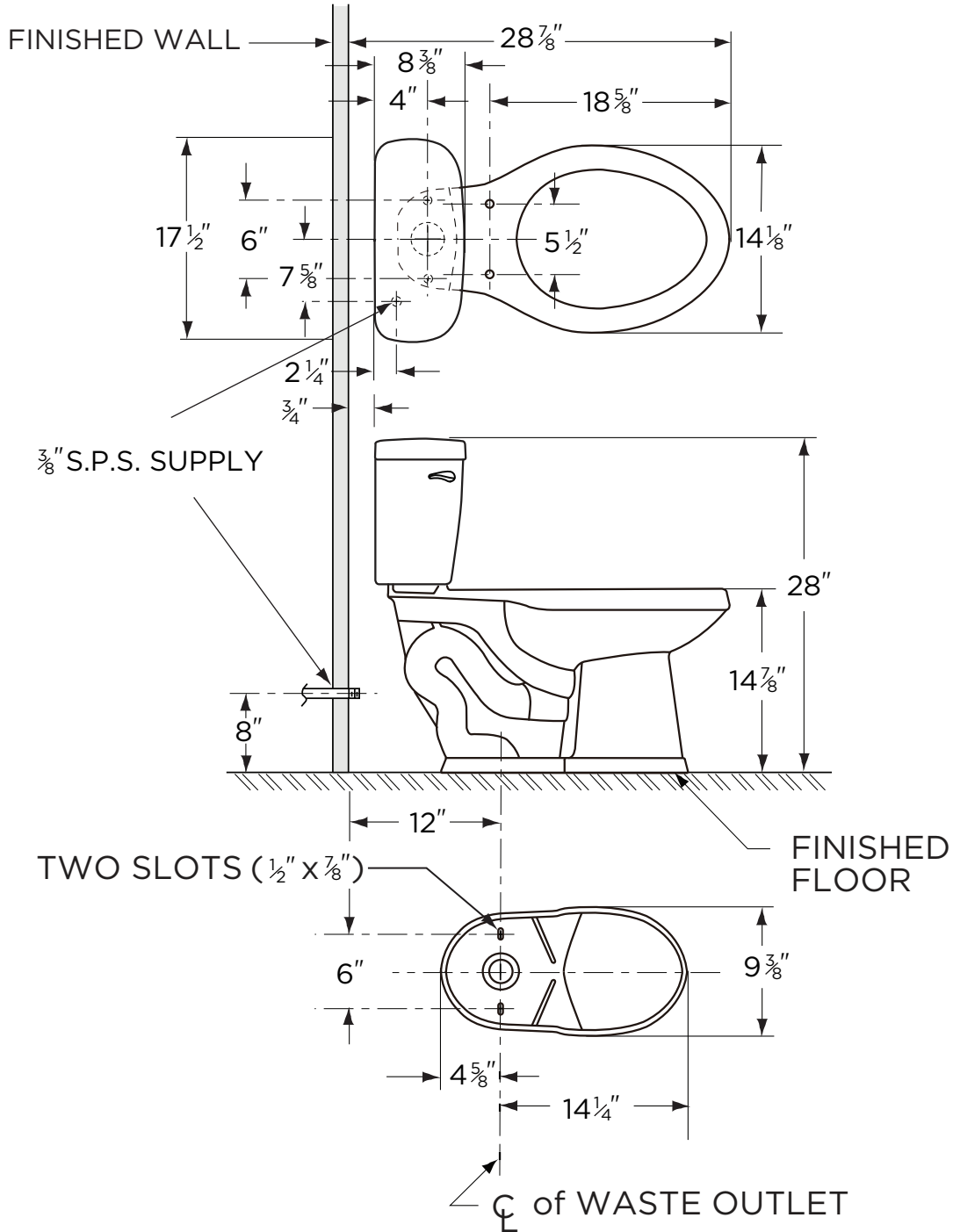

NOTES:  
All dimensions are in inches.  
Illustrations may not be drawn to scale.

IMPORTANT:  
Dimensions of fixtures are nominal and may vary within the range of tolerances established by ASME Standard A 112.19.2.  
THIS FIXTURE QUALIFIES ACCORDING TO ASME TEST PROCEDURES AS A HIGH EFFICIENCY WATER CLOSET WITH AN AVERAGE CONSUMPTION OF 1.28 gpf (4.8 Lpf) OR LESS.