

# Model SF

## OIL BURNER

### Chassis Plan

- Reduces Investment Up To 65%
- Reduces Storage Space Up To 85%
- Speeds Service Calls

The Beckett Chassis Plan lets you stock a minimum number of oil burners and still get maximum installation flexibility. The chassis represents up to 90% of the total burner cost, but a single chassis adapts to all firing rates commonly encountered in upgrading and replacement jobs.

To a minimum chassis stock, you add an assortment of air tube combinations. From this assortment, you can choose the precise combination for your application requirements. To complete the installation, simply install the proper support.

### How To Order

#### Order Burner Chassis

1. Model SF Burner Chassis
2. Type of Fuel Unit (single or two-stage)
3. Primary control

#### Order Air Tube Combination

1. Air Tube Length (dimension A) and Firing Rate OR
- Air Tube Combination Code (see table at right)

#### Order Accessories

1. Specify type of supports required.
2. Add any other items such as spare parts, related controls, valves, etc.

### Fully Approved

Listed by Underwriters' Laboratories, Inc.  
Accepted by New York City M.E.A.  
Approved by Commonwealth of Massachusetts  
C.S.A. Certified

### Optional Supports

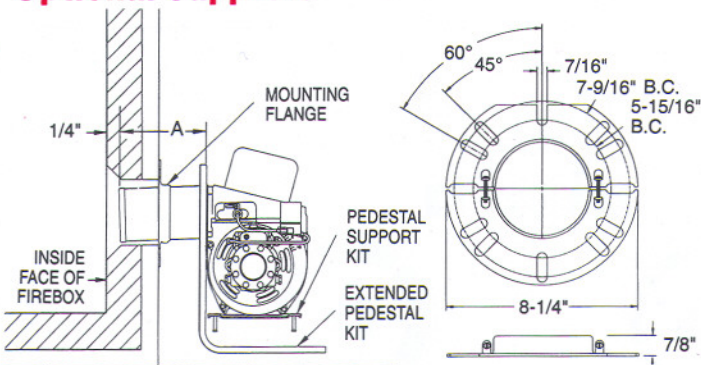

#### No. 5685 Pedestal Support

For conversion applications.

No mounting flange is required.

Note: Part No. 5606 Extended Pedestal Support is also available, and provides elevation from 8-1/4" to 13".

#### No. 5850 or 5432 Adjustable Mounting Flange Kit

No. 5850 is a two-piece split flange.

No. 5432 is a one-piece flange.

Both kits include a flange mounting gasket.

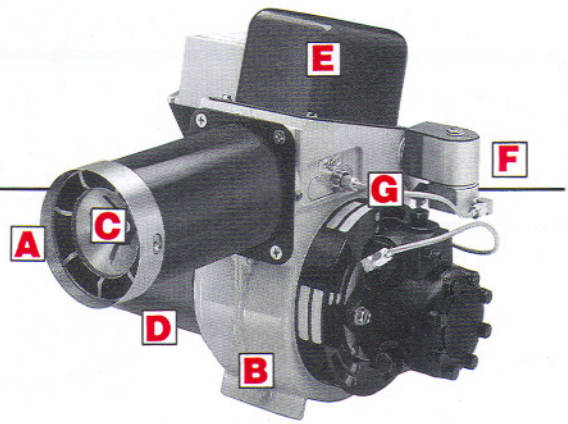

- A ONE-PIECE FLAME RETENTION HEAD**  
The highly stable flame and the intense combustion increases fuel efficiency as much as 35%.
- B STURDY DIE-CAST ALUMINUM HOUSING**  
The precisely machined, die cast aluminum housing aligns the pump and motor for smooth operation and long coupling life.
- C NOZZLE LINE ELECTRODE ASSEMBLY**  
Self-centering design delivers oil to the nozzle and high voltage electricity to the electrodes. Air flow to the head is controlled and evened out by a static plate for smooth, efficient combustion.
- D DRIVE MOTOR**  
A continuous duty, split phase motor is built for daily hard use and years of trouble free operation. Overload protection standard.
- E IGNITION TRANSFORMER**  
10,000 volts and 23 milliamps positively and smoothly ignite the fuel. No TV interference. Designed for heavy duty continuous operation.
- F SOLENOID VALVE**  
Provides rapid oil cutoff at the end of heat call. This reduces smoke and contributes to quieter, smoother operation.
- G CONNECTOR TUBE FITTING**  
A high quality flare fitting standard with Beckett.

### Model SF Air Tube Combination Codes

FIRING RATE MIN-MAX G.P.H.	BURNER HEAD	USABLE AIR TUBE LENGTH "A"		
		6-5/8"	7-1/4"	9"
1.25 - 2.25	F12	SF65FO	SF72FO	SF90FO
1.75 - 3.25	F22	SF65FP	SF72FP	SF90FP
2.50 - 5.50	F310	SF65FT	SF72FT	SF90FT

FIRING RATE MIN-MAX G.P.H.	BURNER HEAD	USABLE AIR TUBE LENGTH "A"	
		13"	16"
1.25 - 2.25	F12	SF130FO	SF160FO
1.75 - 3.25	F22	SF130FP	SF160FP
2.50 - 5.50	F310	SF130FT	SF160FT

### To Determine Air Tube Length

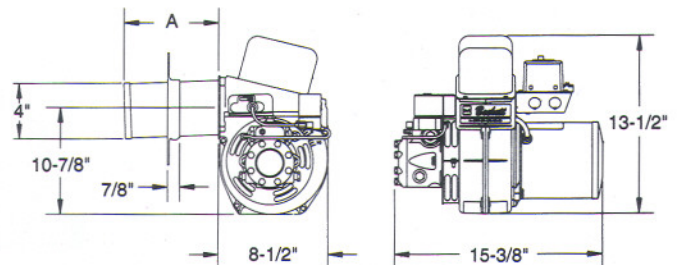

The Air Tube Length (Dimension A) is the distance from the front of the burner housing to the end of the air tube.



Form No. 6193 R794  
© 1994 R.W. Beckett Corporation  
Printed in U.S.A.