

MOLDED

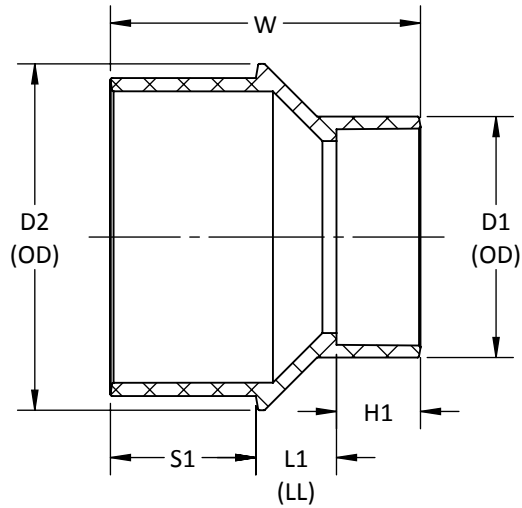

ASTM D2665, F1866, CSA B181.2 WHERE APPLICABLE

**CONCENTRIC REDUCER BUSHING SxH
PVC SOLVENT WELD DWV**

PART NO.	SIZE IN INCHES	L1	H1	S1	W	D1	D2
* D1216	6 x 4	1 17/32	1 25/32	3 1/16	6 3/8	5 1/32	7 7/32
* D1217	8 x 4	2 13/32	1 25/32	4 1/16	8 1/4	5 1/32	9 1/8
* D1218	8 x 6	1 19/32	3 1/16	4 1/16	8 23/32	7 7/32	9 1/8
* D1210-4	10 x 4	2 5/32	1 25/32	5 1/16	9	5 1/32	11 3/16
* D1210-6	10 x 6	1 9/16	3 1/16	5 1/16	9 11/16	7 7/32	11 1/2
* D1210-8	10 x 8	1 3/32	4 1/16	5 1/16	10 7/32	9 11/32	11 3/16
* D1212-4	12 x 4	2 3/4	1 25/32	6 1/16	10 19/32	5 1/32	13 9/16
* D1212-6	12 x 6	2 7/32	3 1/16	6 1/16	11 11/32	7 7/32	13 9/16
* D1212-8	12 x 8	1 11/16	4 1/16	6 1/16	11 13/16	9 11/32	13 9/16
* D1212-10	12 x 10	1 1/8	5 1/16	6 1/16	12 1/4	11 17/32	13 9/16

-- DIMENSIONS AND APPEARANCE ARE APPROXIMATE AND SUBJECT TO CHANGE
WITHOUT NOTICE DUE TO DESIGN OR PRODUCTION MODIFICATIONS
-- MOLDED FITTING TOLERANCE = ±1/8" OVERALL LENGTH
-- FABRICATED FITTING TOLERANCE = ±1" LINEAR, ± 2° ANGULAR

* MOLDED FITTING
† ASSEMBLED FROM MOLDED COMPONENTS
ALL OTHER FITTINGS ARE FABRICATED