

# MABEL

## 85572CM

### SMALL TWO LIGHT VANITY

With vintage-inspired vibes, Mabel's clear hobnail glass brightens your décor with a delightfully eclectic style. Versatile Chrome or Lacquered Brass finishes easily fit any bath or living space.

DETAILS	
FINISH:	Chrome
MATERIAL:	Steel
GLASS:	Clear Hobnail
DIMMABLE:	YES - WITH DIMMABLE LAMP (NOT INCLUDED)

DIMENSIONS	
WIDTH:	14"
HEIGHT:	10"
WEIGHT:	4lb
BACK PLATE:	5.25" Dia.
EXTENSION:	6.5"
TOP TO OUTLET:	7.5"

LIGHT SOURCE	
LIGHT SOURCE:	Socketed
WATTAGE:	2-12w Med. LED, 60w Equiv.
VOLTAGE:	120v

SHIPPING	
CARTON LENGTH:	17
CARTON WIDTH:	7.8
CARTON HEIGHT:	13
CARTON WEIGHT:	6.6

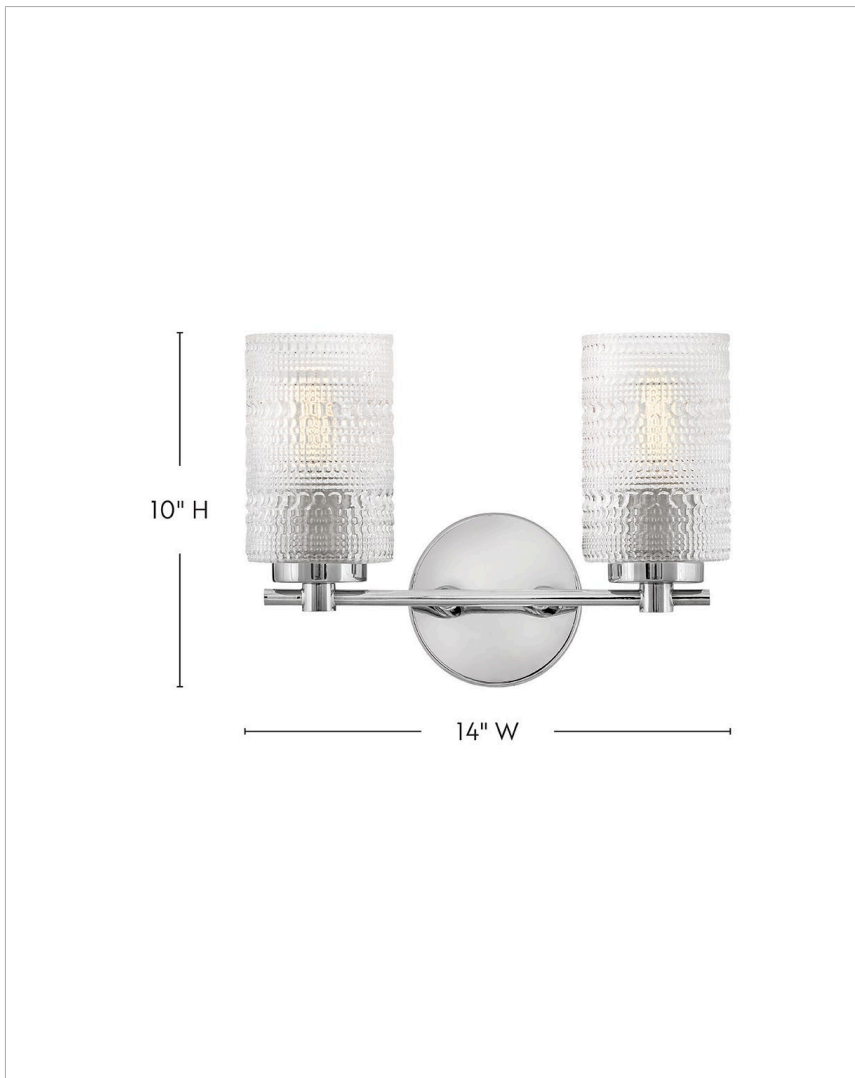

#### PRODUCT DETAILS:

- This versatile transitional design delivers personality and performance
- Please refer to Lark's Warranty for complete product warranty details (some warranty limitations may apply)
- This fixture can be mounted either up or down to best fit your space
- Damp Rated
- This design features a sparkling, reflective chrome finish
- Invisimount hardware is hidden on the backplate for a clean silhouette
- This product uses recyclable or limited packaging materials to help reduce waste