

Product data sheet

Specifications

SQUARE D

Green Premium™



Tandem circuit breaker, Homeline, 2 x 1 pole at 15A, 120/240VAC, 10kA AIR, plug in, UL

HOMT1515CP

Product availability : Stock - Normally stocked in distribution facility

Price* : 52.00 USD

Main

Product	Miniature circuit-breaker
Range	Homeline
Current Rating	15 A
Certifications	UL Listed
Voltage Rating	120/240 V AC
Mounting Type	Plug-in
Number of Poles	1P
Short Circuit Current Rating	10 kA
Number of Spaces	1
Circuit Breaker Type	Tandem
Ratings	HACR rated
Electrical Connection	Box lugs
Wire Size	1 x AWG 14...AWG 8 (aluminium/copper)
Type of Packing	Consumer packaging

Complementary

Tightening torque	35.40 lbf.in (4.0 N.m) 0.00...0.01 in ² (2.5...6 mm ²) (AWG 14...AWG 8)
Height	3.13 in (79.50 mm)
Width	1 in (25.40 mm)
Depth	2.98 in (75.69 mm)

Environment

Ambient air temperature for operation	104 °F (40 °C)
---------------------------------------	----------------

Ordering and shipping details

Category	01322-HOMELINE TANDEM BLK/CARDED
Discount Schedule	CPH
GTIN	047569071058

* Price is "List Price" and may be subject to a trade discount – check with your local distributor or retailer for actual price.

Returnability	Yes
Country of origin	MX

Packing Units

Unit Type of Package 1	PCE
Number of Units in Package 1	1
Package 1 Height	3.00 in (7.62 cm)
Package 1 Width	1.00 in (2.54 cm)
Package 1 Length	3.30 in (8.382 cm)
Package 1 Weight	6.88 oz (195.0 g)
Unit Type of Package 2	BB1
Number of Units in Package 2	10
Package 2 Height	3.50 in (8.89 cm)
Package 2 Width	1.00 in (2.54 cm)
Package 2 Length	10.20 in (25.908 cm)
Package 2 Weight	4.55 lb(US) (2.064 kg)
Unit Type of Package 3	CAR
Number of Units in Package 3	100
Package 3 Height	10.90 in (27.686 cm)
Package 3 Width	7.70 in (19.558 cm)
Package 3 Length	17.50 in (44.45 cm)
Package 3 Weight	46.22 lb(US) (20.965 kg)

Offer Sustainability

Sustainable offer status	Green Premium product
REACH Regulation	REACH Declaration
EU RoHS Directive	Compliant EU RoHS Declaration
Toxic heavy metal free	Yes
Mercury free	Yes
China RoHS Regulation	China RoHS declaration Pro-active China RoHS declaration (out of China RoHS legal scope)
RoHS exemption information	Yes
Environmental Disclosure	Product Environmental Profile

Dimensions

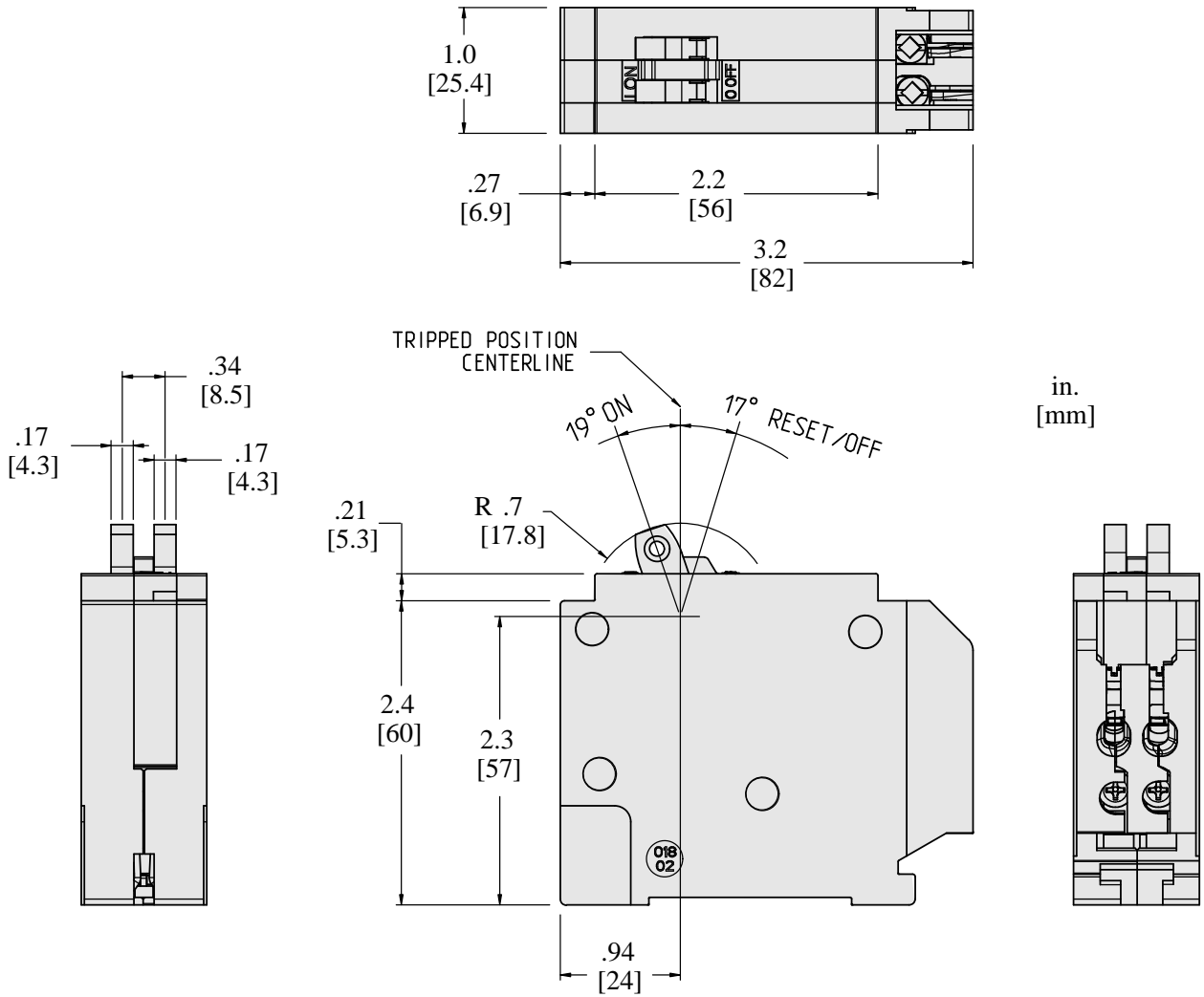

All dimensions are approximate. Also refer to technical drawings and documentation.

Recommended replacement(s)