



Product information presented here reflects conditions at time of publication. Consult factory regarding discrepancies or inconsistencies.

PUMP COMPANY

Zoeller Family of Water Solutions™

MAIL TO: P.O. BOX 16347 • Louisville, KY 40256-0347
 SHIP TO: 3649 Cane Run Road • Louisville, KY 40211-1961
 (502) 778-2731 • 1 (800) 928-PUMP • FAX (502) 774-3624

visit our web site:
www.zoeller.com

SIMPLEX 840 GRINDER SYSTEM

P/N 922-0006 OUTDOOR PREPACKAGED WITH SQUARE GUIDE RAIL SYSTEM

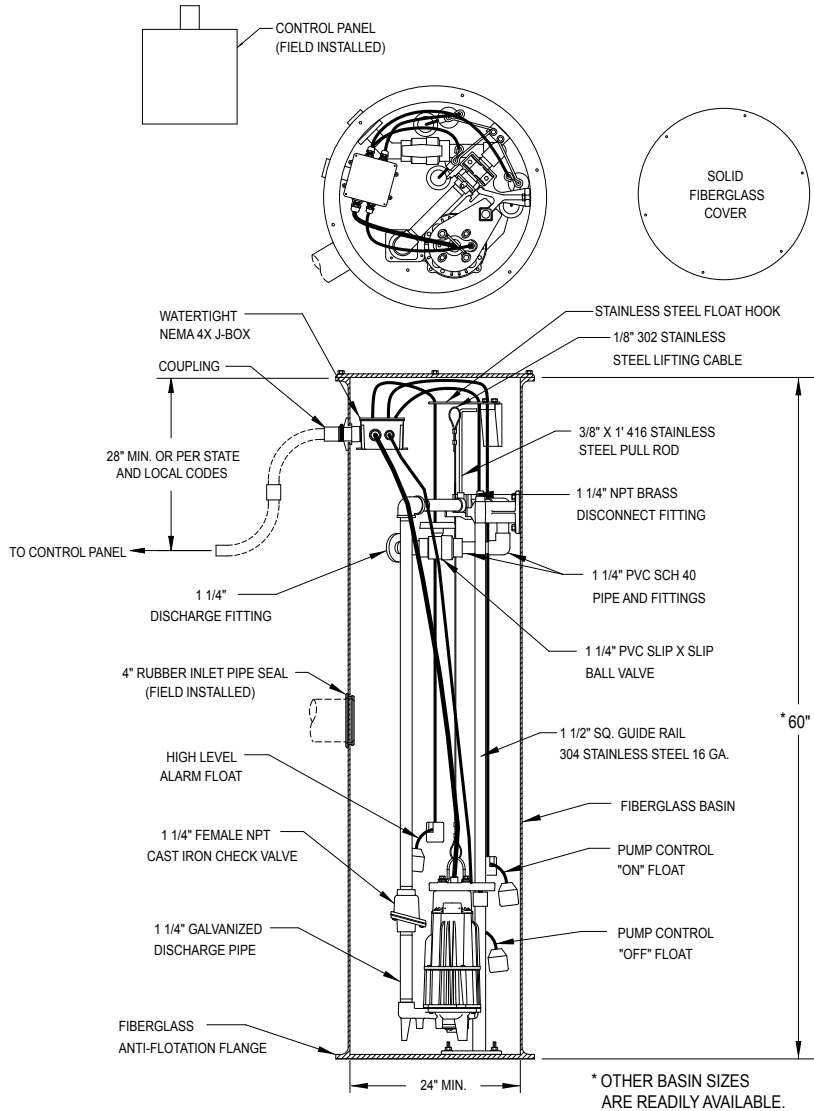

SK1665A

Complete System As Shown Above (P/N 922-0006) Includes:

| Qty. | Part No. | Description |
|------|----------|--|
| 1 | 840-0004 | 230 Volt, 1 Ph, 2 HP Grinder Pump |
| 1 | 10-0393 | Nema 4X Simplex Control Panel with Automatic Reversing (Not Shown) |
| 1 | 10-0329 | Switch Assembly (3) |
| 1 | 10-0331 | J-Box for 3-Float System |
| 1 | 33-0023* | 24" X 60" Fiberglass Basin and Cover, Rail System, 8' SS Lifting Cable and 1' Pull Rod |

Approximate Weight: 390 lbs.

DUPLEX 840 GRINDER SYSTEM

P/N 922-0022 OUTDOOR PREPACKAGED WITH SQUARE GUIDE RAIL SYSTEM

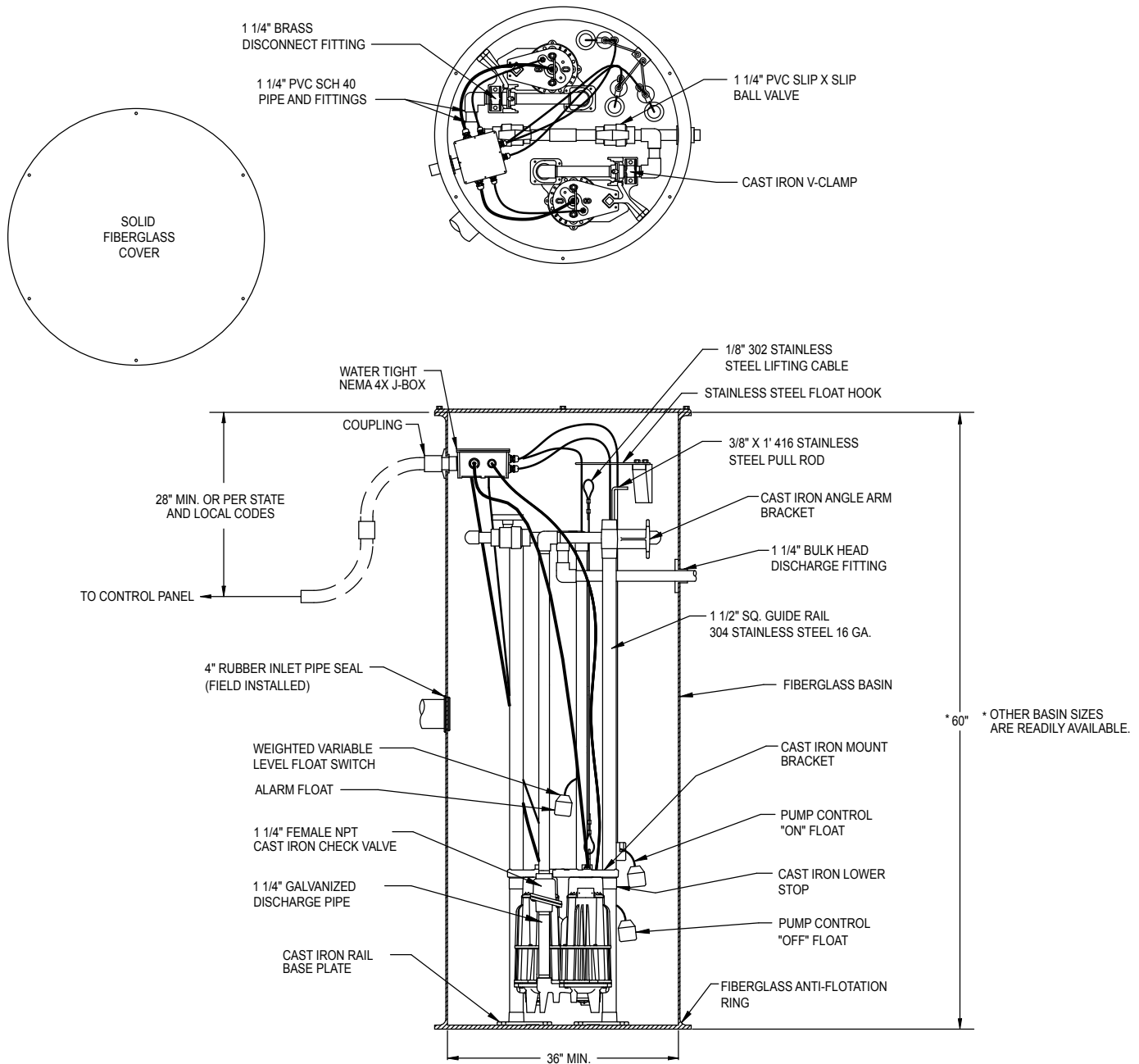

SK1667A

Complete System As Shown Above (P/N 922-0022) Includes:

| Qty. | Part No. | Description |
|------|----------|---|
| 2 | 840-0004 | 230 Volt, 1 Ph, 2 HP Grinder Pumps |
| 1 | 10-0512 | Nema 4X Duplex Control Panel with Automatic Reversing (Not Shown) |
| 1 | 10-0329 | Switch Assembly (3) |
| 1 | 10-0332 | J-Box for 3-Float System |
| 1 | 33-0035* | 36" X 60" Fiberglass Basin and Cover, Rail Systems, Two 8' SS Lifting Cables and Two 1' Pull Rods |

Approximate Weight: 745 lbs.