

76-100 SERIES

Stainless Steel Ball Valve with Mounting Pad 1/4" - 1"

Female NPT Thread, 2000 CWP (psig). Cold Non-Shock. (See referenced P/T chart)
 150 psig Saturated Steam.
 Vacuum Service to 29 inches Hg.
 MSS SP-110 compliant.



FEATURES

- Investment cast components
- Reinforced seats
- Mounting pad for easy actuator mounting
- Blow-out-proof stem design
- Adjustable packing gland
- Stainless Steel lever and nut

- Fire tested API 607, 6th edition (Requires "24" suffix)
- Meets NACE MR0175 (2000) & MR0103 (2012)
- CSA/CAN 3.16-M88 (2009) (Requires "01" suffix)
- NSF/ANSI 61 (2010) Section 8, Annex F & G
- NSF-372, Drinking Water System Components - Lead Content

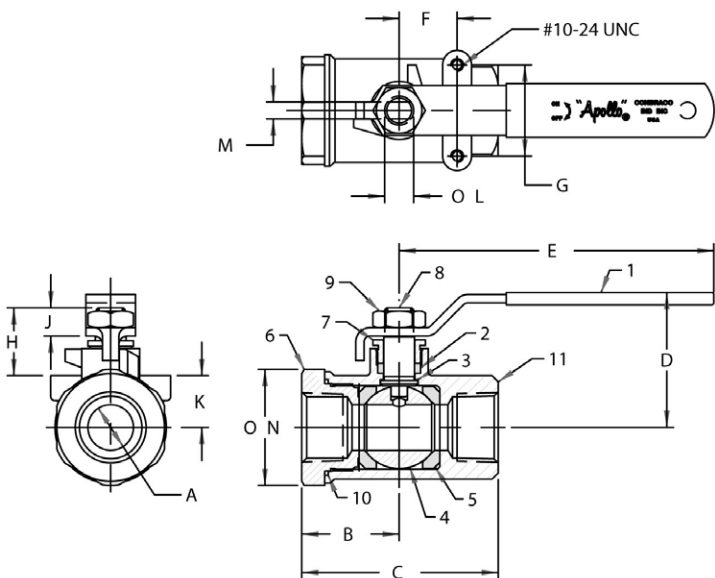

OPTIONS AVAILABLE: (More information in Section J)

(SUFFIX)	OPTION	SIZES
-01	Standard Configuration	All
-P -01-	BSPP (Parallel) Thread Connection	1/4" to 3"
-T -01-	BSPT (Tapered) Thread Connection	1/4" to 3"
-02-	Stem Grounded	1/4" to 3"
-04-	2.25" CS Stem Extension	1/4" to 3"
-07-	Steel Tee Handle	1/4" to 2"
-08-	90° Reversed Stem	1/4" to 3"
-14-	Side Vented Ball (Uni-Directional)	1/4" to 2"
-15-	Wheel Handle, Steel	1/4" to 2"
-16-	Chain Lever - Vertical	3/4" to 2"
-19-	Lock Plate	1/4" to 2"
-21-	UHMWPE Trim (Non-PTFE)	1/4" to 3"
-24-	Graphite Packing	1/4" to 3"
-27-	SS Latch-Lock Lever & Nut	1/4" to 3"
-30-	Cam-Lock and Grounded	1/4" to 2"
-32-	SS Tee Handle & Nut	1/4" to 2"
-35-	PTFE Trim	1/4" to 3"
-39-	SS Hi-Rise Locking Wheel Handle, SS Nut	1/4" to 2"
-40-	Cyl-Loc and Grounded	1/4" to 2"
-44-	Seal Welded	1/4" to 2"
-45-	Less Lever & Nut	1/4" to 3"
-46-	Latch Lock Lever - Lock in Closed Position Only	1/4" to 3"
-47-	SS Latch Lock Oval Handle	1/4" to 2"
-48-	SS Oval Handle (No Latch) & Nut	1/4" to 2"
-49-	No Lubrication. Assembled Dry.	1/4" to 3"
-50-	2.25" CS Locking Stem Extension	1/4" to 3"
-57-	Oxygen Cleaned	1/4" to 3"
-58-	Chain Lever - Horizontal	3/4" to 2"
-60-	Static Grounded Ball & Stem	1/4" to 3"
-64-	250# Steam Trim	1/4" to 3"

STANDARD MATERIAL LIST

PART	MATERIAL	
1	Lever and grip	304 SS w/vinyl
2	Stem packing	MPTFE
3	Stem bearing	RPTFE
4	Ball	A276-316 Stainless Steel
5	Seat (2)	RPTFE
6	Retainer	A351-CF8M Stainless Steel
7	Gland nut	A276-316 Stainless Steel
8	Stem	A276-316 Stainless Steel
9	Lever nut	18-8 Stainless Steel
10	Body seal	PTFE
11	Body	A351-CF8M Stainless Steel

PRODUCT NUMBER	SIZE	A	B	C	D	E	F	G	H	J	K	L	M	N	WT.
76-101-01A	1/4"	0.37	1.02	2.05	1.71	3.85	0.50	1.12	0.88	0.34	0.53	0.375	0.234	1.16	0.58
76-102-01A	3/8"	0.37	1.02	2.05	1.71	3.85	0.50	1.12	0.88	0.34	0.53	0.375	0.234	1.16	0.55
76-103-01A	1/2"	0.50	1.12	2.23	1.79	3.85	0.50	1.12	0.90	0.34	0.59	0.375	0.234	1.38	0.63
76-104-01A	3/4"	0.68	1.47	2.96	2.03	4.75	0.87	1.37	1.02	0.42	0.78	0.437	0.256	1.75	1.30
76-105-01A	1"	0.87	1.67	3.34	2.16	4.75	0.87	1.37	1.02	0.42	0.91	0.437	0.256	1.94	1.60

FOR PRESSURE/TEMPERATURE RATINGS, REFER TO PAGE M-14, GRAPH NO. 14

76-100 SERIES

Stainless Steel Ball Valve with Mounting Pad 1.25" - 2"

Female NPT Thread, 1500 CWP (psig). Cold Non-Shock. (See referenced P/T chart)
 150 psig Saturated Steam.
 Vacuum Service to 29 inches Hg.
 MSS SP-110 compliant.



FEATURES

- Investment cast components
- Reinforced seats
- Mounting pad for easy actuator mounting
- Blow-out-proof stem design
- Adjustable packing gland
- Stainless Steel lever and nut

- Fire tested API 607, 6th edition (Requires "24" suffix)
- Meets NACE MR0175 (2000) & MR0103 (2012)
- CSA/CAN 3.16-M88 (2009) (Requires "01" suffix)
- NSF/ANSI 61 (2010) Section 8, Annex F & G
- NSF-372, Drinking Water System Components - Lead Content

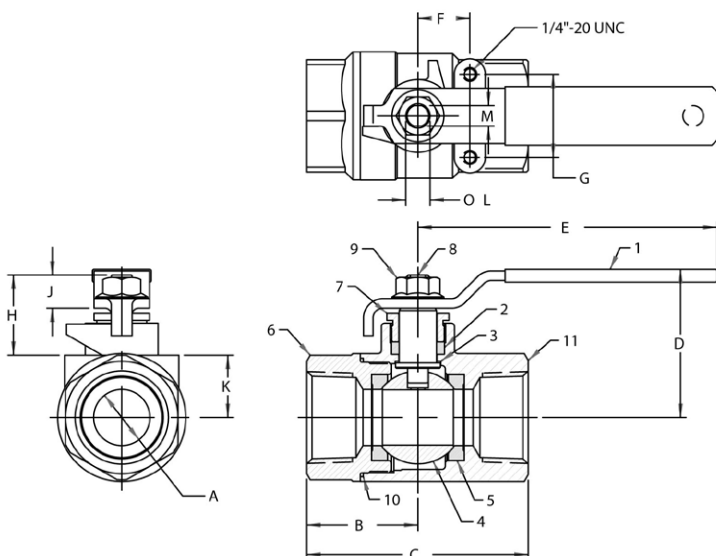

OPTIONS AVAILABLE: (More information in Section J)

(SUFFIX)	OPTION	SIZES
-01	Standard Configuration	All
-P -01-	BSPP (Parallel) Thread Connection	1/4" to 3"
-T -01-	BSPT (Tapered) Thread Connection	1/4" to 3"
-02-	Stem Grounded	1/4" to 3"
-04-	2.25" CS Stem Extension	1/4" to 3"
-07-	Steel Tee Handle	1/4" to 2"
-08-	90° Reversed Stem	1/4" to 3"
-14-	Side Vented Ball (Uni-Directional)	1/4" to 2"
-15-	Wheel Handle, Steel	1/4" to 2"
-16-	Chain Lever - Vertical	3/4" to 2"
-19-	Lock Plate	1/4" to 2"
-21-	UHMWPE Trim (Non-PTFE)	1/4" to 3"
-24-	Graphite Packing	1/4" to 3"
-27-	SS Latch-Lock Lever & Nut	1/4" to 3"
-30-	Cam-Lock and Grounded	1/4" to 2"
-32-	SS Tee Handle & Nut	1/4" to 2"
-35-	PTFE Trim	1/4" to 3"
-39-	SS Hi-Rise Locking Wheel Handle, SS Nut	1/4" to 2"
-40-	Cyl-Loc and Grounded	1/4" to 2"
-44-	Seal Welded	1/4" to 2"
-45-	Less Lever & Nut	1/4" to 3"
-46-	Latch Lock Lever - Lock in Closed Position Only	1/4" to 3"
-47-	SS Latch Lock Oval Handle	1/4" to 2"
-48-	SS Oval Handle (No Latch) & Nut	1/4" to 2"
-49-	No Lubrication. Assembled Dry.	1/4" to 3"
-50-	2.25" CS Locking Stem Extension	1/4" to 3"
-57-	Oxygen Cleaned	1/4" to 3"
-58-	Chain Lever - Horizontal	3/4" to 2"
-60-	Static Grounded Ball & Stem	1/4" to 3"
-64-	250# Steam Trim	1/4" to 3"

STANDARD MATERIAL LIST

PART	MATERIAL	
1	Lever and grip	304 SS w/vinyl
2	Stem packing	MPTFE
3	Stem bearing	RPTFE
4	Ball	A276-316 Stainless Steel
5	Seat (2)	RPTFE
6	Retainer	A351-CF8M Stainless Steel
7	Gland nut	A276-316 Stainless Steel
8	Stem	A276-316 Stainless Steel
9	Lever nut	18-8 Stainless Steel
10	Body seal	PTFE
11	Body	A351-CF8M Stainless Steel

PRODUCT NUMBER	SIZE	A	B	C	D	E	F	G	H	J	K	L	M	WT.
76-106-01	1.25"	1.00	2.00	4.00	2.68	5.40	0.94	1.50	1.50	0.60	1.12	0.625	0.377	3.10
76-107-01	1.5"	1.25	2.17	4.34	3.25	7.75	0.94	1.50	1.50	0.60	1.28	0.625	0.377	4.20
76-108-01	2"	1.50	2.69	5.43	3.24	7.75	0.94	1.50	1.46	0.60	1.50	0.625	0.377	6.10

FOR PRESSURE/TEMPERATURE RATINGS, REFER TO PAGE M-13, GRAPH NO. 12

