



# Trinity Lx150 (ASME) High Efficiency Gas Condensing Boiler

## Submittal Sheet

Section 1 - Specifications  
Section 2 - Dimensions  
Section 3 - Electrical

Project Name: \_\_\_\_\_ Date: \_\_\_\_\_  
 Location: \_\_\_\_\_  
 Engineer: \_\_\_\_\_  
 Contractor: \_\_\_\_\_ Rep: \_\_\_\_\_

### 1 SPECIFICATIONS

#### General Specifications

- ▶ Product Features
  - Certified to ANSI Z21.13 / CSA 4.9 Gas-fired Boiler Standard
  - ASME “H” stamped boiler, designed and constructed in compliance with the ASME Boiler and Pressure Vessel Code Section IV
  - SA-249 TP316L Stainless Steel Heat Exchanger
  - Maximum operating pressure 145 psi [1000 kPa]
  - Field conversion from Natural Gas (factory) to Propane
  - Modulating burner, 6:1 turndown
  - Direct Spark Ignition
  - Wall or floor mounting
  - Zero clearance to combustibles
- ▶ Optional sidewall vent kit (NTI part # 82666 & 84357)
- ▶ Factory Supplied Items (cont'd)
  - 1 – 500ml bottle Fernox FI Protector
  - 10K outdoor sensor (system sensor optional)
  - 30PSI ASME Relief Valve
  - 60PSI Pressure Gauge
- ▶ Control Features
  - Integral microprocessor safety control
  - 2 central heat inputs (high & low temperature)
  - Domestic Hot Water Priority
  - Outdoor reset
  - Warm weather shutdown
  - Lead-Lag up to 8 Lx series boilers
  - Integrated Modbus RTU for connection to BMS gateways

Water Connections NPT, in.	Gas Connection NPT, in.	Vent/Air-Intake Pipe Diameter in. [mm]	Vent/Air-Intake Max. Length, NG/LP ft. [m]	Approx. Weight with Water lb. [kg]
1 (Female)	½ (Female)	3 [76]	105 / 50 [32 / 15.2]	100 [45.3]

#### Heating Specifications

Input		Heating Capacity BTU/hr [kW]	AFUE %	Net I=B=R Rating BTU/hr [kW]
Min BTU/hr [kW]	Max BTU/hr [kW]			
25,000 [7.3]	150,000 [44.0]	136,000 [53.3]	93.5	118,000 [34.8]

#### Performance Specifications

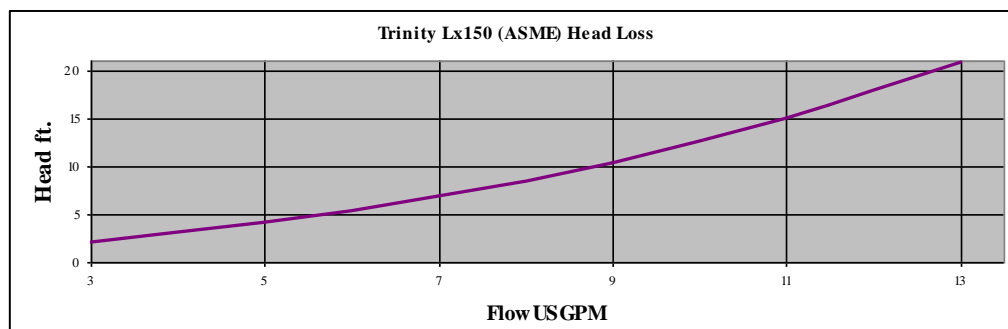

NY Thermal Inc.

65 Drury Cove Road, Saint John, NB E2H 2Z8 Canada

Technical Service: 1-800-688-2575 Fax: 1-506-432-1135 Web: <http://www.nythermal.com>

NY Thermal Inc. reserves the right to change these specifications without notice



# Trinity Lx150 (ASME) High Efficiency Gas Condensing Boiler

## Submittal Sheet

### 2 DIMENSIONS

#### Product Dimensions – in. [mm]

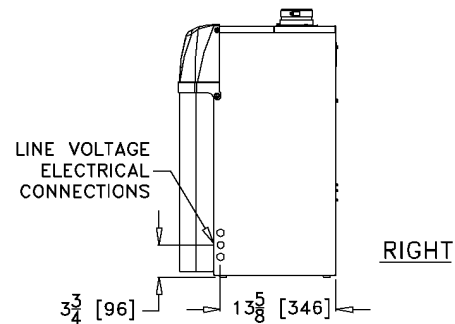
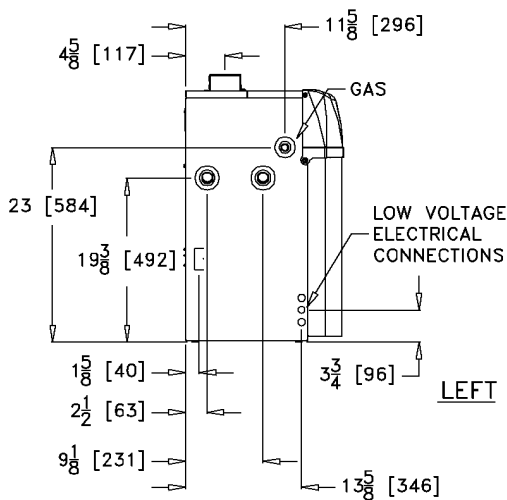
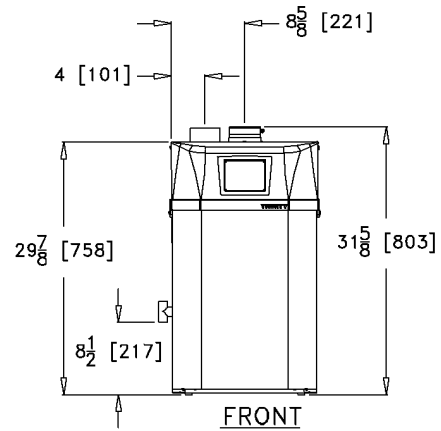
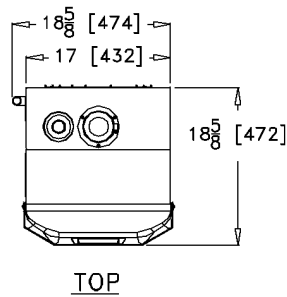

#### Recommended Clearances – in. [mm]

Top	Front	Left	Right	Back	Bottom
24 [610]	24 [610]	24 [610]	4 [102]	0	0



NY Thermal Inc.

65 Drury Cove Road, Saint John, NB E2H 2Z8 Canada

Technical Service: 1-800-688-2575 Fax: 1-506-432-1135 Web: <http://www.nythermal.com>

NY Thermal Inc. reserves the right to change these specifications without notice



# Trinity Lx150 (ASME) High Efficiency Gas Condensing Boiler

## Submittal Sheet

### 3 ELECTRICAL

#### Simplified Wiring Diagrams

##### Line Voltage Electrical:

- ▶ 120VAC / 60 Hz / 1 Phase / 12 Amp
- ▶ Barrier Strip for field wiring terminations
- ▶ 3 Pump outputs
  - Indirect Domestic Hot Water (Pump A)
  - Boiler (Pump B)
  - Central Heat (Pump C)

Note: Pumps are field supplied.

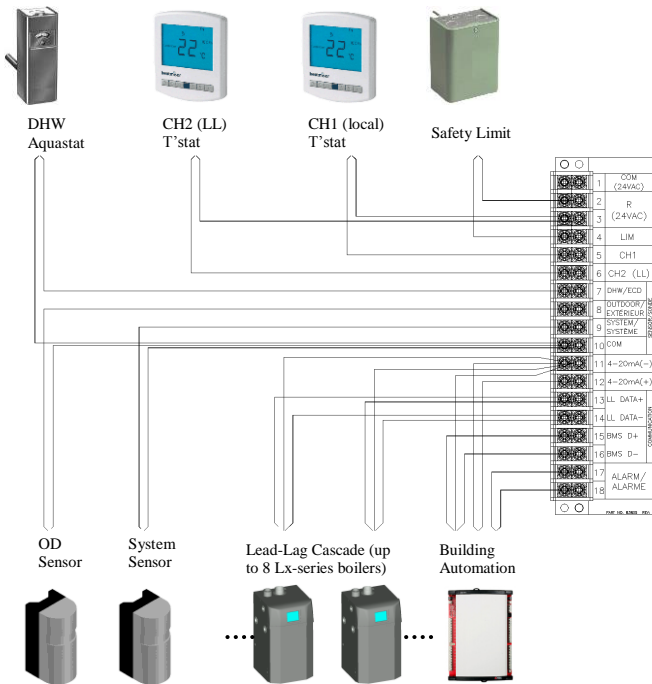
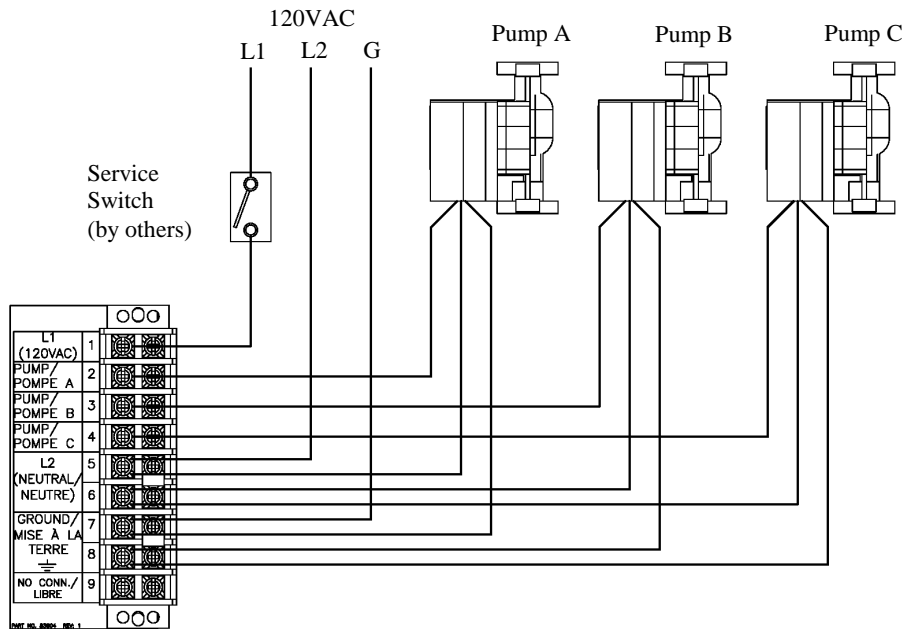

##### Low Voltage Electrical:

- ▶ Barrier Strip for field wiring terminations
  - ▶ 120/24 VAC Transformer 40VA (factory supplied)
  - ▶ Inputs
    - CH1 thermostat (by others)
    - CH2 thermostat (by others)
    - Indirect DHW aquastat (by others) or DHW Tank sensor (factory option)
    - External Limit (by others)
    - Outdoor sensor (factory supplied)
    - System sensor (factory option)
    - 4-20mA external modulating control (by others)
  - ▶ Outputs
    - Alarm dry contact (24VAC 0.63A max.)
  - ▶ EIA-485 Modbus communications for Lead-Lag
  - ▶ EIA-485 Modbus to BMS gateways (not shown).
- Optional available gateways:
- BACnet/N2- NTI part # 84946
  - LonWorks- NTI part # 84947



NY Thermal Inc.

65 Drury Cove Road, Saint John, NB E2H 2Z8 Canada

Technical Service: 1-800-688-2575 Fax: 1-506-432-1135 Web: <http://www.nythermal.com>

NY Thermal Inc. reserves the right to change these specifications without notice