

# ELKAY® SPECIFICATIONS

## No Lead Two-Level Drinking Fountain Soft Sides® Wall Mount-Fully Exposed with Wall Plate Barrier-Free Access Model EDFP217C

### GENERAL

Two-level wall mounted drinking fountain constructed of #18 gauge, type 304, stainless steel polished to a lustrous satin finish.

Contoured basin minimizes splashing and has exclusive Flexi-Guard® safety bubbler to prevent accidental mouth injuries. Keyed in location to prevent rotation. Easy to operate, fully functional push-buttons are vandal-resistant. Vandal-resistant bottom cover plates included. Flow regulator provides constant stream from 20 to 105 psi water pressure.

**THIS DRINKING FOUNTAIN COMPLIES WITH THE REQUIREMENTS OF A.D.A. (AMERICANS WITH DISABILITIES ACT) WHEN PROPERLY INSTALLED. UNIT IS COMPLIANT IF INSTALLED IN AN ALCOVE AND IS ALSO COMPLIANT WHEN MOUNTED ON AN EXPOSED WALL IF A WING WALL IS LOCATED ON THE LEFT SIDE OR IF A 97258C APRON IS INSTALLED UNDER THE UPPER UNIT.**

### NO LEAD DESIGN

**THIS DRINKING FOUNTAIN COMPLIES WITH THE LEAD-FREE DEFINITION IN THE SAFE DRINKING WATER ACT OF 1986 AND LEAD CONTAMINATION CONTROL ACT OF 1988.**

Elkay Drinking Fountains are manufactured with a waterway system utilizing copper components and completely lead-free material. These waterways have no lead because all leaded materials, such as leaded brass, have been removed.

This fountain is certified by WQA to lead-free compliance including NSF/ANSI 61 and 372.

### CONSTRUCTION

**EDFP217C** furnished complete with Flexi-Guard®, fully assembled front push-buttons, flow regulator (20 to 105 psi), and drain, trap assemblies and vandal-resistant bottom cover plates.

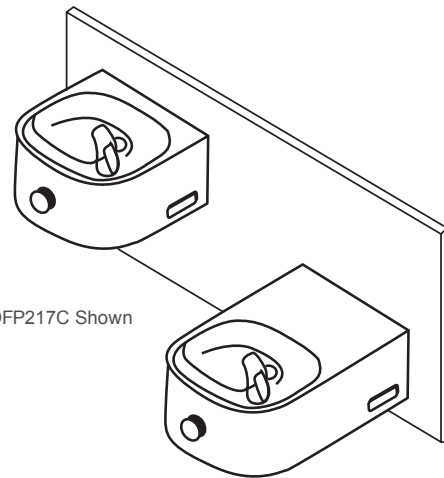

Model EDFP217C Shown

### ALSO AVAILABLE

**Model EDFPVR217C:** Includes vandal-resistant bubblers. Heavy-duty, one-piece construction, chrome plated brass.

**Model EDFP217FC:** Plumbed for use with glass filler. Long fountain arm only. LK1110 or LK1114 sold separate.

**Model EDFP217FPK:** Freeze-resistant model with boxes (see separate specification sheet).

### ACCESSORIES

**MP20** Surface mounting plate.

**MPW200** In-wall carrier mounting plate.

**ML100** Support columns for MPW200.

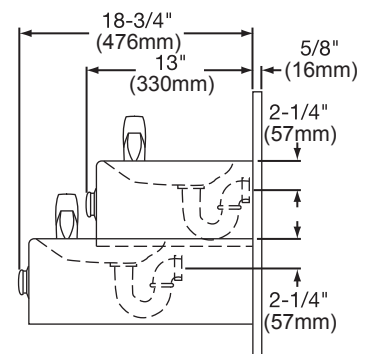
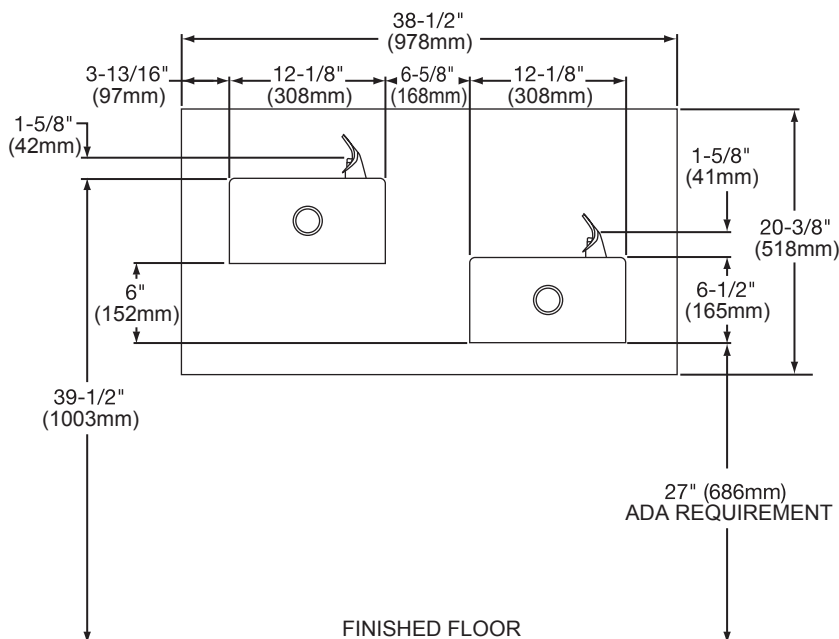

In keeping with our policy of continuing product improvement, Elkay reserves the right to change product specifications without notice. Please visit [elkayusa.com](http://elkayusa.com) for most current version of the product specification sheet.

This specification describes an Elkay product with design, quality and functional benefits to the user. When making a comparison of other producers' offerings, be certain these features are not overlooked.

**Elkay**

[elkayusa.com](http://elkayusa.com)

2222 Camden Court  
Oak Brook, IL 60523

Printed in U.S.A.  
©2012 Elkay

(Rev. 9/12) 14-27G

**No Lead Two-Level Drinking Fountain Soft Sides®  
Wall Mount-Fully Exposed with Wall Plate  
Barrier-Free Access Model EDP217C**

**ELKAY®  
ROUGH-IN DIMENSIONS**

**INSTALLER NOTE**

THIS DRINKING FOUNTAIN IS FURNISHED WITH A BUBBLER AND VALVE INCLUDING ALL CONNECTING FITTINGS WHICH ARE MANUFACTURED OF COMPLETELY LEAD FREE MATERIAL. SHUT OFF VALVE (NOT FURNISHED) TO ACCEPT 3/8" O.D. UNPLATED COPPER TUBE.

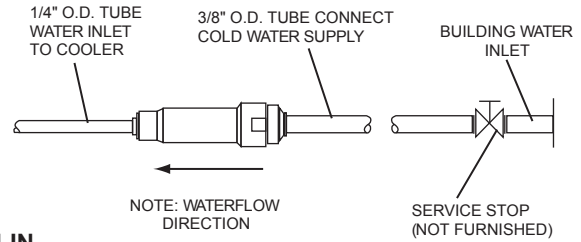

**OPERATION OF QUICK CONNECT FITTINGS**

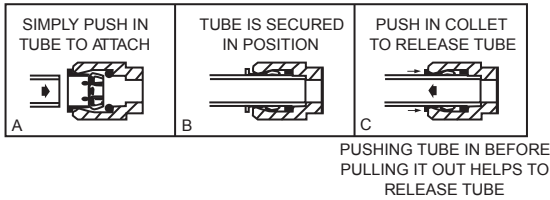

**WALL ROUGH-IN**

NOTE: When using MP20 Surface Mounting Plate, remove the wall hanger and back panel channels. See separate specification sheet for details on MP20 Surface Mounting Plate.

NOTE: Reinforce the wall in the shaded areas to support up to 300 lbs. static load.

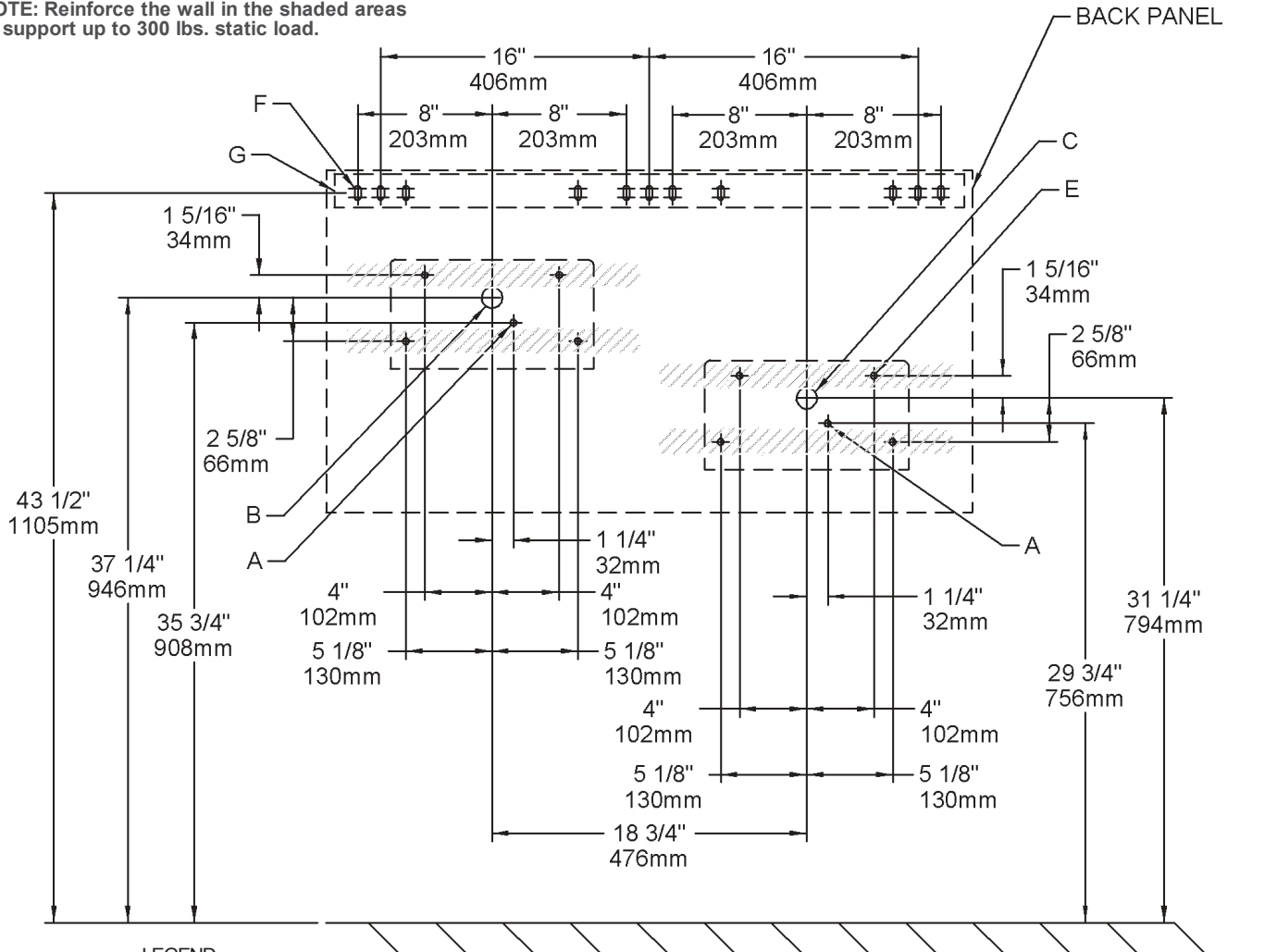

**LEGEND**

- A = RECOMMENDED WATER SUPPLY LOCATION 3/8 O.D. UNPLATED COPPER TUBE CONNECT STUBBED 1-1/2" (38mm) FROM WALL SHUT OFF BY OTHERS
- B = RECOMMENDED LOCATION FOR WASTE OUTLET 1-1/4" O.D. DRAIN STUBBED 1-1/2" (35mm) FROM THE WALL
- C = RECOMMENDED LOCATION FOR WASTE OUTLET 1-1/4" O.D. DRAIN STUBBED 6-3/4" (168mm) FROM THE WALL

- D = 1-1/4" TRAP FURNISHED
- E = 3/8" (10mm) DIA. HOLES FOR SECURING FOUNTAIN TO WALL
- F = 3/8" (10mm) DIA. SLOTS FOR MOUNTING HANGER TO WALL
- G = WALL HANGER FURNISHED LOOSE