



# Z-1000-P DEEP SEAL TRAP

SPECIFICATION SHEET

TAG \_\_\_\_\_

Dimensional Data (inches and [ mm ]) are Subject to Manufacturing Tolerances and Change Without Notice

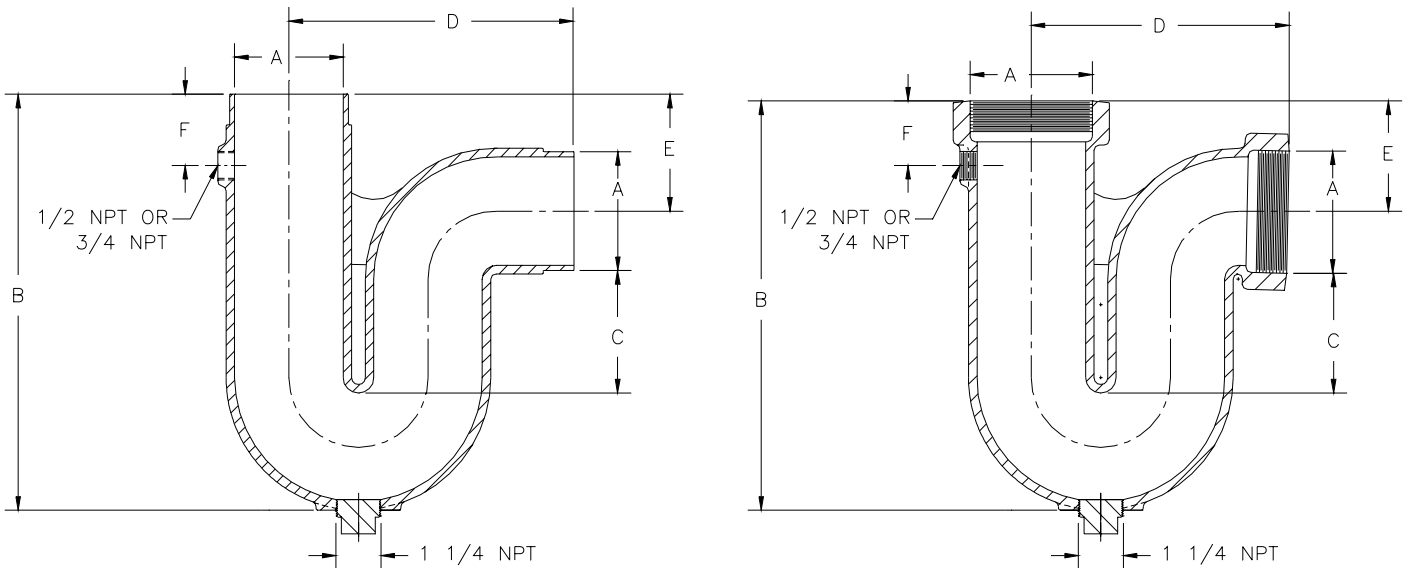

Dimensions In Inches						Approx. Wt. Lbs. [kg]
A Pipe Size	B	C	D	E	F	
Threaded						
2 [50]	9 1/2 [241]	4 [102]	5 7/8 [149]	1 3/4 [44]	1 5/8 [41]	8 [4]
3 [75]	13 [330]	5 [127]	7 1/2 [190]	3 [76]	2 1/8 [54]	17 [8]
4 [100]	15 [381]		9 1/2 [241]	4 [102]	2 3/8 [60]	32 [14]
No-Hub						
2 [50]	10 1/2 [267]	4 [102]	6 1/2 [165]	2 3/4 [70]	2 5/8 [67]	8 [4]
3 [75]	13 1/2 [343]	5 [127]	8 [203]	3 1/2 [89]	2 5/8 [67]	17 [8]
4 [100]	15 1/4 [387]		9 1/2 [241]	4 1/4 [108]	2 5/8 [67]	32 [14]

**ENGINEERING SPECIFICATION:** ZURN Z-1000-P Deep Seal Trap, Dura-Coated cast iron body with trap primer connection and bronze bottom cleanout plug.

**CONNECTIONS** (Check/specify appropriate options)

**PIPE SIZE**

2, 3, 4 [50, 75, 100]  
2, 3, 4 [50, 75, 100]

(Specify size/type) **CONNECTION**

\_\_\_\_ IP Threaded  
\_\_\_\_ NH No-Hub

**PREFIXES**

\_\_\_\_ Z- D.C.C.I. Body\*

**SUFFIXES**

\_\_\_\_ -G Galvanized Cast Iron  
\_\_\_\_ -FL Flushing Connection

\*REGULARLY FURNISHED UNLESS OTHERWISE SPECIFIED

REV.	DATE: 2/17/00	C.N. NO. 84378
DWG. NO. 63845	PRODUCT NO. Z-1000-P	