

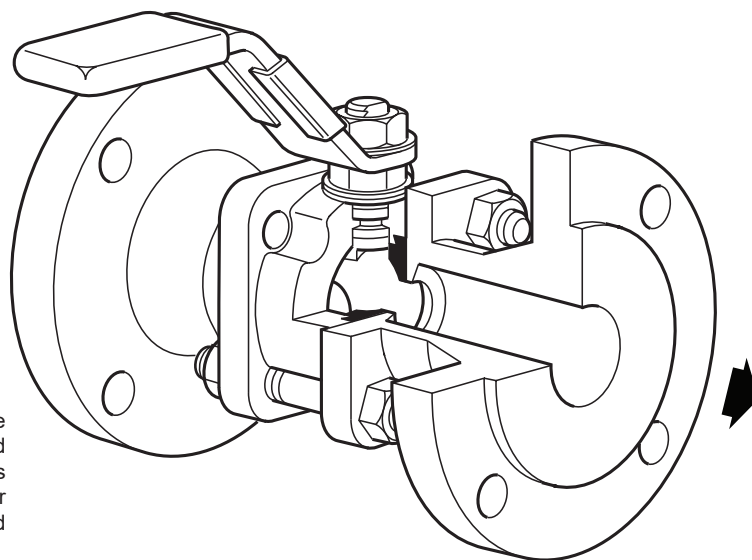

M10S Ball Valve DN $\frac{1}{4}$ " to DN $2\frac{1}{2}$ "



Description

The M10S three-piece body ball valve has been designed for use as an isolating valve, not a control valve, and can be serviced without removal from the pipeline (screwed and welded versions only). It can be used with the majority of industrial fluids for services ranging from vacuum to the higher temperatures and pressures.

Available types

M10S2_ _ Zinc plated carbon steel body, PDR 0.8 seats.

M10S3_ _ Stainless steel body, PDR 0.8 seats.

M10S4_ _ Complete stainless steel, PDR 0.8 seats.

Note: The nomenclature will be followed with either **FB** (full bore) or **RB** (reduced bore).

Standards

This product fully complies with the requirements of the Pressure Equipment Directive (PED) and carries the  mark when so required.

Certification

This product is available with certification to EN 10204 3.1.

Note: All certification/inspection requirements must be stated at the time of order placement.

Sizes and pipe connections

Full bore

$\frac{1}{4}$ ", $\frac{3}{8}$ ", $\frac{1}{2}$ ", $\frac{3}{4}$ ", 1", $1\frac{1}{4}$ ", $1\frac{1}{2}$ " and 2"

Screwed and welded

BSP, BSPT, API/NPT, BW, SW

Flanged

DN15 to DN50

ASME Class 150, ASME Class 300, and EN 1092 PN40.

Reduced bore

$\frac{1}{4}$ ", $\frac{3}{8}$ ", $\frac{1}{2}$ ", $\frac{3}{4}$ ", 1", $1\frac{1}{4}$ ", $1\frac{1}{2}$ ", 2" and $2\frac{1}{2}$ "

Screwed and welded

BSP, BSPT, API/NPT, BW, SW

Flanged

DN15 to DN65

ASME Class 150, ASME Class 300, and EN 1092 PN40.

Technical data

Flow characteristic	Modified linear
Port	Full and reduced port versions
Leakage test procedure to ISO 5208 (Rate A)/EN 12266-1 (Rate A)	
Antistatic device	Complies with ISO 7121 and BS 5351

Pressure/temperature limits

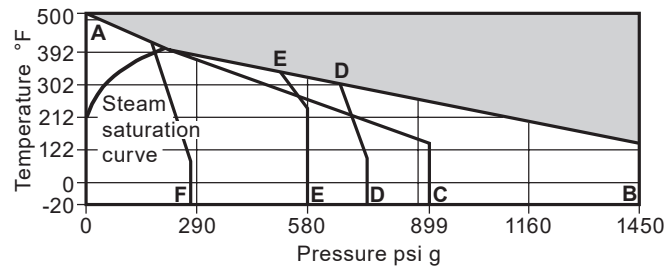

The product **must not** be used in this region.

A - B Screwed, BW and SW ¼" - 1½" FB, RB and 2" RB.

A - C Screwed, BW and SW 2" FB and 2½" RB only.

A - D Flanged ASME (ANSI) 300.

A - E Flanged EN 1092 PN40.

A - E Flanged ASME (ANSI) 150.

Note 1: On the 2" FB and 2½" RB a PTFE gasket is fitted between the body and cap.

Note 2: The flange standard may restrict the maximum operating pressure. Please check with Spirax Sarco.

Note 3: In gases applications, the maximum operating pressure is restricted to 580 psi g.

Body design conditions	ANSI 600
PMA Maximum allowable pressure	1450 psi g @ 140 °F
TMA Maximum allowable temperature	500 °F @ 0 psi g
Minimum allowable temperature	-20 °F
PMO Maximum operating pressure for saturated steam service	254 psi g
TMO Maximum operating temperature	500 °F @ 0 psi g
Minimum operating temperature	-20 °F
Note: For lower operating temperatures consult Spirax Sarco	
ΔPMX Maximum differential pressure is limited to the PMO	
Designed for a maximum cold hydraulic test pressure of:	2175 psi g

Materials

Please note:
Screwed, butt weld and socket weld M10V ball valves have bolts and nuts.
Flanged M10V ball valves have studs and nuts.

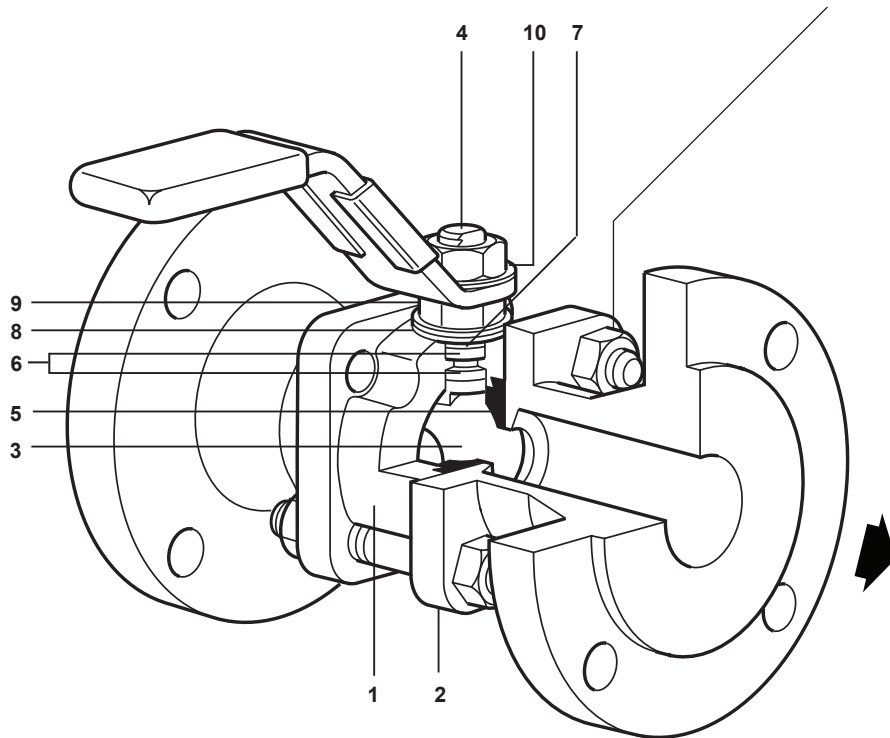

No.	Part	Material	
1	Body	M10S2	Zinc plated carbon steel ASTM A105
		M10S3 M10S4	Stainless steel ASTM A 182 F 316L
		M10S2	Zinc plated carbon steel ASTM A105
2	Cap	M10S3 M10S4	Stainless steel ASTM A 182 F 316L
		M10S2	Zinc plated carbon steel ASTM A105
		M10S3 M10S4	Stainless steel ASTM A 182 F 316L
3	Ball	Stainless steel	AISI 316
4	Stem	Stainless steel	AISI 316
5	Seat	Carbon/graphite reinforced PTFE	PDR 0.8
6	Stem seal	Reinforced PTFE antistatic	
7	Separator	M10S2 M10S3	Zinc plated carbon steel SAE 1010
		M10S4	Stainless steel AISI 316
		M10S2	Zinc plated carbon steel SAE 12L14
8	Spring washers	Stainless steel	AISI 301
9	Nut	M10S3 M10S4	Stainless steel AISI 304
		M10S2	Zinc plated carbon steel SAE 12L14
		M10S4	Stainless steel AISI 304
10	Name-plate (DN)	Stainless steel	AISI 430

Materials continued on the next page

Please note:
Screwed, butt weld and socket weld M10V ball valves have bolts and nuts.
Flanged M10V ball valves have studs and nuts.

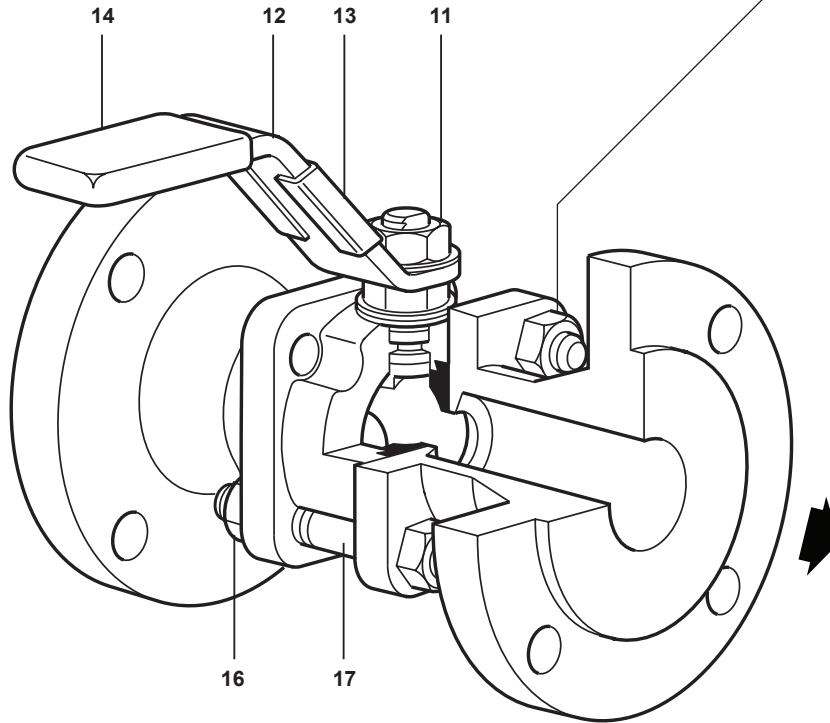

No.	Part	Material		
11	Stem nut	M10S2 M10S3	Zinc plated carbon steel	SAE 12L14
		M10S4	Stainless steel	AISI 304
		M10S2 M10S3	Zinc plated carbon steel	SAE 1010
12	Lever	M10S4	Stainless steel	AISI 316
		13	Name-plate	Stainless steel
14	Grip	Vinyl		
15 *	Bolts	M10S2 M10S3	Zinc plated carbon steel	A 193 B7
		M10S4	Stainless steel	AISI 304
		16	Nuts	M10S2 M10S3
M10S4	Stainless steel			AISI 304
17	Studs	M10S2 M10S3	Zinc plated carbon steel	Grade 5
		M10S4	Stainless steel	AISI 304

* **Note:** Item 15 not shown - Screwed, butt weld and socket weld versions only.

Dimensions (approximate) in inches

Reduced bore

Size	A	A1	A2	A3	A4	B	B1	C	C1	D	D1	D2	D3	E
¼"	2.2	2.1	-	-	-	4.7	-	2.4	-	0.9	-	-	-	0.4
⅜"	2.2	2.1	-	-	-	4.7	-	2.4	-	0.9	-	-	-	0.4
½"	2.5	2.1	4.3	5.1	5.5	4.7	4.7	2.4	3.0	0.9	3.5	3.7	3.7	0.4
¾"	2.7	2.4	4.6	5.9	6.0	4.7	4.7	2.5	4.0	1.0	3.9	4.1	4.6	0.6
1"	3.4	3.3	5.0	6.3	6.5	6.2	6.2	3.6	3.6	1.2	4.3	4.5	4.9	0.8
1¼"	3.9	3.7	5.5	7.1	7.0	6.2	6.2	3.7	3.7	1.5	4.6	5.5	5.2	0.9
1½"	4.3	4.0	6.5	7.9	7.5	7.1	7.1	4.3	4.3	1.6	5.0	5.9	6.1	1.2
2"	4.9	4.7	7.0	9.0	8.5	7.1	7.1	4.5	4.5	1.9	6.0	6.5	6.5	1.5
2½"	5.9	5.9	7.5	-	9.5	9.6	-	5.2	5.2	2.2	-	-	7.5	2.0

Full bore

Size	A	A1	A2	A3	A4	B	B1	C	C1	D	D1	D2	D3	E
¼"	2.4	2.0	-	-	-	4.7	-	2.4	-	0.9	-	-	-	0.4
⅜"	2.4	2.4	-	-	-	4.7	-	2.4	-	0.9	-	-	-	0.4
½"	2.7	2.7	-	5.1	5.5	4.7	4.7	2.5	-	1.0	-	3.7	3.7	0.5
¾"	3.4	3.4	-	5.9	6.0	6.2	6.2	3.6	3.6	1.2	-	4.1	4.6	0.8
1"	3.8	3.8	-	6.3	6.5	6.2	6.2	3.7	3.7	1.5	-	4.5	4.9	1.0
1¼"	4.2	4.2	-	7.1	7.0	7.1	7.1	4.3	4.3	1.6	-	5.5	5.2	1.2
1½"	4.9	4.9	-	7.9	7.5	7.1	7.1	4.5	4.5	1.9	-	5.9	6.1	1.5
2"	6.0	6.0	-	9.0	8.5	9.6	9.6	5.2	5.2	2.2	-	6.5	6.5	2.0

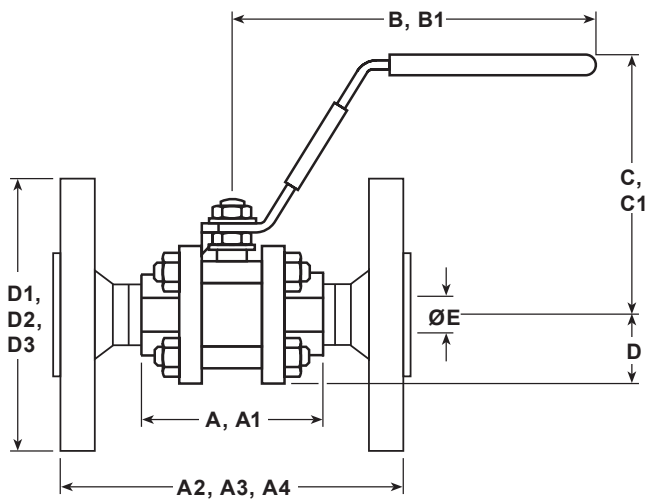

- A:** Screwed and Butt weld
- A1:** Socket weld
- A2:** Flanged ASME 150
- A3:** Flanged PN40
- A4:** Flanged ASME 300
- B:** Screwed, Butt weld and Socket weld
- B1:** Flanged ASME 150, PN40
- C:** Screwed, Butt weld and Socket weld
- C1:** Flanged ASME 150, Flanged PN40
- D:** Screwed, Butt weld and Socket weld
- D1:** Flanged ASME 150
- D2:** Flanged PN40
- D3:** Flanged ASME 300

Weights (approximate) in lbs

Size	Reduced bore				Full bore		
	Scrd/BW/SW	PN40	ASME 150	ASME 300	Scrd/BW/SW	PN40	ASME 300
1/4"	1.3	-	-	-	1.3	-	-
3/8"	1.3	-	-	-	1.3	-	-
1/2"	1.3	4,9	3.6	4.8	1.5	5.1	5.5
3/4"	1.5	6,4	4.8	6.3	2.8	7.7	9.2
1"	2.8	8,6	7.5	9.9	3.9	9.7	11.2
1 1/4"	3.9	11,9	9.8	15.4	5.5	13.7	16.5
1 1/2"	5.5	14,3	12.8	18.4	7.7	16.5	22.0
2"	7.7	19,4	19.8	24.7	15.2	26.9	29.5
2 1/2"	15.2	-	-	38.6	-	-	-

C_v values

Size	1/4"	3/8"	1/2"	3/4"	1"	1 1/4"	1 1/2"	2"	2 1/2"
Reduced bore	3	8	7	12	31	57	81	119	194
Full bore	3	8	20	42	67	102	176	240	0

For conversion:

$$C_v \text{ (UK)} = K_v \times 0.963$$

$$C_v \text{ (US)} = K_v \times 1.156$$

Operating torque (ft/lbf)

Size	1/4"	3/8"	1/2"	3/4"	1"	1 1/4"	1 1/2"	2"	2 1/2"
Reduced bore	1.5	1.5	1.5	3	10	15.5	23	29.5	33.5
Full bore	1.5	1.5	3	10	15.5	23	29.5	33	-

The indicated torque values are for valves frequently operated, that are submitted to a maximum differential pressure of 900 psi g. Valves that are subject to long static periods, may require greater break-out torque.

Safety information, installation and maintenance

For full details see the Installation and Maintenance Instructions supplied with the product.

Welding

Only the models that have connections designed for welding (SW, BW, Imperial Tube connections) should be welded. Valves with SW or BW welding connections must be disassembled before welding onto the pipeline, the ends should be welded separately and the valve should be reassembled when the ends are cool. Carbon steel valves with threaded (BSPT, BSP, NPT) or flanged connections must not be welded to avoid damages to the valve and/or injury to personnel.

How to order example:

1 off Spirax Sarco ½" screwed BSP M10S2FB ball valve.

Optional extras:

- Self-venting ball.
- Extended stems 50 mm (2") and 100 mm (4") to allow full insulation.
- Lockable handle.
- Fully degreased under request (ie: Oxygen application).

Spare parts

The spare parts available are shown in solid outline. Parts drawn in a grey line are not supplied as spares.

Available spares

Seat and stem seal set	5, 6
------------------------	------

How to order spares

Always order spares by using the description given in the column headed 'Available spares' and state the size and type of ball valve.

Example: 1 - Seat and stem seal set for a ½" M10S2FB ball valve.

