



Phoenix Light Duty Commercial Gas-Fired Water Heater Submittal Sheet

JOB NAME:

LOCATION:

ARCH./ENGR.:

WHOLESALER:

MECH. CONTRACTOR:

MODEL NUMBER:

BTU/HR INPUT LOW – HIGH FIRE:

TYPE OF GAS:

NOTES:

High Efficiency Heat Exchanger

- Copper Nickel heat exchanger
- Gasketless heat exchanger design

Combustion System

- Modulating burner with up to 3 to 1 turndown
- High-Grade Inconel premix burner
- Spark ignition
- Fires on Natural or LP Gas
- Flame monitoring
- Flame stabilization monitoring – Automatic adjustment of firing rate to stabilize flame signal

Integrated Control System

- Digital operating control with LCD display three character for temperature and system monitor - LCD indicators for appliance faults
- Outdoor reset
- 120 volt 5 amp electrical connection for condensate pump
- Outdoor sensor input
- High Limit protection monitoring
- Flue sensor monitoring

Stainless Steel Tank

- Quality tank construction of 316 L stainless steel
- Auxiliary Port for recirculation line and higher operating efficiency
- Inlet and outlet plumbing connections off the top
- Installed Temperature and Pressure relief valve
- Full port brass drain valve

Additional Features

- Vents in 2” PVC - CPVC - stainless steel – ULC S636 flexible polypropylene vent liner (chimney lining only)
- Vents up to 150 combined equivalent feet
- Manual reset high limit
- Included High Output Cold Water Dip Tube
- NSF Listed
- Low NOx emissions – SCAQMD Certified
- Lead Free Compliant, as required by the Safe Drinking Water Act, Section 1417
- Installed Anode Rod to further prevent corrosion

Optional Equipment

- Outdoor Sensor (Part # 7250P-319)
- 2” PVC Concentric Vent Kit (Part # KGAVT0501CVT)
- 3” PVC Concentric Vent Kit (Part # KGAVT0601CVT)
- 2” Stainless Steel Outside Termination Vent Kit (Part # V500)
- 3” Stainless Steel Outside Termination Vent Kit (Part # V1000)

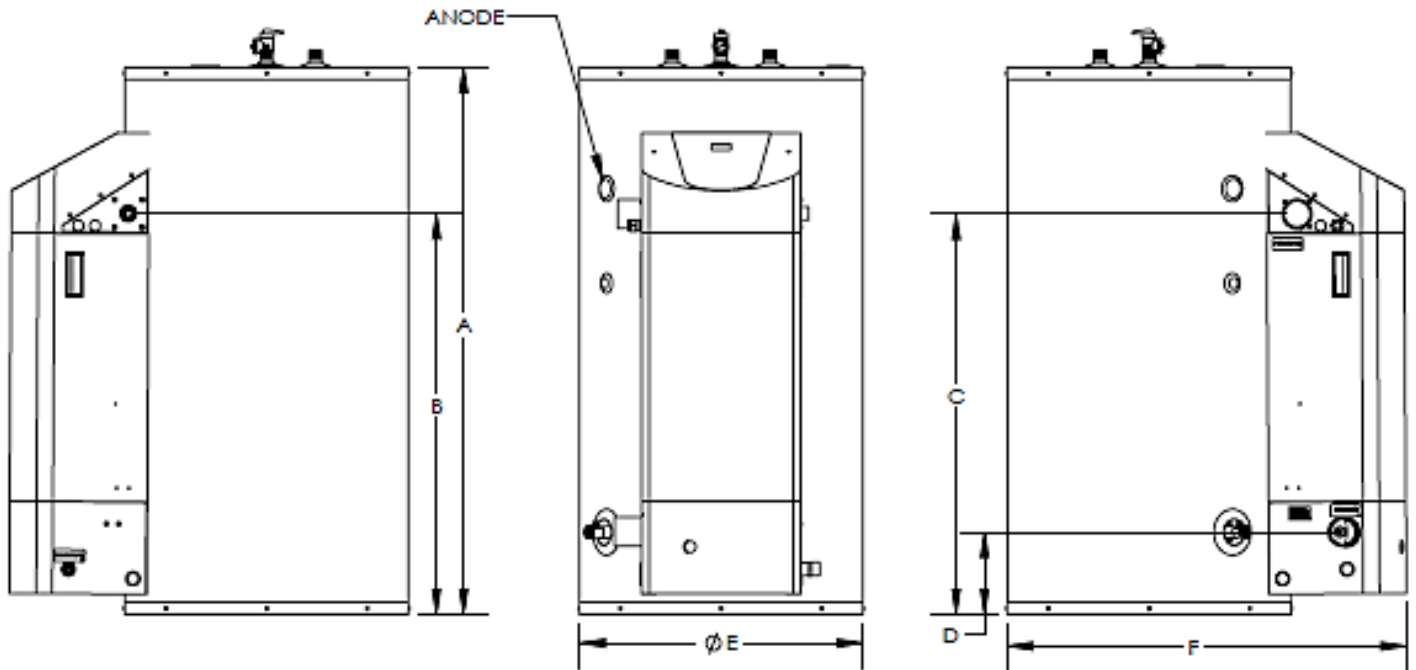
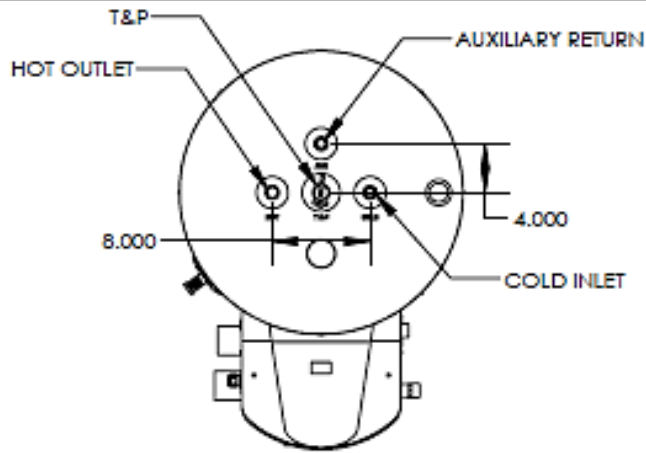

MODEL #	GALLONS	A	B	C	D	E	F
PH76-50	45	44-3/4"	33"	33"	6-3/4"	23"	32-1/2"
PH76-60	55	52-5/8"					
PH76-80	75	69"					

LP-441-D
06/29/21

MODEL #	INPUT MODULATION	AIR INTAKE/EXHAUST VENT SIZE	INLET/OUTLET SIZE	AUXILIARY CONN.	GAS LINE CONN.	SYSTEM RELIEF PIPE SIZE	SHIPPING WEIGHT (LBS)	MAX. TEMPERATURE LIMIT
PH76-50	25,000 -76,000	2"	3/4"	3/4"	1/2"	3/4"	155	160*
PH76-60							170	
PH76-80							195	

MODEL NUMBER MAY HAVE A SUFFIX DESIGNATION OF "LP" FOR PROPANE GAS
ALL DIMENSIONS ARE APPROXIMATE

PERFORMANCE SPECIFICATIONS FOR PHOENIX LIGHT DUTY MODELS

BTUH	Temperature Rise in Degrees Fahrenheit											
	(°F)	40	50	60	70	80	90	100	110	120	130	140
	(°C)	22	28	33	39	44	50	56	61	67	72	78
76,000	GPH	231	187	158	135	119	107	97	86	79	73	69
	LPH	874	708	598	511	450	405	367	326	299	276	261

Recovery on rating plate is based at 97% thermal efficiency at 70° Fahrenheit rise, as required by ANSI