

# BIS RapidRail® Wall Plate

fixing to wall

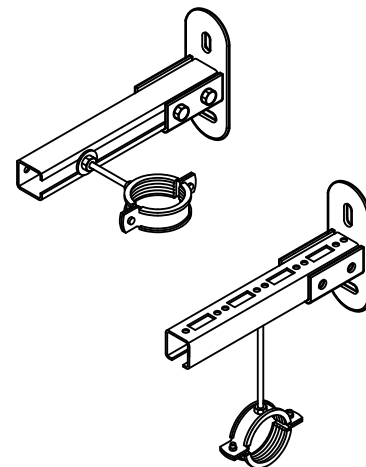

## Features and benefits

- U-profile welded on wall plate
- for floor or wall mounting
- rail can be fixed with slot downwards or sideways
- Part No. 661 3 200: suitable for WM0, 1, 15, 2, 30
- slots at 90° to each other to simplify fixing
- CO<sub>2</sub> welded
- with pre-assembled BIS RapidRail® Slide nut(s) for quick installation ... retains assembly in place before final tightening
- material: metal parts made of steel 1.0332; spring(s) made of POM (polyoxymethylene), green
- zinc plated

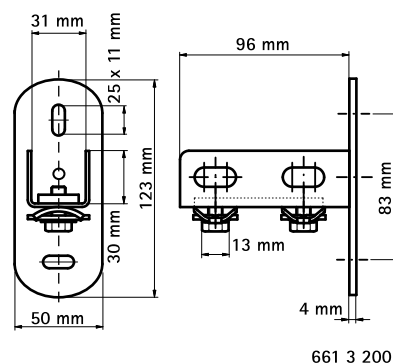

Part No.	For Rail	T (Nm)	Pack 1
661 3 200	WM0, 15, 2, 30	15	25

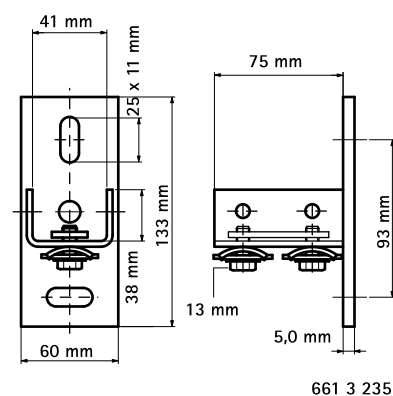

**Complementary**  
BIS RapidRail® Fixing Rail