

Job Name:

System Reference:

Date:

Indoor Unit:
SLZ-KF18NAOutdoor Unit:
SUZ-KA18NA2**INDOOR UNIT FEATURES**

- Ceiling-recessed cassette (24"x24") ductless heat pump
- Install SLZ in a drywalled ceiling (with an access panel for servicing) or in a 2'x2' drop ceiling
- Wide airflow pattern for excellent air distribution
- Fresh air intake provided in the main body
- Built-in drain condensate lift mechanism (lifts to 33")
- Multiple control options available:
 - kumo cloud® smart device app for remote access
 - Third-party interface options
 - Wired or wireless controllers
- Long-life air filter included
- Individual vane control

OUTDOOR UNIT FEATURES

- Variable speed INVERTER-driven compressor
- Innovative Joint Lap DC Motor leads to high efficiency and reliability
- Pulse Amplitude Modulation technology
- High-performance grooved piping for increased heat exchange efficiency

SPECIFICATIONS: SLZ-KF18NA & SUZ-KA18NA2

Cooling at 95°F ¹	Maximum Capacity	BTU/H	17,700
	Rated Capacity	BTU/H	17,700
	Minimum Capacity	BTU/H	6,100
	Maximum Power Input	W	1,410
	Rated Power Input	W	1,410
	Moisture Removal	Pints/h	4.7
	Sensible Heat Factor		0.71
	Power Factor (208/230V)	%	98
Cooling at 82°F	Maximum Capacity	BTU/H	18,100
	Rated Capacity	BTU/H	18,100
	Minimum Capacity	BTU/H	6,400
	Maximum Power Input	W	1,180
	Rated Power Input	W	1,180
Heating at 47°F ²	Maximum Capacity	BTU/H	20,900
	Rated Capacity	BTU/H	19,700
	Minimum Capacity	BTU/H	8,400
	Maximum Power Input	W	2,100
	Rated Power Input	W	1,850
	Power Factor	%	98
Heating at 17°F ³	Maximum Capacity	BTU/H	12,900
	Rated Capacity	BTU/H	12,900
	Maximum Power Input	W	1,410
	Rated Power Input	W	1,410
Heating at 5°F ⁴	Maximum Capacity	BTU/H	9,800
	Maximum Power Input	W	1,210
Heating at -4°F ⁵	Maximum Capacity	BTU/H	7,200
Efficiency	SEER		20.7
	EER ¹		12.5
	HSPF (IV)		11.6
	COP at 47°F ²		3.10
	COP at 17°F in Maximum Capacity ³		2.68
	COP at 5°F in Maximum Capacity ⁴		2.37
	ENERGY STAR [®] certified units (ENERGY STAR products are third-party certified by an EPA-recognized Certification Body.)		Yes
Electrical	Voltage, Phase, Frequency		208/230V, 1 phase, 60Hz
	Guaranteed Voltage Range	V AC	187-253
	Voltage: Indoor - Outdoor, S1-S2	V AC	208/230
	Voltage: Indoor - Outdoor, S2-S3	V DC	24
	Short-circuit Current Rating (SCCR)	kA	5
	Recommended Fuse/Breaker Size (Outdoor)	A	15
	Recommended Wire Size (Indoor - Outdoor)	AWG	14
Indoor Unit	MCA	A	0.54
	Fan Motor Full Load Amperage	A	0.43
	Fan Motor Output	W	50
	Airflow Rate at Cooling, Dry	CFM	475-420-300
	Airflow Rate at Cooling, Wet	CFM	429-378-270
	Airflow Rate at Heating, Dry	CFM	475-420-300
	Sound Pressure Level (Cooling)	dB(A)	43-40-32
	Sound Pressure Level (Heating)	dB(A)	43-40-32
	Drain Pipe Size	In. (mm)	1-1/4 (32)
	Condensate Lift Mechanism, Maximum Distance	In. (mm)	33 (850)

SPECIFICATIONS: SLZ-KF18NA & SUZ-KA18NA2

	Heat Exchanger Type		Plate fin coil
	External Finish Color		Munsell 1.0Y 9.2/0.2
	Unit Dimensions	W: In. (mm)	22-7/16 (570)
		D: In. (mm)	22-7/16 (570)
		H: In. (mm)	9-21/32 (245)
	Package Dimensions	W: In. (mm)	24-13/32 (620)
		D: In. (mm)	27-15/16 (710)
		H: In. (mm)	9-7/16 (240)
Unit Weight	Lbs. (kg)	31 (13.9)	
Package Weight	Lbs. (kg)	37 (17)	
Indoor Unit Operating Temperature Range	Cooling Intake Air Temp (Maximum / Minimum)*	°F	90F D.B / 73F W.B // 67F D.B / 57F W.B
	Heating Intake Air Temp (Maximum / Minimum)	°F	80F D.B // 70F D.B
Outdoor Unit	MCA	A	14
	MOCP	A	24
	Fan Motor Full Load Amperage	A	0.67
	Fan Motor Output	W	77
	Airflow Rate	CFM	1,691 / 1,691
	Refrigerant Control		LEV
	Defrost Method		Reverse cycle
	Heat Exchanger Type		Plate fin coil
	Sound Pressure Level, Cooling ¹	dB(A)	54
	Sound Pressure Level, Heating ²	dB(A)	55
	Compressor Type		DC INVERTER-driven Twin Rotary
	Compressor Model		SNB130FQBMT
	Compressor Rated Load Amps	A	10.0
	Compressor Locked Rotor Amps	A	12.5
	Compressor Oil Type // Charge	oz.	FV50S//11.8
	External Finish Color		Ivory Munsell 3Y 7.8/1.1
	Base Pan Heater		Optional
	Unit Dimensions	W: In. (mm)	33-1/16 (840)
		D: In. (mm)	13 (330)
		H: In. (mm)	34-5/8 (880)
Package Dimensions	W: In. (mm)	38-9/16 (980)	
	D: In. (mm)	16-9/16 (420)	
	H: In. (mm)	39 (990)	
Unit Weight	Lbs. (kg)	127 (58)	
Package Weight	Lbs. (kg)	145 (66)	
Outdoor Unit Operating Temperature Range	Cooling Air Temp (Maximum / Minimum)*	°F	115 / 14
	Cooling Thermal Lock-out / Re-start Temperatures**	°F	-1 / 3
	Heating Air Temp (Maximum / Minimum)	°F	75 / -4
	Heating Thermal Lock-out / Re-start Temperatures**	°F	-9 / -4
Refrigerant	Type		R410A
	Charge	Lbs, oz	3, 9
Piping	Gas Pipe Size O.D. (Flared)	In.(mm)	1/2 (12.7)
	Liquid Pipe Size O.D. (Flared)	In.(mm)	1/4 (6.35)
	Maximum Piping Length	Ft. (m)	100
	Maximum Height Difference	Ft. (m)	50
	Maximum Number of Bends		10

SPECIFICATIONS: SLZ-KF18NA & SUZ-KA18NA2

Notes

AHRI Rated Conditions (Rated data is determined at a fixed compressor speed)	¹ Cooling (Indoor // Outdoor)	°F	80 DB, 67 WB // 95 DB, 75 WB
	² Heating at 47°F (Indoor // Outdoor)	°F	70 DB, 60 WB // 47 DB, 43 WB
	³ Heating at 17°F (Indoor // Outdoor)	°F	70 DB, 60 WB // 17 DB, 15 WB
Conditions	⁴ Heating at 5°F (Indoor // Outdoor)	°F	70 DB, 60 WB // 5 DB, 4 WB
	⁵ Heating at -4°F (Indoor // Outdoor)	°F	70 DB, 60 WB // -4 DB, -5 WB

*Applications should be restricted to comfort cooling only; equipment cooling applications are not recommended for low ambient temperature conditions.

**System cuts out in heating mode to avoid thermistor error and automatically restarts at these temperatures.

ACCESSORIES: SLZ-KF18NA

Wireless Signal Receiver	□ PAR-FA32MA-W
Wireless Remote Controller	□ PAR-FL32MA-E
Wireless Remote Receiver Panel	□ PAR-SF9FA-E
Wireless Remote Controller	□ PAR-SL100A-E
kumo touch™ RedLINK™ Wireless Controller	□ MHK2
Deluxe MA Remote Controller	□ PAR-40MAAU
Simple MA Controller	□ PAC-YT53CRAU-J
Touch MA Controller	□ PAR-CT01MAU-SB
Wired Remote Sensor	□ PAC-SE41TS-E
Wireless Temperature and Humidity Sensor	□ PAC-USWHS003-TH-1
Flush Mount Remote Temperature Sensor	□ PAC-USSEN001-FM-1
Wireless Interface 2	□ PAC-USWHS002-WF-2
Thermostat Interface	□ PAC-US444CN-1
kumo station®	□ PAC-WHS01HC-E
USNAP Interface	□ PAC-WHS01UP-E
IT Extender	□ PAC-WHS01IE-E
BACnet® and MODBUS® Interface	□ PAC-UKPRC001-CN-1
External Fan / Heater Control Relay Adapter	□ CN24RELAY-KIT-CM3
Wire for Remote on/off with CN32 connector	□ PAC-715AD
Connector and wire for Operation status/error using CN51	□ PAC-725AD
Connector cable for remote display	□ PAC-SA88HA-EP
Remote Operation Adapter ¹	□ PAC-SF40RM-E
Grille (required)	□ SLP-18FAU
3D i-see Sensor® Corner Panel	□ PAC-SF1ME-E
Grille with 3D i-see Sensor®	□ SLP-18FAEU
Blue Diamond Sensor Extension Cable — 15 Ft.	□ C13-103
Blue Diamond Alarm Extension Cable — 6.5 Ft.	□ C13-192
Blue Diamond MultiTank — collection tank for use with multiple pumps	□ C21-014
Blue Diamond Rubber Foot Pads	□ F10-010
Mini Condensate Pump — 230 volt application	□ SI30-230
MegaBlue Advanced Blue Diamond Condensate Pump w/ Reservoir & Sensor	□ X87-835 - 110 to 250V
Advanced Blue Diamond Mini Condensate Pump w/ Reservoir & Sensor (208/230V) [recommended]	□ X87-721 - 208/230V
(30A/600V/UL) [fits 2" X 4" utility box] - Black	□ TAZ-MS303
(30A/600V/UL) [fits 2" X 4" utility box] - White	□ TAZ-MS303W

¹ Unable to use with wireless remote controller

ACCESSORIES: SUZ-KA18NA2

Air Outlet Guide	□ MAC-886SG-E
Optional Defrost Heater	□ MAC-642BH-U1
Hail Guard	□ HG-A7
Outdoor Unit 3-1/4 inch Mounting Base (Pair) - Plastic	□ DSD-400P
Condensing Unit Mounting Pad 16" x 36" x 3"	□ ULTRILITE1
Outdoor Unit Stand — 12" High	□ QSMS1201M
Outdoor Unit Stand — 18" High	□ QSMS1801M
Outdoor Unit Stand — 24" High	□ QSMS2401M
Heavy Duty Wall Mounting Bracket— Coated Steel	□ QSWB2000M-1
Heavy Duty Wall Mounting Bracket— 316 Series Stainless Steel	□ QSWBSS
15' x 1/4" x 15' / 1/2" Lineset (Twin-Tube Insulation)	□ MLS141212T-15
30' x 1/4" x 30' / 1/2" Lineset (Twin-Tube Insulation)	□ MLS141212T-30
50' x 1/4" x 50' / 1/2" Lineset (Twin-Tube Insulation)	□ MLS141212T-50
65' x 1/4" x 65' / 1/2" Lineset (Twin-Tube Insulation)	□ MLS141212T-65
100' x 1/4" x 100' / 1/2" Lineset (Twin-Tube Insulation)	□ MLS141212T-100
10' x 3/8" x 10' x 5/8" Lineset (Twin-Tube Insulation)	□ MPLS385812T-10

DIMENSIONS: SLZ-KF18NA

Unit: inch (mm)

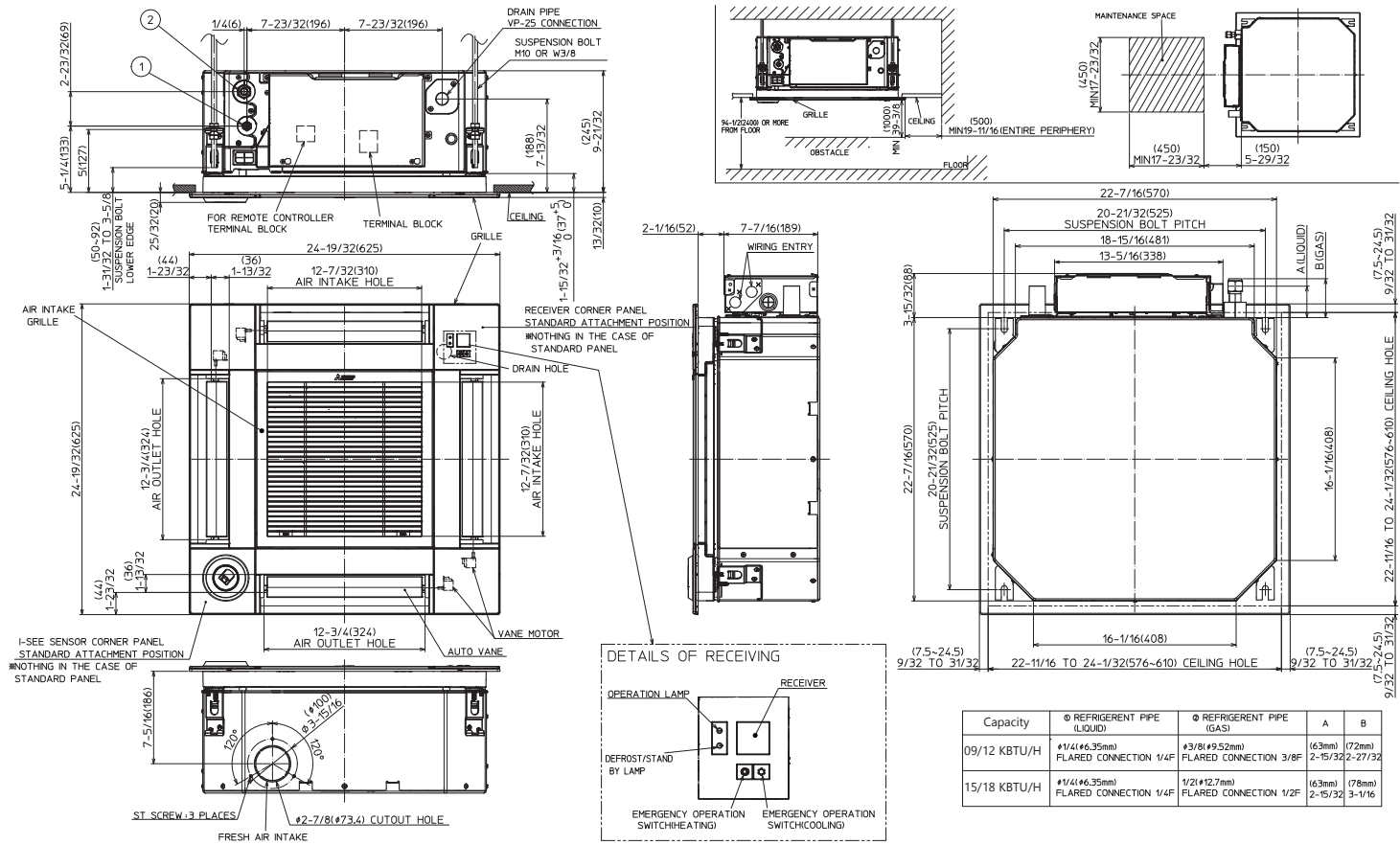

DIMENSIONS: SUZ-KA18NA2

Unit: inch

REQUIRED SPACE

*1 20 in. (500 mm) or more when front and sides of the unit are clear

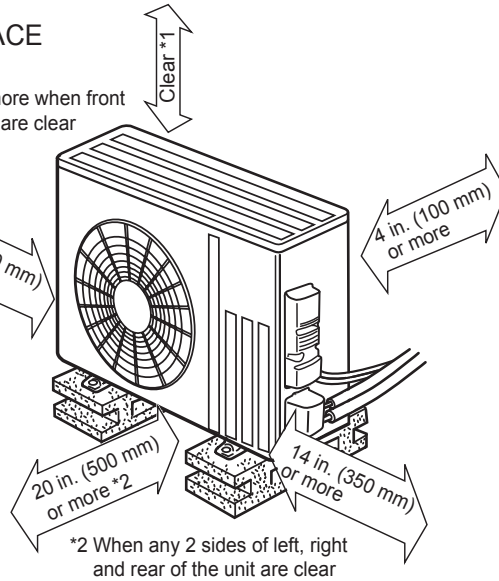

*2 When any 2 sides of left, right and rear of the unit are clear

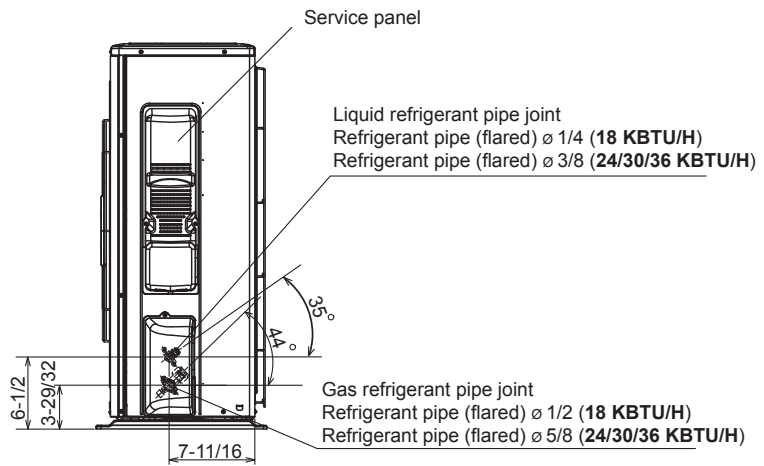
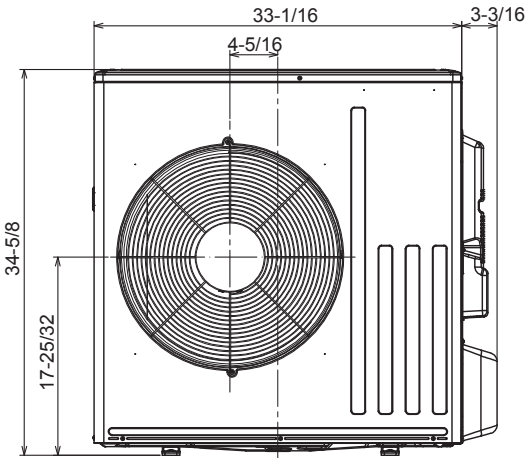
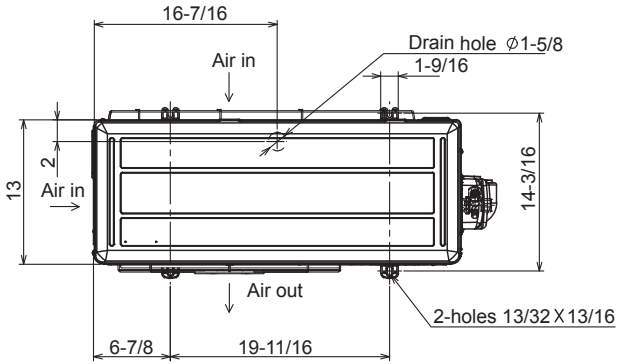

1340 Satellite Boulevard, Suwanee, GA 30024
Toll Free: 800-433-4822 www.mehvac.com

