



MODEL: **WC8AFS-Q**
 WCFS-L/R (Less Refrigeration)



These water coolers are certified to **NSF/ANSI 61**.

GENERAL

Self-contained, electric refrigerated wall-mounted water cooler designed to be easily accessible to physically challenged individuals. When properly installed, unit meets state and federal requirements as defined by the Americans with Disabilities Act. Unit is certified to NSF/ANSI 61 and meets requirements of the Safe Drinking Water Act. Unit provides 50° F water at 80° F inlet water and 90° F ambient.

CABINET

Heavy-gauge vinyl clad steel. Resistant to wear, moisture, perspiration, heat, and sunlight. Optional Stainless Steel is available.

COOLER TOP

Non-corrosive stainless steel cooler top, number 300 series with satin finish resists stains and corrosion and is easy to maintain. Anti-splash ridge reduces splatter. Contoured to insure proper drainage.

BUBBLER

Exclusive one-piece, chrome-plated two-stream mound-building bubbler with non-removable anti-squirt feature and integral hood insures a satisfying drink of water.

PUSH BAR ACTUATION MECHANISM

Self-closing light-touch push bars with raised letters for the visually impaired. **F models have front pushbars only. FS models have pushbars on front and sides.**

AUTOMATIC STREAM HEIGHT REGULATOR

Self-closing assembly is located inside unit to prevent tampering. Unit resists corrosion and liming. A constant stream height is automatically maintained under line pressures that vary from 20 to 105 psi.

INLET STRAINER

Easily cleaned in-line strainer screen traps particles of 140 microns or larger before they enter the waterway.

TEMPERATURE CONTROL

Positive sensing thermostat for controlling temperature of storage tank water. Factory set at 50° F Adjustable ± 5° F.

STORAGE TANK

Non-pressurized stainless steel evaporator/storage tank for long life. Waterways are certified to NSF/ANSI 61, far exceeding the requirements of the Safe Drinking Water Act.

REFRIGERATION SYSTEM

Hermetically sealed, positive start compressor with lifetime lubrication and built-in overload protection, efficient capillary sizing, large capacity dryer-strainer, and self-lubricated fan cools copper/aluminum condenser. System uses R134A refrigerant. Protected by Halsey Taylor's Limited 5 Year Warranty.

VENTILATION

Insure proper ventilation by maintaining 6" (152mm) minimum clearance from cabinet louvers to wall.

SUGGESTED SPECIFICATIONS

Shall deliver 8.0 GPH of 50° F water at 90° F ambient and 80° F inlet water. Shall have stainless steel basin with removable drain strainer. Bubbler shall be two-stream mound building type. Separate valve and automatic stream regulator shall be mounted within cabinet. Refrigeration system shall employ high efficiency, positive start compressor using R134A, non-pressurized tank with totally encapsulated insulation and be controlled by positive sensing thermostat. Shall have front (or front and side) push-bar water controls with raised lettering for the visually impaired. Cooler shall comply with ANSI 117:1 and ADA for visual and motion disabilities. The manufacturer shall certify the unit to meet the requirements of NSF/ANSI 61, and the Safe Drinking Water Act. Unit complies with ARI Standard 1010.

NOTE: Continued product improvement makes specifications subject to change without notice. See Halsey Taylor website for most current spec sheet.

Barrier-Free Cooler



Standard finish is Platinum Vinyl

Optional Vinyl Finishes Available (no extra cost)

- Slate
- Almond

Optional Finishes (extra cost)

- All Stainless Steel

Optional Accessories (extra cost)

- Water Filter
- Vandal-Resistant Kit
- Easy-Flex™ Bubbler

JOB NAME: _____

 ENGINEER/CONTRACTOR NAME:

 APPROVAL: _____
 DATE: _____

WC8 BARRIER-FREE SERIES

Model No.	GPH Capacity Cooled to 50° F*				Base Rate Cap.	F.L. Amps	Shipping Weight lb.	Rated Watt Usage
	Ambient Air Temp							
	70°F	80°F	90°F†	100°F				
WC8AFS-Q	9.2	8.4	7.6	6.8	7.6	4.0	70	370

* With projector service and tap water at 80° F

† UL listed and complies with ARI Standard 1010

Trap and service stop not included



WC8AFS-Q, WCFS-L/R

Barrier-Free Cooler

(CONTINUED)

MOUNTING HEIGHT

Mounting height recommended 34 1/8" from basin to floor. May be mounted at any desired height. Check local codes.

MOUNTING INSTRUCTIONS

Mount trap and install service stop to building supply line. Anchor hanger bracket securely to wall on all sides. To insure proper engaging of waste line into trap, centerline of trap must be 15 1/4" from wall face. Remove slip nut and gasket from trap and install on waste line tube. Hang cooler on bracket and engage waste line tube into trap inlet. Centerline height of waste outlet will vary from floor line depending on mounting height. Install 3/8" supply tube to in-line strainer.

Trap and service stop not included.

OPERATING PRESSURES:

Supply water - 105 psi maximum

ELECTRICAL

Furnished with plug-in, 3-wire grounding type service cord. Standard 120 volt, 60 Hz, single phase. Install 120-volt receptacle, rated at 15-amp minimum, to receive 3-wire parallel blade grounding type male plug.

FRONT VIEW

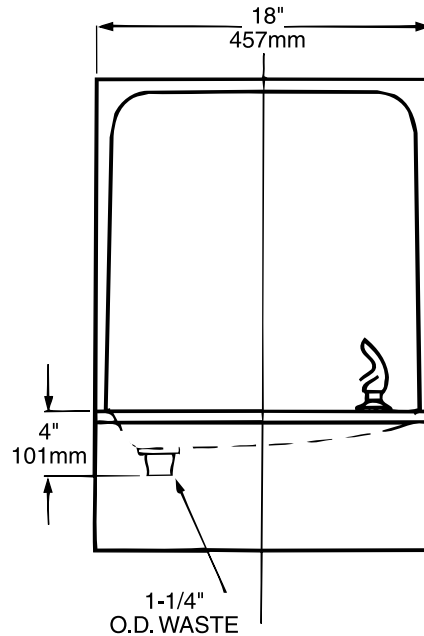

SIDE VIEW

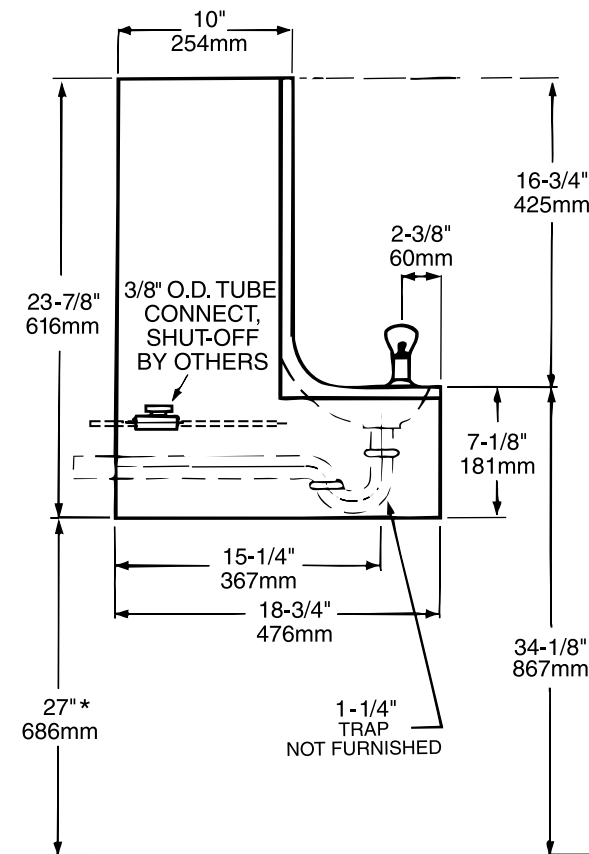

WALL LAYOUT

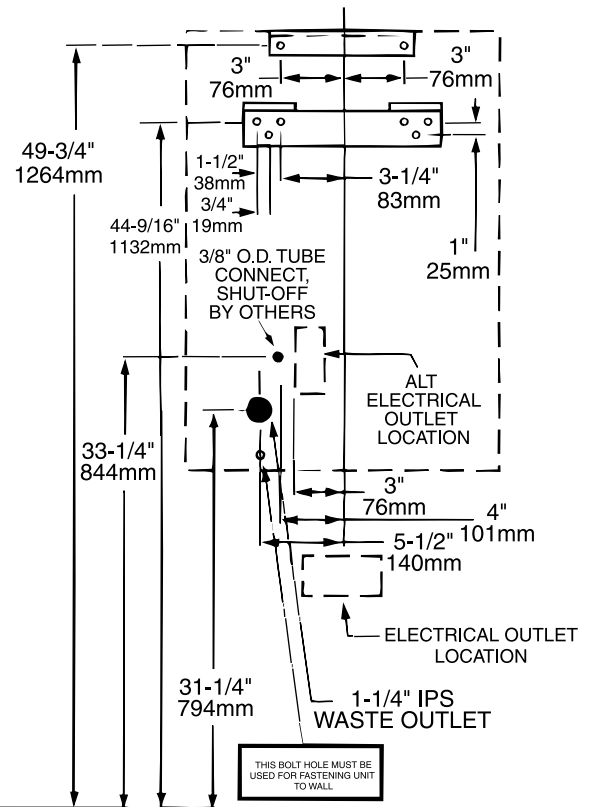

NOTE: A service supply stop must be installed at the cooler inlet tube.
*ADA Requirement

Halsey Taylor