

FEATURES

- Brass valve body
- Pressure-balancing diaphragm design valve
- One-piece diaphragm cartridge design for ease of maintenance
- Mixing valve cycles from "cold" to "hot"
- High-temperature limit setting for added safety

CODES/STANDARDS APPLICABLE

Specified model meets or exceeds the following:

- ASME A112.18.1/CSA B125.1
- ASSE 1016

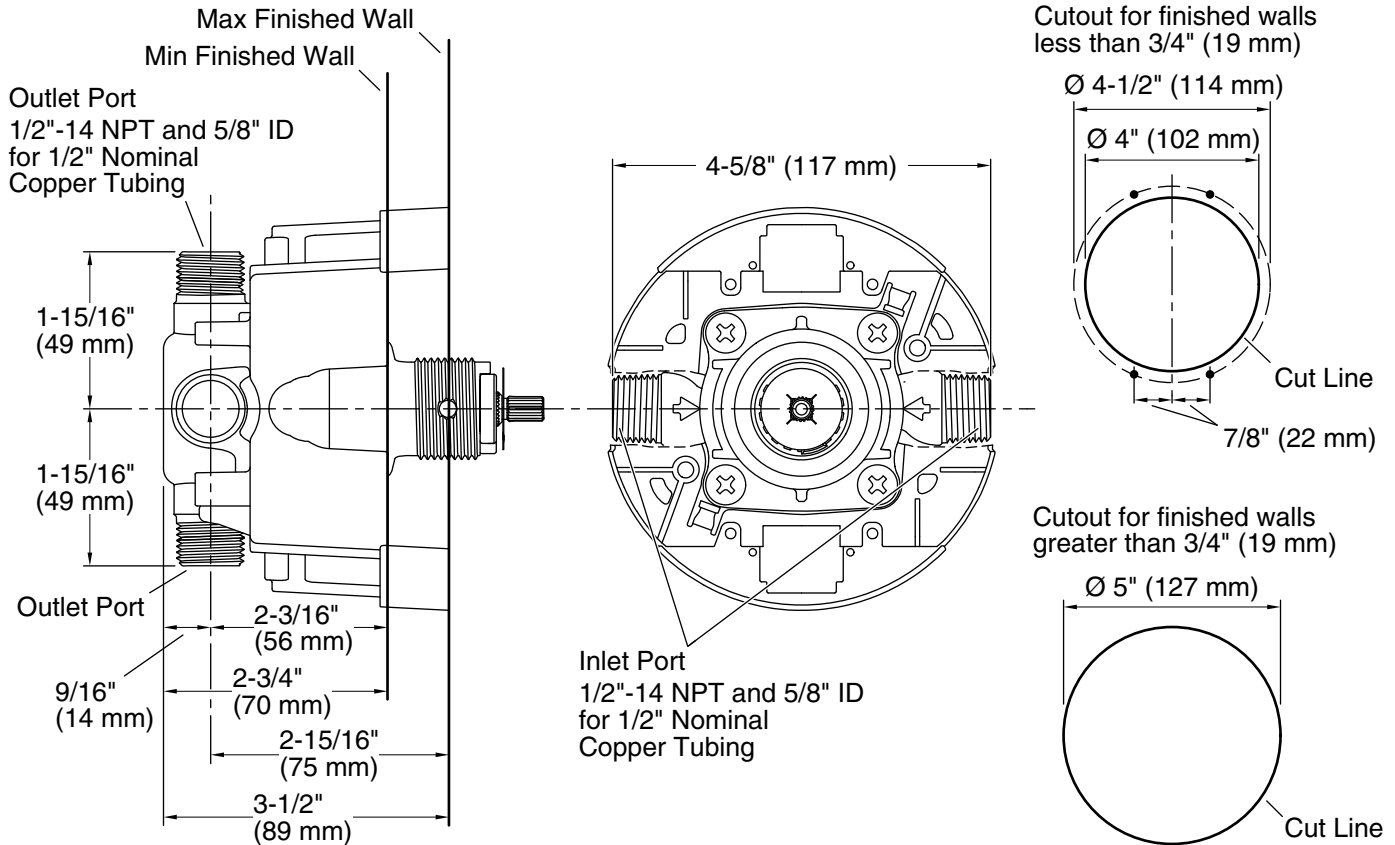

INSTALLATION NOTES

All dimensions are nominal.
Install this product according to the installation guide.
Avoid cross-flow conditions. Do not install shut-off device on either valve outlet.
Cap the shower outlet if deck-mount spout, diverter, or handshower is connected to the spout outlet.
Install straight pipe or tube drop of 7" (178 mm) to 18" (457 mm) with single elbow between the valve and wall-mount spout.
For finished walls greater than 3/4" (19 mm) and less than 1-1/2" (38 mm), install support(s) 2" (51 mm) from the stud face.
For finished walls greater than 1-1/2" (38 mm), install support(s) 3" (76 mm) from the face of the finished wall.

SPECIFIED MODEL

Model	Description	Finishes
P19310-00	Pressure-Balancing Valve, without screwdriver stops	<input type="checkbox"/> NA
Optional Accessory		
10350-NA	Universal Rite-Temp® Valve Deep Rough-In	<input type="checkbox"/> NA

We reserve the right to make revisions without notice in the design of products or in packaging unless this right has specifically been waived at the time the order is accepted.