



# Z1212

## WALL CLOSET SUPPORT SYSTEM

SPECIFICATION SHEET

TAG \_\_\_\_\_

Dimensional Data (inches and [ mm ]) are Subject to Manufacturing Tolerances and Change Without Notice

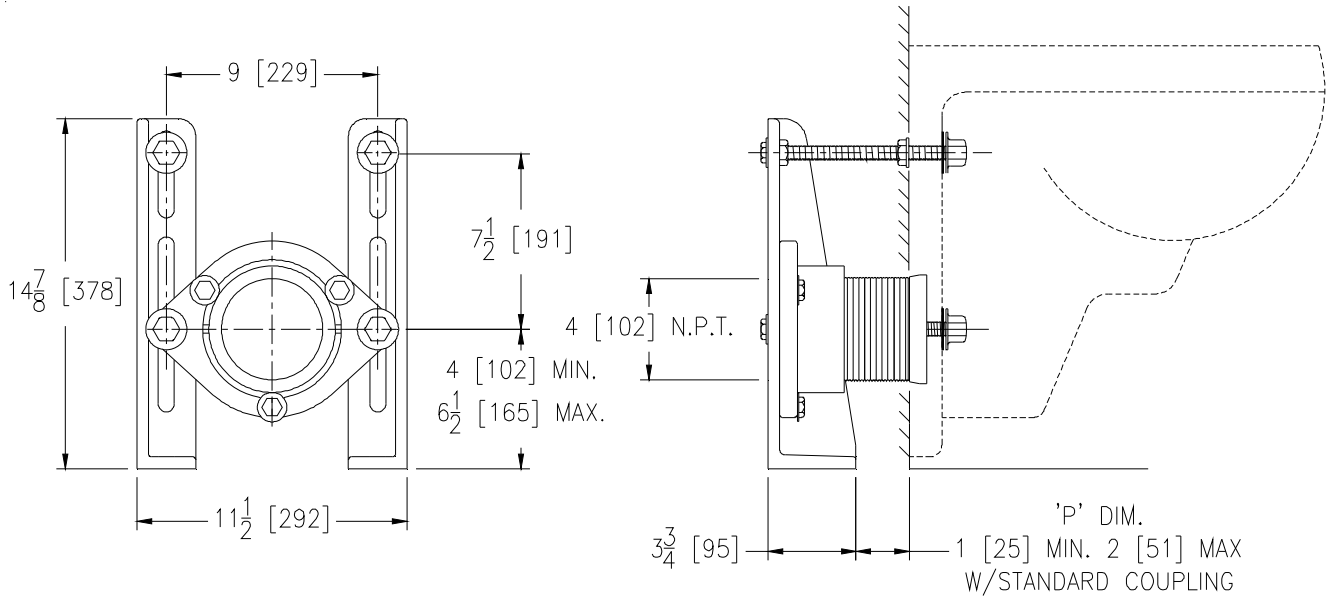

Product No.	Approx. Wt. Lbs. [kg]
Z1212	30 [14]

**ENGINEERING SPECIFICATION: ZURN Z1212**

Dura-Coated cast iron wall closet support system. Complete with adjustable faceplate rigidly mounted on reversible foot supports. ABS coupling with integral test cap, fixture bolts, trim, stud protectors and bonded "Neo-Seal" gasket.

**OPTIONS** (Check/specify appropriate options)

**PREFIXES**

\_\_\_ Z D.C.C.I. System with Zurn "ZZ" Coupling Connection\*

**SUFFIXES**

- \_\_\_ -B Adapter for Blowout Type Fixture Support
- \_\_\_ -CL Coupling Length Greater than 12 [305] (Specify length required)
- \_\_\_ -F Floor Mount, Back Outlet Fixture Support
- \_\_\_ -G Galvanized Cast Iron
- \_\_\_ -VP Vandal Proof Finish Trim
- \_\_\_ -X4 4 [102] Carrier Foot Extension Assembly
- \_\_\_ -29 Mechanical Test Cap Assembly
- \_\_\_ -45 Finishing Frame for Siphon Jet System (For Blowout System Specify -45-B)  
(Previously Z1210-45)
- \_\_\_ -61 Adjusting Wrench for "ZZ" Coupling
- \_\_\_ -77 Retrofit Cap Nuts

Note: For plastic pipe installation use male thread by socket adapter  
 DO NOT THREAD PLASTIC PIPE. (Per ASTM Specification #D2665X1.6.1.)  
 Piping must be rigidly secured to prevent deflection (by others).

REV. F	DATE: 11/19/10	C.N. NO. 120491
DWG. NO. 58845	PRODUCT NO. Z1212	

\*REGULARLY FURNISHED UNLESS OTHERWISE SPECIFIED

ZURN INDUSTRIES, LLC. ♦ SPECIFICATION DRAINAGE OPERATION ♦ 1801 Pittsburgh Ave. ♦ Erie, PA 16514

Phone: 814/455-0921 ♦ Fax: 814/454-7929 ♦ World Wide Web: www.zurn.com

In Canada: ZURN INDUSTRIES LIMITED ♦ 3544 Nashua Drive ♦ Mississauga, Ontario L4V1L2 ♦ Phone: 905/405-8272 Fax: 905/405-1292