

**PEAD-A12AA7 & PUZ-A12NKA7(-BS)
12,000 BTU/H HORIZONTAL MID STATIC DUCTED
12,000 BTU/H HEAT PUMP UNIVERSAL OUTDOOR**



Job Name:

System Reference:

Date:



Indoor Unit.....PEAD-A12AA7

Outdoor Unit
Standard Model.....PUZ-A12NKA7

Seacoast Model.....PUZ-A12NKA7-BS

INDOOR UNIT FEATURES

- Unobtrusive ceiling-concealed design for short-run ductwork
- Wide ranging external static pressure (0.14-0.60 in. WG)
- Built-in condensate lift mechanism (up to 27-9/16")
- Auto fan speed mode
- Optional FB Series filter boxes for easy access and service
- Ideal for residential homes, retail shopping centers, larger classrooms, office complexes, conference rooms, ballrooms, fitness centers, and more
- Multiple control options available:
 - kumo cloud® smart device app for remote access
 - Third-party interface options
 - Wired or wireless controllers

OUTDOOR UNIT FEATURES

- Variable speed INVERTER-driven compressor
- Power receiver pre-charged with refrigerant volume for piping length up to 70 ft
- Low ambient cooling down to -40°F providing 100% capacity (only for PUY models with wind baffles installed)
- 24-hour continuous operation (cooling mode)
- High pressure protection
- Fast restart due to bypass valve make it ideal for equipment cooling applications, such as data centers
- Superior energy and operational efficiency

SPECIFICATIONS: PEAD-A12AA7 & PUZ-A12NKA7(-BS)

Cooling at 95°F ¹	Maximum Capacity	BTU/H	12,000
	Rated Capacity	BTU/H	12,000
	Minimum Capacity	BTU/H	5,000
	Maximum Power Input	W	920
	Rated Power Input	W	920
	Moisture Removal	Pints/h	1.8
	Sensible Heat Factor		0.83
Heating at 47°F ²	Power Factor	%	90.9/90.9
	Maximum Capacity	BTU/H	18,000
	Rated Capacity	BTU/H	14,000
	Minimum Capacity	BTU/H	5,800
	Maximum Power Input	W	1,520
	Rated Power Input	W	1,030
Heating at 17°F ³	Power Factor	%	91.4/91.4
	Maximum Capacity	BTU/H	10,500
	Rated Capacity	BTU/H	8,700
	Maximum Power Input	W	1,130
Heating at 5°F ⁴	Rated Power Input	W	1,100
	Maximum Capacity	BTU/H	10,000
Heating at 5°F ⁴	Maximum Power Input	W	1,500
	SEER		21.1
Efficiency	EER ¹		13.0
	HSPF [IV]		10.2
	COP at 47°F ²		3.98
	COP at 17°F at Maximum Capacity ³		2.73
	COP at 5°F at Maximum Capacity ⁴		1.95
	ENERGY STAR® Certified		Yes
Electrical	Voltage, Phase, Frequency		208/230, 1, 60
	Guaranteed Voltage Range	V AC	198 - 253
	Voltage: Indoor - Outdoor, S1-S2	V AC	208/230
	Voltage: Indoor - Outdoor, S2-S3	V DC	24
	Short-circuit Current Rating [SCCR]	kA	5
	Recommended Fuse/Breaker Size (Outdoor)	A	15
	Recommended Wire Size [Indoor - Outdoor]	AWG	14
Indoor Unit	MCA	A	1.45
	Fan Motor Full Load Amperage	A	1.16
	Fan Motor Output	W	85
	Airflow Rate at Cooling, Dry	CFM	353–424–494
	Airflow Rate at Cooling, Wet	CFM	318–382–445
	Airflow Rate at Heating, Dry	CFM	353–424–494
	Sound Pressure Level [Cooling]	dB[A]	28–30–34
	Sound Pressure Level [Heating]	dB[A]	28–30–34
	External Static Pressure	in.WG	0.14–0.2–0.28–0.4–0.6
	Drain Pipe Size	In. [mm]	1-1/4 [32]
	Condensate Lift Mechanism, Maximum Distance	In. [mm]	27-9/16 [700]
	Coating on Heat Exchanger		—
	External Finish Color		Galvanized
	Unit Dimensions	W x D x H: In. [mm]	35-7/16 x 28-7/8 x 9-7/8 [900 x 732 x 250]
	Package Dimensions	W x D x H: In. [mm]	45-5/16 x 34-11/16 x 13-7/16 [1150 x 880 x 341]
Unit Weight	Lbs. [kg]	58 [26]	
Package Weight	Lbs. [kg]	69 [31]	
Indoor Unit Operating Temperature Range	Cooling Intake Air Temp [Maximum / Minimum]*	°F	95 DB, 71 WB / 67 DB, 57 WB
	Heating Intake Air Temp [Maximum / Minimum]	°F	80 DB / 70 DB

NOTES:

AHRI Rated Conditions (Rated data is determined at a fixed compressor speed)	¹ Cooling (Indoor // Outdoor)	°F	80 DB, 67 WB // 95 DB, 75 WB
	² Heating at 47°F (Indoor // Outdoor)	°F	70 DB, 60 WB // 47 DB, 43 WB
	³ Heating at 17°F (Indoor // Outdoor)	°F	70 DB, 60 WB // 17 DB, 15 WB
Conditions	⁴ Heating at 5°F (Indoor // Outdoor)	°F	70 DB, 60 WB // 5 DB, 4 WB
	⁵ Heating at -4°F (Indoor // Outdoor)	°F	70 DB, 60 WB // -4 DB, -5 WB
	⁶ Heating at -5°F (Indoor // Outdoor)	°F	70 DB, 60 WB // -5 DB, -6 WB
	⁷ Heating at -13°F (Indoor // Outdoor)	°F	70 DB, 60 WB // -13 DB, -14 WB

*Outdoor Unit Operating Temperature Range (Cooling Air Temp (Maximum / Minimum)):

- Applications should be restricted to comfort cooling only; equipment cooling applications are not recommended for low ambient temperature conditions.
 - » Wind baffles required to operate below 23°F DB in cooling mode.
 - » Cooling-only system with wind baffle: -40°F - 115°F.
 - » Heat pump system with wind baffle: 0°F - 115°F.
 - » Refer to wind baffle documentation for further information.

**Outdoor Unit Operating Temperature Range (Cooling Thermal Lock-out / Re-start Temperatures; Heating Thermal Lock-out / Re-start Temperatures):

- System cuts out in heating mode to avoid thermistor error and automatically restarts at these temperatures.

SEACOAST PROTECTION (-BS MODELS)

- External Outer Panel: Phosphate coating + Acrylic-Enamel coating
- Fan Motor Support: Epoxy resin coating (at edge face)
- Separator Assembly Valve Bed: Epoxy resin coating (at edge face)
- Blue Fin treatment is an anti-corrosion treatment that is applied to the condenser coil to protect it against airborne contaminants.

SPECIFICATIONS: PEAD-A12AA7 & PUZ-A12NKA7(-BS)

Outdoor Unit	MCA	A	11.0	
	MOCP	A	28	
	Fan Motor Full Load Amperage	A	0.5	
	Fan Motor Output	W	46	
	Airflow Rate	CFM	1590/1590	
	Refrigerant Control		LEV	
	Defrost Method		Reverse Cycle	
	Coating on Heat Exchanger		Blue Fin Coating (BS Model only)	
	Sound Pressure Level, Cooling ¹	dB(A)	44	
	Sound Pressure Level, Heating ²	dB(A)	46	
	Compressor Type		INVERTER-driven twin rotary	
	Compressor Model		SNB092FNCM	
	Compressor Rated Load Amps	A	7.0	
	Compressor Locked Rotor Amps	A	12.0	
	Compressor Oil Type // Charge	oz.	FV50S // 12	
	External Finish Color		Ivory Munsell 3Y 7.8/1.1	
	Base Pan Heater		N/A	
	Unit Dimensions	W x D x H: In. [mm]	31-13/16 (+7/16) x 11-3/16 x 24-13/16 [809 (+62) x 300 x 630]	
	Package Dimensions	W x D x H: In. [mm]	37-1/16 x 16-3/16 x 27-7/16 [941 x 411 x 670]	
	Unit Weight	Lbs. [kg]	93 [42]	
	Package Weight	Lbs. [kg]	104 [47]	
	Outdoor Unit Operating Temperature Range	Cooling Air Temp [Maximum / Minimum]*	°F	115 DB / 0 DB
		Heating Air Temp [Maximum / Minimum]	°F	70 DB, 59 WB / 12 DB, 10 WB
Heating Thermal Lock-out / Re-start Temperatures**		°F	8.0 / 12	
Refrigerant	Type		R410A	
	Charge	Lbs, oz	4, 7.0	
	Chargeless Piping Length	Ft. [m]	70.0 [20.0]	
	Additional Refrigerant Charge Per Additional Piping Length	oz./Ft. [g/m]	0.2 [15]	
Piping	Gas Pipe Size O.D. [Flared]	In.[mm]	1/2 [12.7]	
	Liquid Pipe Size O.D. [Flared]	In.[mm]	1/4 [6.35]	
	Maximum Piping Length	Ft. [m]	100 [30]	
	Maximum Height Difference	Ft. [m]	100 [30]	
	Maximum Number of Bends		15	

NOTES:

AHRI Rated Conditions
 (Rated data is determined at a fixed compressor speed)

¹ Cooling (Indoor // Outdoor)	°F	80 DB, 67 WB // 95 DB, 75 WB
² Heating at 47°F (Indoor // Outdoor)	°F	70 DB, 60 WB // 47 DB, 43 WB
³ Heating at 17°F (Indoor // Outdoor)	°F	70 DB, 60 WB // 17 DB, 15 WB

Conditions

⁴ Heating at 5°F (Indoor // Outdoor)	°F	70 DB, 60 WB // 5 DB, 4 WB
⁵ Heating at -4°F (Indoor // Outdoor)	°F	70 DB, 60 WB // -4 DB, -5 WB
⁶ Heating at -5°F (Indoor // Outdoor)	°F	70 DB, 60 WB // -5 DB, -6 WB
⁷ Heating at -13°F (Indoor // Outdoor)	°F	70 DB, 60 WB // -13 DB, -14 WB

*Outdoor Unit Operating Temperature Range (Cooling Air Temp (Maximum / Minimum)):

- Applications should be restricted to comfort cooling only; equipment cooling applications are not recommended for low ambient temperature conditions.
 - » Wind baffles required to operate below 23°F DB in cooling mode.
 - » Cooling-only system with wind baffle: -40°F - 115°F.
 - » Heat pump system with wind baffle: 0°F - 115°F.
 - » Refer to wind baffle documentation for further information.

**Outdoor Unit Operating Temperature Range (Cooling Thermal Lock-out / Re-start Temperatures; Heating Thermal Lock-out / Re-start Temperatures):

- System cuts out in heating mode to avoid thermistor error and automatically restarts at these temperatures.
- SEACOAST PROTECTION (-BS MODELS)**
- External Outer Panel: Phosphate coating + Acrylic-Enamel coating
 - Fan Motor Support: Epoxy resin coating (at edge face)
 - Separator Assembly Valve Bed: Epoxy resin coating (at edge face)
 - Blue Fin treatment is an anti-corrosion treatment that is applied to the condenser coil to protect it against airborne contaminants.

INDOOR UNIT ACCESSORIES: PEAD-A12AA7

Control Interface	3-Pin Connector	PAC-715AD
	BACnet® and Modbus Interface	PAC-UKPRC001-CN-1
	CN24 Relay Kit	CN24RELAY-KIT-CM3
	Connector cable for remote display	PAC-SA88HA-EP
	IT Extender	PAC-WHS01IE-E
	kumo station® for kumo cloud®	PAC-WHS01HC-E
	Lockdown bracket for remote controller	RCMKP1CB
	Remote Operation Adapter†	PAC-SF40RM-E
	Thermostat Interface	PAC-US444CN-1
	USNAP Adapter	PAC-WHS01UP-E
	Wireless Interface for kumo cloud®	PAC-USWHS002-WF-2
Remote Sensor	Flush Mount Temperature Sensor	PAC-USSEN001-FM-1
	Remote Temperature Sensor	PAC-SE41TS-E
	Wireless temperature and humidity sensor for kumo cloud®	PAC-USWHS003-TH-1
Wired Remote Controller	Airzone ZBS Wired Blueface Principal Controller White	AZZBSBLUEFACECB
	Airzone ZBS Wired Lite Controller White	AZZBSLITECB
	Airzone ZBS Wired Think Controller White	AZZBSTHINKCB
	Airzone ZBS Wireless Lite Controller White	AZZBSLITERB
	Airzone ZBS Wireless Think Controller White	AZZBSTHINKRB
	Deluxe Wired MA Remote Controller†	PAR-40MAAU
	Simple MA Remote Controller†	PAC-YT53CRAU-J
	Touch MA Controller†	PAR-CT01MAU-SB
Wireless Remote Controller	kumo touch™ RedLINK™ Wireless Controller	MHK2
	Wireless MA Receiver	PAR-FA32MA-W
	Wireless MA Remote Controller	PAR-FL32MA-E
Condensate	Blue Diamond (Advanced) Mini Condensate Pump w/ Reservoir & Sensor (208/230V) [recommended]	X87-721
	Blue Diamond (MegaBlue Advanced) Condensate Pump w/ Reservoir & Sensor	X87-835
	Blue Diamond Sensor Extension Cable — 15 Ft.	C13-103
Control Wire	20/2PR, 1PR shielded + 1PR plenum wire for Airzone, 100 ft reel	CW2042S2-100
	20/2PR, shielded + 1PR plenum wire for Airzone, 500 ft reel	CW2042S2-500
Disconnect Switch	(30A/600V/UL) [fits 2" X 4" utility box] - Black	TAZ-MS303
	(30A/600V/UL) [fits 2" X 4" utility box] - White	TAZ-MS303W
Filter Box	Filter Box with MERV 13 Filter	FBM2-2-A
Lineset	100' x 1/4" x 100' / 1/2" Lineset (Twin-Tube Insulation)	MLS141212T-100
	15' x 1/4" x 15' / 1/2" Lineset (Twin-Tube Insulation)	MLS141212T-15
	30' x 1/4" x 30' / 1/2" Lineset (Twin-Tube Insulation)	MLS141212T-30
	50' x 1/4" x 50' / 1/2" Lineset (Twin-Tube Insulation)	MLS141212T-50
	65' x 1/4" x 65' / 1/2" Lineset (Twin-Tube Insulation)	MLS141212T-65

NOTES:

- †PAC-SF40RM-E (Unable to use with wireless remote controller)
 • Ceiling Cassette, Ceiling Suspended, Horizontal-ducted and Multi-position Air Handler

OUTDOOR UNIT ACCESSORIES: PUZ-A12NKA7(-BS)

Air Outlet Guide	Air Outlet Guide	PAC-SJ07SG-E
Centralized Drain Pan	Centralized Drain Pan	PAC-SG63DP-E
Control/Service Tool	Control/Service Tool	PAC-SK52ST
	M- & P-Series Maintenance Tool Cable Set	M21EC0397
	USB/UART Conversion Cable (Required for all laptop connection)	M21EC1397
Drain Socket	Drain Socket	PAC-SJ08DS-E
Hail Guards	Hail Guard	HG-A5
M-NET Converter	M-NET Converter	PAC-SJ96MA-E
Mini-Split Wire	14 Gauge, 4 wire MiniSplit Cable—250 ft. roll	S144-250
	14 Gauge, 4 wire MiniSplit Cable—50 ft. roll	S144-50
	16 Gauge, 4 wire MiniSplit Cable—250 ft. roll	S164-250
	16 Gauge, 4 wire MiniSplit Cable—50 ft. roll	S164-50
Mounting Pad	Condensing Unit Mounting Pad: 16" x 36" x 3"	ULTRILITE1
Stand	18" Single Fan Stand	QSMS1801M
	24" Single Fan Stand	QSMS2401M
	Condenser Wall Bracket	QSWB2000M-1
	Condenser Wall Bracket -Stainless Steel Finish	QSWBSS
	Outdoor Unit Stand — 12" High	QSMS1201M
Wind Baffle	Front Wind Baffle	WB-PA4
	Rear Wind Baffle	WB-RE4
	Side Advanced Wind Baffle	WB-SD4

INDOOR UNIT DIMENSIONS: PEAD-A12AA7

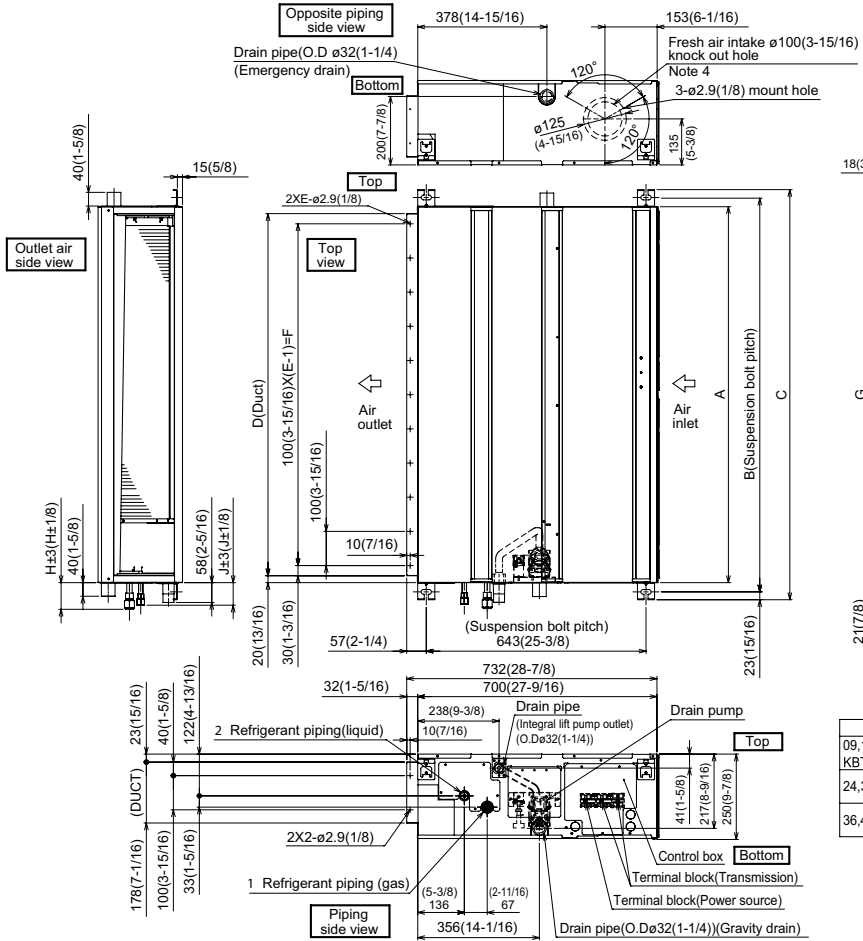

- Note 1. Use an M10 screw for the suspension bolt (field supply).
 2. Keep the service space for maintenance at the bottom.
 3. This drawing is for 24·30·36·42 KBTU/H models, which have 2 fans.
 09·12·15·18 KBTU/H models have 1 fan.
 4. If the inlet duct is used, remove the air filter (supplied with the unit), then install the filter (field supply) at the suction side.
 5. Heat air to 0°C (32°F) or higher when taking fresh air with a fresh air intake.

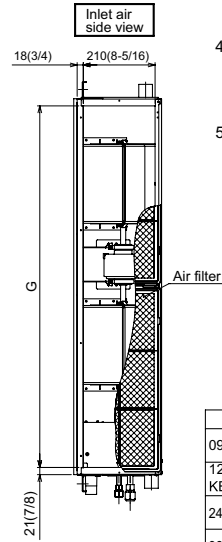

Unit:mm(in.)

Model	J	1 Gas pipe	2 Liquid pipe
09 KBTU/H	62 (2-1/2)	ø9.52 (3/8)	ø6.35 (1/4)
12, 15, 18 KBTU/H	62 (2-1/2)	ø12.7 (1/2)	ø6.35 (1/4)
24, 30 KBTU/H	66 (2-5/8)	ø15.88 (5/8)	ø9.52 (3/8)
36, 42 KBTU/H			

Unit:mm(in.)

Model	A	B	C	D	E	F	G	H
09, 12, 15, 18 KBTU/H	900 (35-7/16)	954 (37-9/16)	1000 (39-3/8)	860 (33-7/8)	9	800 (31-1/2)	858 (33-13/16)	72 (2-7/8)
24, 30 KBTU/H	1100 (43-5/16)	1154 (45-7/16)	1200 (47-1/4)	1060 (41-3/4)	11	1000 (39-3/8)	1058 (41-11/16)	78 (3-1/8)
36, 42 KBTU/H	1400 (55-1/8)	1454 (57-1/4)	1500 (59-1/16)	1360 (53-9/16)	14	1300 (51-3/16)	1358 (53-1/2)	

OUTDOOR UNIT DIMENSIONS: PUZ-A12NKA7(-BS)

Unit: mm<in>



Free space around the outdoor unit (basic example)

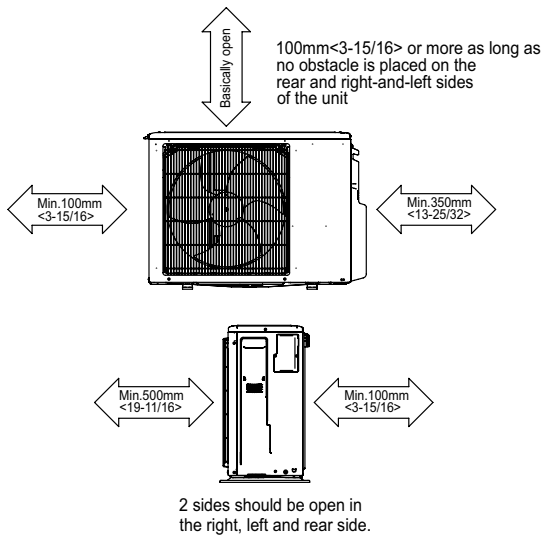

FOUNDATION BOLTS

Please secure the unit firmly with 4 foundation (M10<W3/8>) bolts. (Bolts, washers and nut must be purchased locally).

<Foundation bolt height>

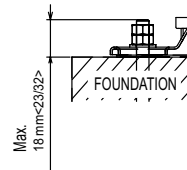

PIPING-WIRING DIRECTION

Piping and wiring connection can be made from the rear direction only.