



Z1253

SPECIFICATION SHEET

**ADJUSTABLE CONCEALED ARM SYSTEM
WALL SUPPORTED**

TAG _____

Dimensional Data (inches and [mm]) are Subject to Manufacturing Tolerances and Change Without Notice

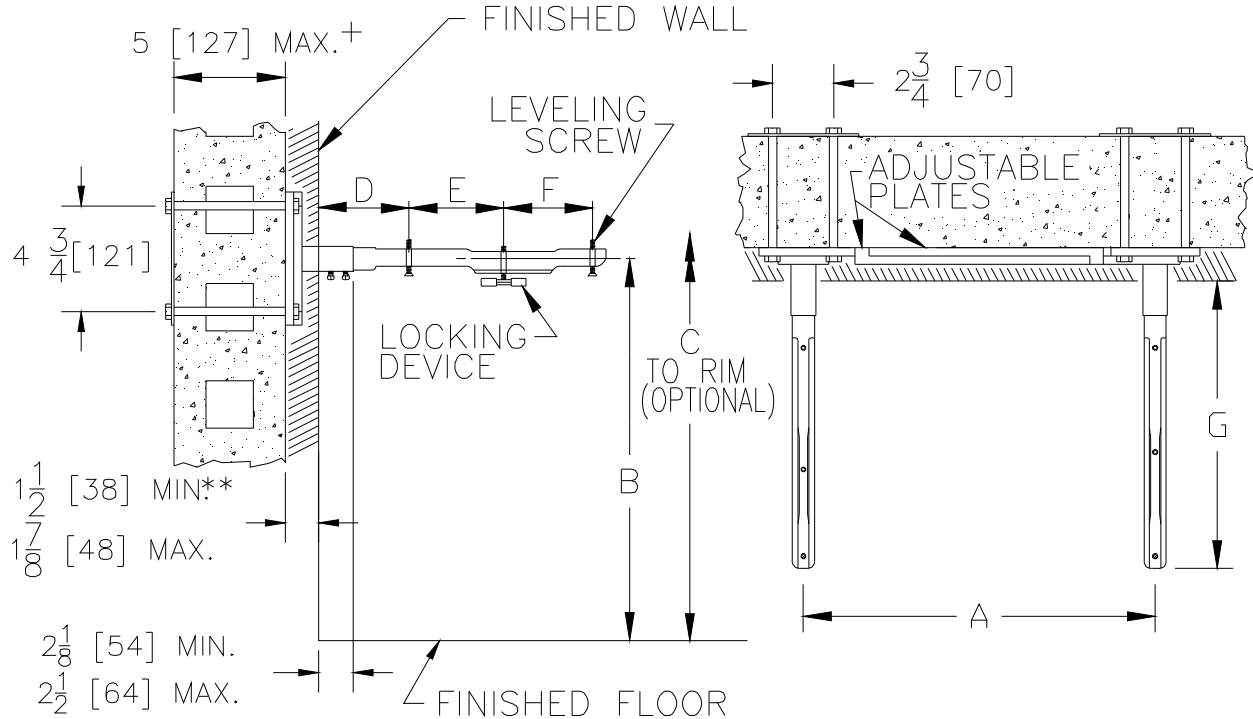

** WITH STANDARD SLEEVE LENGTH OF 4 [102]
+ WITH STANDARD STUD LENGTH OF 6 [152]

Product No.	Approx. Wt. Lbs. [kg]
Z1253	18 [8]

ENGINEERING SPECIFICATION: ZURN Z1253

Lavatory support with concealed arms. Complete with adjustable Dura-Coated support plates with arm sleeves, concealed arms, and mounting fasteners.

OPTIONS (Check/specify appropriate options)

PREFIXES

___ Z Dura-Coated System with Concealed Arms*

SUFFIXES

- ___ -E2 Concealed Arm Escutcheons 2 [51] Long
- ___ -E4 Concealed Arm Escutcheons 4 [102] Long
- ___ -E6 Concealed Arm Escutcheons 6 [152] Long
- ___ -SL Sleeve Length Over 4 [102] (Specify Length)
- ___ -79 Paraplegic Rough-in

Note: Dimensional data for letter dimensions depends upon fixture type and manufacturer. See Zurn Carrier/Fixture Rough-In information at www.zurn.com for specific rough-in dimensions

*REGULARLY FURNISHED UNLESS OTHERWISE SPECIFIED

REV. E	DATE: 10/20/10	111891
DWG. NO. 58858	PRODUCT NO. Z1253	