

## Features

- High quality full brass construction for durability and reliability
- Sold as a pair
- Adjustable escutcheon

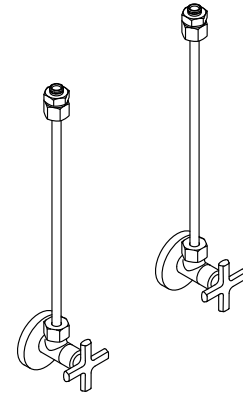

## Codes/Standards



ASME A112.18.1/CSA B125.1  
NSF/ANSI/CAN 61  
NSF/ANSI/CAN 372  
All applicable US Federal and State  
material regulations

## KALLISTA® Five-Year Limited Warranty

See website for detailed warranty  
information.

## Available Colors/Finishes

*Color tiles intended for reference only.*

Color	Code	Description
	AD	Nickel Silver
	BN	Brushed Nickel

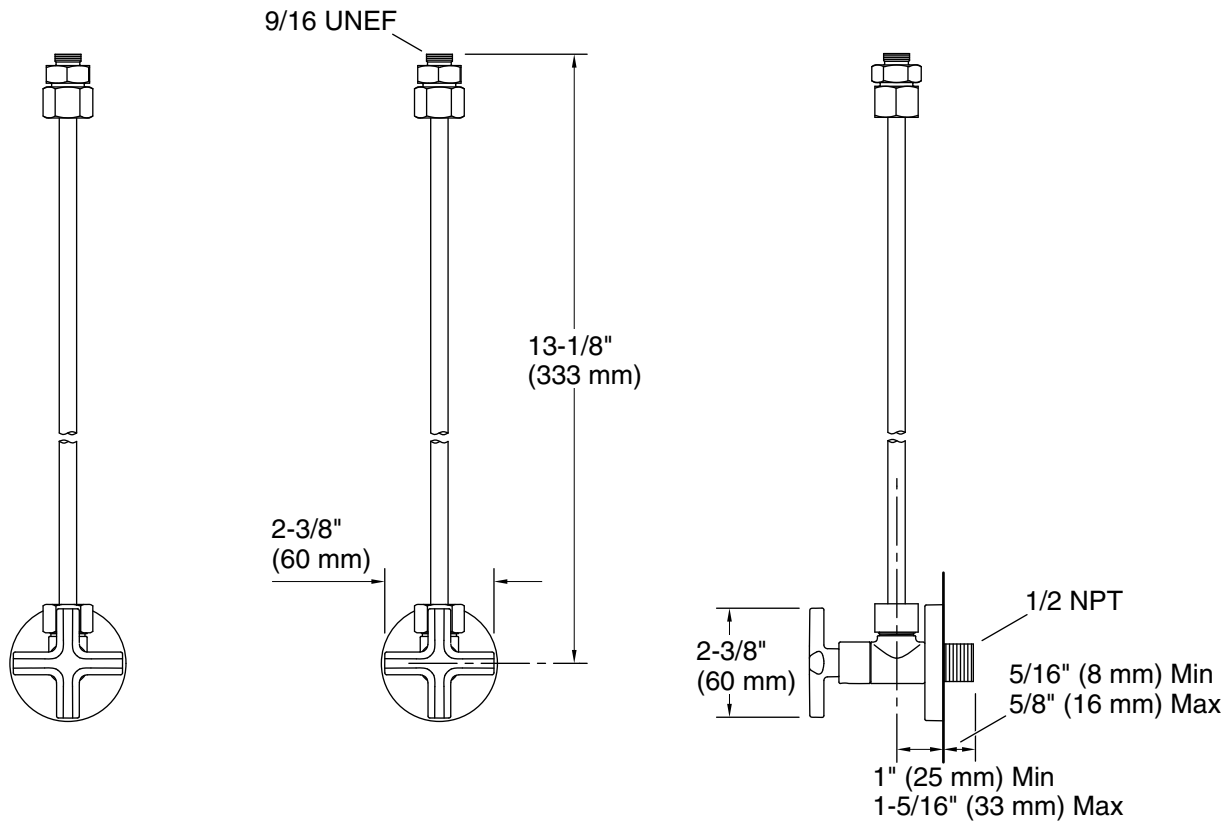

## Technical Information

All product dimensions are nominal.

Drain included: No

Drain with  
overflow: No

## Notes

Install this product according to the installation instructions.