



# Z5675-BWL

TAG \_\_\_\_\_

## HET Children's Floor Mounted EcoVantage® Flush Valve Toilet



### Z5675 HET Series

- Zurn High Efficiency Toilets and paired performance flush valve systems are designed to exceed industry standards, while using as little as 1.1 gallons of water per flush.
- Universal high efficiency toilet can be specified with 1.28 gpf [4.8 lpf], 1.6 gpf [6.0 lpf] or dual flush valves.
- Vitreous china
- Elongated front rim
- 2" fully glazed trapway
- High efficiency siphon jet flush action
- Zurn product system component compatibility and quality assurance
- Shipping Weight: 42 lbs

### Z5675 Series

#### Recommended Trim:

- Z5959SS-JUV** White, open front juvenile toilet seat less cover with stainless steel check hinge.
- Z5972-COMB** Closet bolt/wax ring kit

**Note:** To ensure system performance:  
Minimum Running Water Pressure = 25 psi.

*These dimensions and specifications are subject to change without notice.*

*Fixture dimensions meet ANSI/ASME standard A112.19.2 and CAN/CSA B45 requirements.*

Architectural/Engineering Approval

ZURN INDUSTRIES, LLC. ♦ COMMERCIAL BRASS OPERATION  
5900 ELWIN BUCHANAN DRIVE ♦ SANFORD NC 27330  
Phone: 1-800-997-3876 ♦ Fax: 919-775-3541  
www.zurn.com

In Canada: ZURN INDUSTRIES LIMITED  
3544 Nashua Drive ♦ Mississauga, Ontario L4V1L2  
Phone: 905-405-8272 Fax: 905-405-1292

### Engineering Specification: Recommended Trim:

#### Z5675-BWL

Vitreous china, 1.1 gpf [4.16 lpf] or greater high efficiency, floor mounted, children's toilet with siphon jet flushing action, 10" high elongated front rim, with 1-1/2" top spud. This bowl is designed to perform to industry standards with as little as 1.1 gallons per flush, engineered to provide optimal performance.

See Zurn One Systems for suggested packages.

The information contained in this document is subject to change without notice.  
Please contact Zurn for most up to date information.



# Z5675-BWL

TAG \_\_\_\_\_

## HET Children's Floor Mounted EcoVantage® Flush Valve Toilet

Rough-in dimensions for Z5675 Series

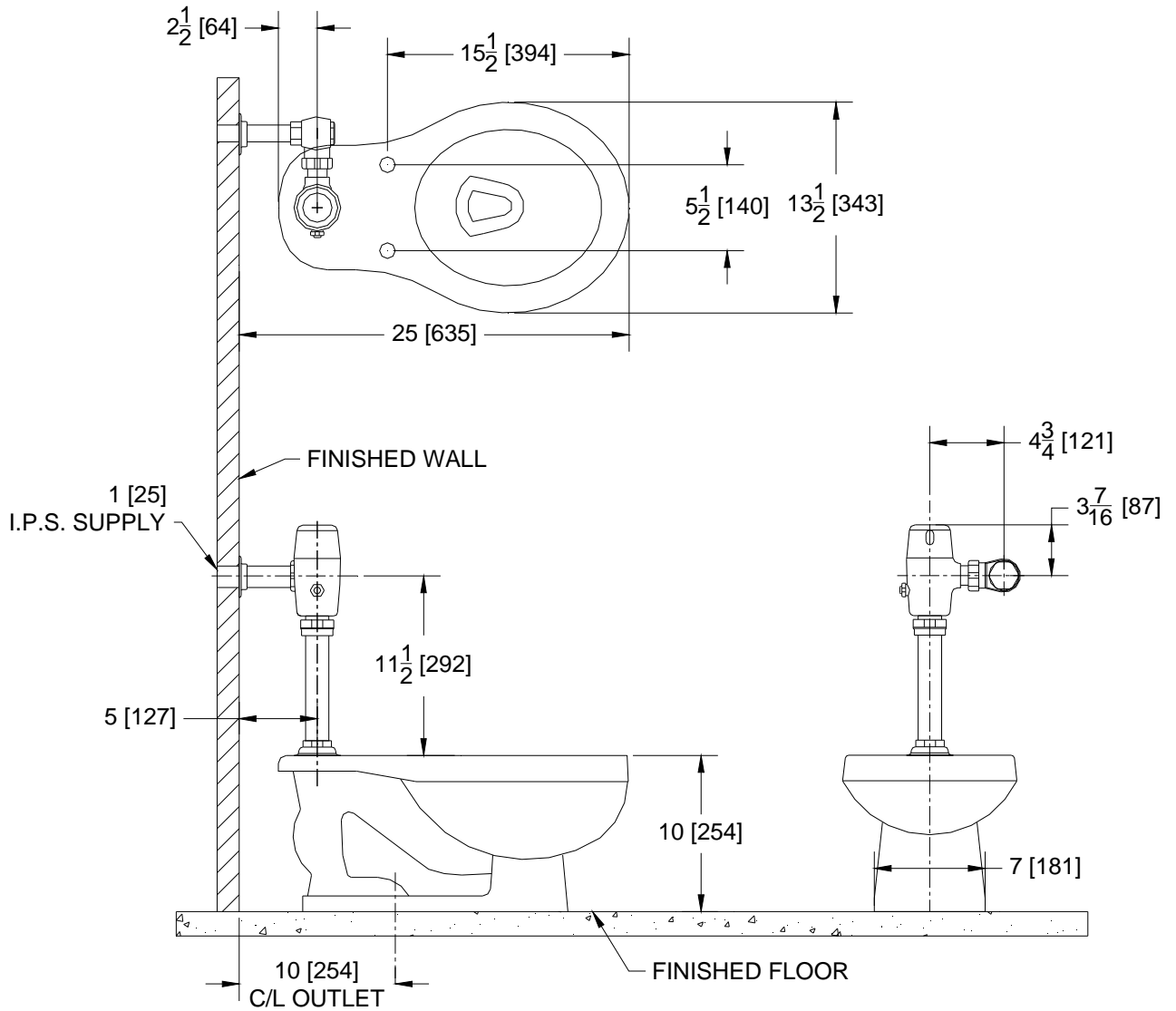

*These dimensions and specifications are subject to change without notice.*

*Fixture dimensions meet ANSI/ASME standard A112.19.2 and CAN/CSA B45 requirements.*

ZURN INDUSTRIES, LLC. ♦ COMMERCIAL BRASS OPERATION  
5900 ELWIN BUCHANAN DRIVE ♦ SANFORD NC 27330  
Phone: 1-800-997-3876 ♦ Fax: 919-775-3541  
www.zurn.com  
In Canada: ZURN INDUSTRIES LIMITED  
3544 Nashua Drive ♦ Mississauga, Ontario L4V1L2  
Phone: 905-405-8272 Fax: 905-405-1292

EcoVantage® is a registered trademark of Zurn Industries, LLC.