

7AH1AV

Upflow/Horizontal | Variable Speed | Omniguard® Coil | TXV Furnished | R-454B | 60Hz

RESIDENTIAL
PRODUCT SPECIFICATIONS

1.5 to 5 Tons
Optional Electric Heat - 5 to 20 kW



MODEL NUMBER IDENTIFICATION

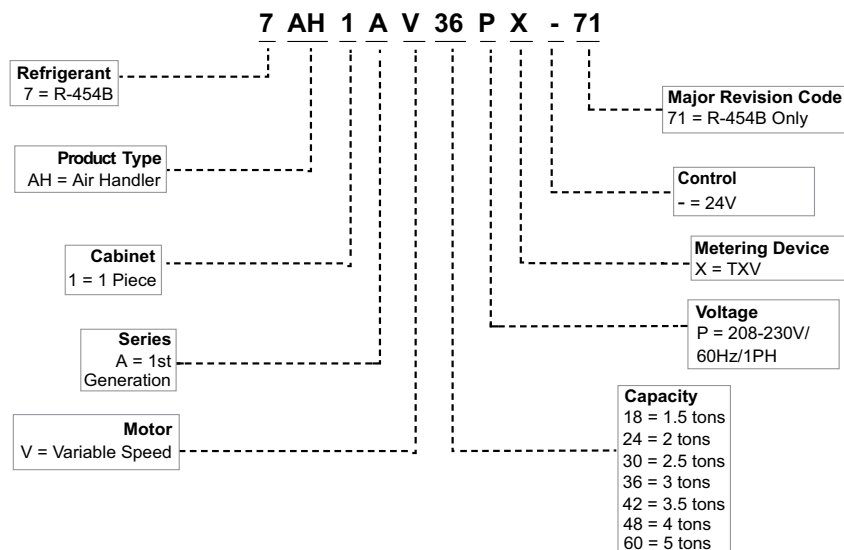

FEATURE HIGHLIGHTS

1. Omniguard® Coil
2. Mechanical or Brazed Line Set Connections
3. Check and Expansion Valve
4. Variable Speed Blower Motor
5. Heavy Gauge Steel Cabinet
6. Anti-Microbial Dual Position Drain Pans
7. Built in Filter Rack
8. Transformer and Blower Relay
9. Electric Heat (optional)

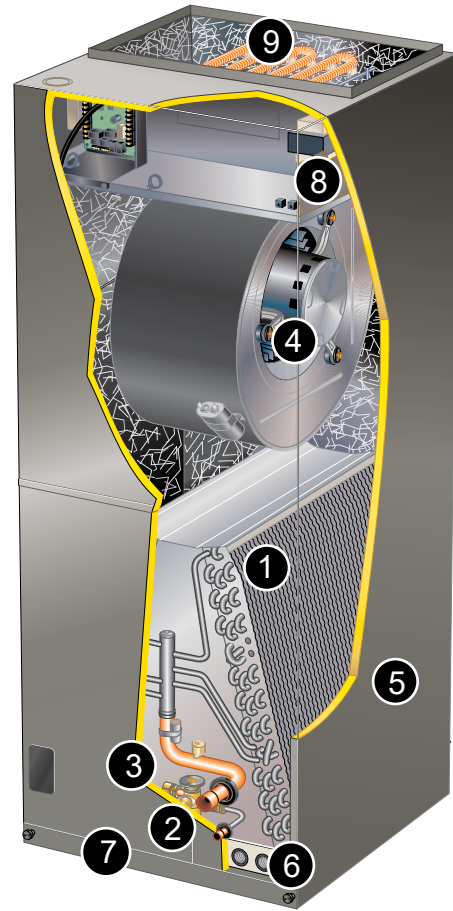

CONTENTS

Model Number Identification	1
Approvals And Warranty	3
Features.	3
Specifications	6
Electrical Data.	6
Optional Accessories - Order Separately	6
Replacement Circuit Breakers	7
Installation Clearances With Electric Heat	7
Blower Data.	8
Electric Heat Data.	15
Dimensions	20
- Unit - Upflow Position	20
- Unit - Horizontal Position	21
- Accessories	22

APPROVALS AND WARRANTY

APPROVALS

- Tested with matching air conditioners and heat pump units in accordance with AHRI Standard 210/240-2023
- AHRI Certified system match-ups and expanded ratings, visit www.alliedratings.com
- ETL Listed to US and Canadian safety standards and components within are bonded for grounding to meet safety standards for servicing required by NEC and CEC
- Optional electric heaters are ETL listed and rated in accordance with US Department of Energy (DOE) test procedures and Federal Trade Commission (FTC) labeling regulations
- Blower performance data according to unit tests conducted in air test chamber
- Approved for installation in manufactured housing and mobile homes
- ISO 9001 Registered Manufacturing Quality System

WARRANTY

10-years limited warranty on all parts, extended warranty available.

Warranty provides for a total of 10-years of limited warranty.

Coverage (Standard 5-year limited parts warranty plus an additional 5-year limited extended parts warranty).

Warranty must be registered online within 60 days of installation to qualify for 10-year coverage.

Unregistered equipment defaults to 5-year coverage.

See full warranty at www.alliedair.com for terms, conditions, and exclusions.

FEATURES

APPLICATIONS

- 1.5 to 5 ton nominal sizes
- Upflow or horizontal applications

NOTE - Downflow applications require optional conversion kit.

- Applicable to expansion valve systems in cooling applications and check and expansion valve systems in heat pump applications
- Wide-range check and expansion valve is factory installed
- Optional field installed electric heaters available in several sizes for additive heating capacity

ZONING APPLICATIONS

- Units can be used with certain zoning systems
- Zone control panel **MUST** be able to interface and communicate with the variable speed motor in the unit

REFRIGERANT SYSTEM

1

Omniguard® Coil

- Enhanced aluminum alloy tube/enhanced fin coil for superior corrosion resistance
- Aluminum tubing, hairpins, distributor and header tubes.
- Ripple-edged aluminum fins
- Twin coil construction assembled in a “A” configuration for large surface area
- Provides excellent heat transfer and low air resistance for maximum efficiency

- Precise circuiting for uniform refrigerant distribution
- Lanced fins provide maximum exposure of fin surface to air stream
- Axial grooved tubing provides superior heat transfer
- Coil thoroughly factory tested under high pressure to ensure leakproof construction

2

Mechanical or Brazed Line Set Connections

- Copper refrigerant sweat connections on both liquid and suction lines for easy brazing
- Lines extend outside of the cabinet for ease of connection
- See dimension drawings for locations

Braze-Free/Press Fitting Flexibility

- Units can accommodate braze-free or press fittings for installation versatility

3

R-454B Check and Expansion Valve

- For use with R-454B systems
- Wide range valve with Chatleff style fitting
- Factory installed on all models, internal to cabinet

FEATURES

REFRIGERANT DETECTION SYSTEM (RDS)

- Complies with UL 60335-2-40 approved standard
- Required for all systems using R-454B refrigerant
- Consists of a factory installed Refrigerant Detection System (RDS) sensor and a Refrigerant Detection System (RDS) Blower Control Board

Refrigerant Detection System (RDS) Air Handler Sensor

- Sensor ensures safe operation for systems equipped with R-454B refrigerant
- Indoor sensor will detect any R-454B refrigerant

NOTE - Sensor must be repositioned for horizontal-right, horizontal-left, and downflow applications.

Blower Control Board

- Connected to the RDS sensor
- Used as interface between indoor unit and thermostat to control system
- Ensures safe operation for systems equipped with R-454B refrigerant
- If R-454B refrigerant is detected, the refrigerant detection system will stop compressor and/or heating operation and operate the blower to reduce concentrations in the conditioned space
- Once safe levels are reached the HVAC system will resume normal operation
- Multi-color LED for system status and as an aid in troubleshooting
- Flashing LED codes for system status (Green/Blue) and diagnosing Sensor errors (Red)
- Alarm relay can trigger an external alarm if R-454B refrigerant is detected
- Zone relay opens all zone dampers (if part of a zoning system) if R-454B refrigerant is detected
- Power is disabled to thermostat to prevent demand if R-454B refrigerant is detected
- On system start-up blower will run for five minutes and any thermostat demands are disabled

NOTE - Refer to the Installation Instructions for additional information

BLOWER

4 Programmable Variable Speed Blower Motor

- High efficiency
- Maintains specified air volumes up to a maximum of 0.8 in. w.g. total external static
- Programmable operation is achieved by the use of an ECM (Electronically Commutated Motor) motor
- Allows cooling ramping profiles (field selectable) for enhanced dehumidification
- Motor accelerates and decelerates gradually, reducing start-up and shut-down sound
- Leadless blower motor features simple plug-in connections

- Motor is controlled by BDC3 Electronic Blower Control that allows blower to operate at two of eight air volumes or speeds available
- Blower speeds may be field selected on blower control depending on size of air handler and air volume desired

Blower Assembly

- Each blower is statically and dynamically balanced as an assembly before installation in the unit
- Blower motor is resiliently mounted to blower assembly
- Blower slides out of cabinet for servicing

CONTROLS

BDC3 Electronic Blower Control

- Controls evaporator humidity by controlling blower and compressor staging on two-stage outdoor units
- Two Stages - HEAT and COOL (with four different air volume selections for each) are made by simple jumper pins on board
- ADJUST jumper pin allows approximately 10% higher, normal or 10% lower motor speed selection within HEAT and COOL speeds selected for fine tuning air volume
- DELAY jumper pin allows selection of four different blower motor de-humidification profiles during cooling mode:
 - Option 1 - Motor runs at 100% of capacity until demand met. Once demand is met, motor ramps down to stop.
 - Option 2 - Motor runs at 100% until demand is met. Once demand is satisfied, motor runs at 100% for 60 seconds then ramps down to stop
 - Option 3 - Motor runs at 82% of capacity for approximately 7-1/2 minutes, then 100% capacity (if needed) until demand is satisfied. Once demand is met, motor ramps down to stop
 - Option 4 - Motor runs at 50% capacity for 30 seconds, then 82% capacity for approximately 7-1/2 minutes. If demand is not satisfied, motor runs at 100% capacity until demand is met. Once demand is met, motor runs at 50% capacity for 30 seconds, then ramps down to stop
- Two diagnostic indicator lights, "CFM" and "RUN" assist in servicing
- Control is factory installed in the unit control box

CABINET

- 5** • Constructed of heavy gauge galvanized steel
- Pre-painted cabinet finish
- Completely insulated with foil faced fiberglass insulation
- Removable panels provide complete service access
- Filter access door for easy filter replacement
- Thumbscrews hold filter door in place
- Electrical inlets provided in sides and top of cabinet
- See dimension drawing for locations
- Plugs in cabinet for drain connections for upflow (left and right) and horizontal applications
- See dimension drawing

FEATURES

Low Leakage Cabinet

- All models have less than 2% air leakage and meet ANSI/ASHRAE Standard 193-2010 "Method of Test for Determining the Air Tightness of HVAC Equipment"

Upflow/Horizontal Capability (Optional Downflow)

- Shipped for upflow and horizontal right-hand discharge
- May be field converted to horizontal left-hand air discharge by repositioning horizontal drain pan
- Optional downflow kit required for field conversion

6 Anti-Microbial Dual Position Drain Pans

- Anti-Microbial additive resists growth of mold and mildew on drain pan which improves indoor air quality and reduces drain line blockage
- Drain pans designed for upflow or horizontal applications
- Deep, corrosion resistant high temperature engineered polymer drain pans have dual pipe drains
- See dimension drawing

7 FILTER

- Disposable 1 inch filter is furnished
- Filter rack furnished in cabinet for easy filter installation
- See Specifications tables for filter sizes

8 Transformer

- 24 volt transformer with in-line fuse
- Factory installed in the unit control box

CABINET (Continued)

Optional Accessories

Downflow Conversion Kit

- Required for field conversion to downflow position
- Kit consists of insulated downflow drain pan, insulated drain pan drip shields, coil drip shields, seal plates and support brackets for repositioning coil and drain pan

Horizontal Support Frame Kit

- Provides support of unit in horizontal applications
- Consists of (2) 1 x 1-1/2 x 32-5/8 in. and (2) 1 x 3 x 53-7/8 in. painted heavy gauge cold rolled steel support channels with assembly and suspending holes
- Bolts and nuts furnished for field assembly
- Suspending rods must be field provided

Side Return Unit Stand (Upflow Only)

- Raises unit 16 in. above floor for side return air duct connection
- Eliminates need for wooden platform construction
- All aluminum construction
- Two adjustable frames fit all sizes

Wall Hanging Bracket Kit (Upflow Only)

- Allows unit to be hung on wall at any height
- Consists of heavy-gauge steel support brackets (one for air handler, one for wall mount)
- Screws furnished for fastening one bracket to unit
- Bolts for fastening one bracket to wall are field provided

High Performance Economizer (Commercial Applications Only)

- Designed for applications requiring outdoor air to be utilized in a commercial HVAC system

- Allows the entry of fresh outdoor air for free cooling, reducing the requirement for mechanical cooling
- Heavy gauge galvanized steel cabinet lined with thick fiberglass insulation
- Mixed air sensor, outdoor air sensor and 24VAC transformer furnished
- Approved for California Title 24 building standards
- ASHRAE 90.1-2010 compliant
- See separate Product Specifications document for additional information and available control and sensor options

9 OPTIONAL ELECTRIC HEAT

- ETL listed
- Field install internal to unit cabinet
- Available in several kW sizes
- See Electric Heat tables
- Helix wound nichrome heating elements exposed directly in air stream resulting in instant heat transfer, low element temperatures and long service life
- Each element equipped with accurately located limit control with fixed temperature off setting and automatic reset
- Thermal sequencer relay brings elements on and off line, in sequence and equal increments, with time delay between each
- Initiates and terminates blower operation
- Heating control relay(s) furnished as standard
- Factory assembled with controls installed and wired
- Electric heat control wiring plugs into mating connector on air handler unit

Circuit Breaker (CB) Models

- All "CB" model heaters are equipped with circuit breakers for overload and short circuit protection
- Factory wired and mounted on electric heat unit
- Current sensitive and temperature actuated
- Manual reset
- Flexible plastic circuit breaker cover protects circuit breaker in areas with high humidity or unconditioned areas to prevent nuisance tripping
- Circuit breakers qualify as disconnect means at unit in many areas, eliminate the need for field provided disconnect
- Consult local electrical code in your area

Optional Accessories

Single-Point Power Source Control Box

- Control Box may be used with optional electric heat when single power supply is connected to multi-circuit electric heat
- Field installs external to the unit cabinet on either side or top
- Constructed of heavy gauge steel, baked enamel finish, pre-punched mounting holes, electrical inlet knockouts, and terminal strip
- Removeable cover provides easy access
- Dimensions (H x W x D) - 7 x 7 x 4 in.

SPECIFICATIONS

Size		018	024	030	036
Nominal Tonnage		1.5	2	2.5	3
Refrigerant Type		R-454B	R-454B	R-454B	R-454B
Connections	Liquid line (OD) sweat - in.	3/8	3/8	3/8	3/8
	Suction line (OD) sweat - in.	3/4	3/4	3/4	7/8
	Condensate drain (FPT) - in.	(2) 3/4	(2) 3/4	(2) 3/4	(2) 3/4
Indoor Coil	Net face area - ft. ²	3.30	3.77	4.72	5.66
	Tube diameter - in.	3/8	3/8	3/8	3/8
	Rows	3	3	3	3
	Fins - in.	15	15	15	15
Blower	HP	1/2	1/2	1/2	1/2
	Wheel nominal diameter x width - in.	9 x 6	9 x 6	10 x 8	10 x 8
	Air volume range - cfm	320 - 1150	280 - 1120	411 - 1340	545 - 1530
¹ Filters	Size - in.	15 x 20 x 1	15 x 20 x 1	15 x 20 x 1	18 x 20 x 1
Shipping Data - lbs.		129	136	143	169

ELECTRICAL DATA

Line voltage data (Volts-Phase-Hz)	208/230-1-60	208/230-1-60	208/230-1-60	208/230-1-60
² Maximum overcurrent protection (MOCP) amps (unit)	15	15	15	15
³ Minimum circuit ampacity (MCA) (unit)	4.9	4.9	4.9	4.9
Blower Motor Full Load Amps	3.9	3.9	3.9	3.9

SPECIFICATIONS

Size		042	048	060
Nominal Tonnage		3.5	4	5
Refrigerant Type		R-454B	R-454B	R-454B
Connections	Liquid line (OD) sweat - in.	3/8	3/8	3/8
	Suction line (OD) sweat - in.	7/8	7/8	7/8
	Condensate drain (FPT) - in.	(2) 3/4	(2) 3/4	(2) 3/4
Indoor Coil	Net face area - ft. ²	5.66	6.13	7.08
	Tube diameter - in.	3/8	3/8	3/8
	Rows	3	3	3
	Fins - in.	15	15	15
Blower	HP	1	1	1
	Wheel nominal diameter x width - in.	10 x 8	12 x 10	12 x 10
	Air volume range - cfm	670 - 1810	790 - 2185	895 - 2190
¹ Filters	Size - in.	18 x 20 x 1	18 x 20 x 1	18 x 20 x 1
Shipping Data - lbs.		169	179	190

ELECTRICAL DATA

Line voltage data (Volts-Phase-Hz)	208/230-1-60	208/230-1-60	208/230-1-60
² Maximum overcurrent protection (MOCP) amps (unit)	15	15	15
³ Minimum circuit ampacity (MCA) (unit)	6.5	8.6	8.6
Blower Motor Full Load Amps	6.9	6.9	6.9

¹ Disposable filter.

² HACR type circuit breaker or fuse.

³ Refer to National or Canadian Electrical Code manual to determine wire, fuse and disconnect size requirements. Use wires suitable for at least 167°F.

OPTIONAL ACCESSORIES - ORDER SEPARATELY

Description	018, 024, 030	036, 042, 048, 060
Downflow Conversion Kit	Y9658	Y9659
Electric Heat	See Electric Heat Data Tables on page 15	
Horizontal Support Frame Kit	56J18	56J18
Side Return Unit Stand (Upflow Only)	45K32	45K32
Single-Point Power Source Control Box (for Electric Heat)	21H39	21H39
Wall Hanging Bracket Kit (Upflow Only)	45K30	45K30
High Performance Economizer (Commercial Only)	10U53	10U53

REPLACEMENT CIRCUIT BREAKERS

Voltage	Description	Order Number
208/240V - 1 Phase	25 amp, 2 pole	41K13
	30 amp, 2 pole	17K70
	35 amp, 2 pole	72K07
	40 amp, 2 pole	49K14
	45 amp, 2 pole	17K71
	50 amp, 2 pole	41K12
	60 amp, 2 pole	17K72

INSTALLATION CLEARANCES WITH ELECTRIC HEAT

Cabinet	0 inch (0 mm)
To Plenum	0 inch (0 mm)
To Outlet Duct	0 inch (0 mm)
Floor	0 inch (0 mm)
Service / Maintenance	See Note #1

¹ Front service access - 24 inches (610 mm) minimum.

NOTE - If cabinet depth is more than 24 inches (610 mm), allow a minimum of the cabinet depth plus 2 inches (51 mm).

BLOWER DATA

7AH1AV-018 BLOWER PERFORMANCE

0 through 0.80 in. w.g. External Static Pressure Range

"ADJUST" Jumper Setting	Jumper Speed Positions											
	"HEAT" Speed				First Stage "COOL" Speed				Second Stage "COOL" Speed			
	1	2	3	4	1	2	3	4	1	2	3	4
	cfm	cfm	cfm	cfm	cfm	cfm	cfm	cfm	cfm	cfm	cfm	cfm
+	500	705	925	1150	365	520	665	810	500	705	925	1150
NORM	465	650	850	1050	350	485	610	740	465	650	850	1050
-	420	600	760	950	320	425	560	680	420	600	760	950

NOTES - All air data measured external to unit with dry coil and 1 inch non-pleated air filter in place. Electric heaters have no appreciable air resistance.

First stage cooling air volume is 70% of COOL speed setting. Continuous blower speed is approximately 50% of COOL speed setting.

Allied LZSV Variable Zoning System applications - minimum blower speed is 250 cfm.

7AH1AV-018 BLOWER MOTOR WATTS

AT "+" (Plus) SETTING ("Adjust" Jumper at "+" Setting)

Jumper Speed Positions		Motor Watts @ Various External Static Pressures - in. wg.							
		0.1	0.2	0.3	0.4	0.5	0.6	0.7	0.8
"HEAT" Speed	Tap 1	46	61	74	86	99	111	124	138
	Tap 2	97	115	132	145	162	178	196	213
	Tap 3	185	205	229	245	268	282	300	316
	Tap 4	340	366	392	417	439	459	488	488
First Stage "COOL" Speed	Tap 1	30	41	51	59	69	81	92	106
	Tap 2	50	66	80	90	105	118	126	142
	Tap 3	87	106	116	135	148	167	178	192
	Tap 4	141	161	181	201	215	228	247	262
Second Stage "COOL" Speed	Tap 1	46	61	74	86	99	111	124	138
	Tap 2	97	115	132	145	162	178	196	213
	Tap 3	185	205	229	245	268	282	300	316
	Tap 4	340	366	392	417	439	459	488	488

AT "NORM" SETTING ("Adjust" Jumper at NORM Setting)

Jumper Speed Positions		Motor Watts @ Various External Static Pressures - in. wg.							
		0.1	0.2	0.3	0.4	0.5	0.6	0.7	0.8
"HEAT" Speed	Tap 1	40	55	66	80	93	101	115	128
	Tap 2	82	100	113	125	144	157	176	183
	Tap 3	146	170	191	207	224	238	259	276
	Tap 4	259	290	314	330	352	369	391	415
First Stage "COOL" Speed	Tap 1	28	37	46	58	67	79	89	102
	Tap 2	45	59	70	85	96	107	119	133
	Tap 3	74	88	102	120	132	145	161	171
	Tap 4	115	131	147	162	185	195	210	229
Second Stage "COOL" Speed	Tap 1	40	55	66	80	93	101	115	128
	Tap 2	82	100	113	125	144	157	176	183
	Tap 3	146	170	191	207	224	238	259	276
	Tap 4	259	290	314	330	352	369	391	415

AT "-" (Minus) SETTING ("Adjust" Jumper at "-" Setting)

Jumper Speed Positions		Motor Watts @ Various External Static Pressures - in. wg.							
		0.1	0.2	0.3	0.4	0.5	0.6	0.7	0.8
"HEAT" Speed	Tap 1	33	43	56	65	77	88	96	112
	Tap 2	65	80	93	113	126	140	151	164
	Tap 3	119	140	153	169	185	206	220	236
	Tap 4	195	219	237	261	281	296	320	338
First Stage "COOL" Speed	Tap 1	23	35	43	52	63	73	85	96
	Tap 2	37	45	54	70	76	86	99	110
	Tap 3	59	73	86	102	113	128	140	152
	Tap 4	88	102	119	137	154	165	185	201
Second Stage "COOL" Speed	Tap 1	33	43	56	65	77	88	96	112
	Tap 2	65	80	93	113	126	140	151	164
	Tap 3	119	140	153	169	185	206	220	236
	Tap 4	195	219	237	261	281	296	320	338

BLOWER DATA

7AH1AV-024 BLOWER PERFORMANCE

0 through 0.80 in. w.g. External Static Pressure Range

"ADJUST" Jumper Setting	Jumper Speed Positions											
	"HEAT" Speed				First Stage "COOL" Speed				Second Stage "COOL" Speed			
	1	2	3	4	1	2	3	4	1	2	3	4
	cfm	cfm	cfm	cfm	cfm	cfm	cfm	cfm	cfm	cfm	cfm	cfm
+	450	670	900	1120	340	450	650	770	450	670	900	1120
NORM	420	620	820	1050	300	400	600	700	420	620	820	1050
-	390	570	750	915	280	390	500	650	390	570	750	915

NOTES - All air data measured external to unit with dry coil and 1 inch non-pleated air filter in place. Electric heaters have no appreciable air resistance.

First stage cooling air volume is 70% of COOL speed setting. Continuous blower speed is approximately 50% of COOL speed setting.

Allied LZSV Variable Zoning System applications - minimum blower speed is 250 cfm.

7AH1AV-024 BLOWER MOTOR WATTS

AT "+" (Plus) SETTING ("Adjust" Jumper at "+" Setting)

Jumper Speed Positions		Motor Watts @ Various External Static Pressures - in. wg.							
		0.1	0.2	0.3	0.4	0.5	0.6	0.7	0.8
"HEAT" Speed	Tap 1	40	50	60	74	86	95	112	124
	Tap 2	82	100	116	136	151	163	185	197
	Tap 3	173	190	213	236	257	283	300	316
	Tap 4	290	318	339	363	379	407	447	463
First Stage "COOL" Speed	Tap 1	27	37	46	57	68	76	88	104
	Tap 2	41	54	62	75	87	97	108	121
	Tap 3	75	94	109	127	145	161	173	191
	Tap 4	113	133	146	168	189	205	222	244
Second Stage "COOL" Speed	Tap 1	40	50	60	74	86	95	112	124
	Tap 2	82	100	116	136	151	163	185	197
	Tap 3	173	190	213	236	257	283	300	316
	Tap 4	290	318	339	363	379	407	447	463

AT "NORM" SETTING ("Adjust" Jumper at NORM Setting)

Jumper Speed Positions		Motor Watts @ Various External Static Pressures - in. wg.							
		0.1	0.2	0.3	0.4	0.5	0.6	0.7	0.8
"HEAT" Speed	Tap 1	33	45	57	68	78	89	101	115
	Tap 2	64	81	96	113	132	145	159	179
	Tap 3	133	152	172	190	211	231	252	270
	Tap 4	253	278	307	325	348	374	397	415
First Stage "COOL" Speed	Tap 1	26	36	39	52	62	73	93	102
	Tap 2	37	45	57	66	76	90	100	113
	Tap 3	62	80	94	108	123	135	152	171
	Tap 4	88	108	128	145	162	181	195	214
Second Stage "COOL" Speed	Tap 1	33	45	57	68	78	89	101	115
	Tap 2	64	81	96	113	132	145	159	179
	Tap 3	133	152	172	190	211	231	252	270
	Tap 4	253	278	307	325	348	374	397	415

AT "-" (Minus) SETTING ("Adjust" Jumper at "-" Setting)

Jumper Speed Positions		Motor Watts @ Various External Static Pressures - in. wg.							
		0.1	0.2	0.3	0.4	0.5	0.6	0.7	0.8
"HEAT" Speed	Tap 1	30	43	54	62	73	84	97	109
	Tap 2	52	71	87	99	117	128	145	157
	Tap 3	100	118	138	161	179	193	204	228
	Tap 4	167	185	206	230	256	280	295	316
First Stage "COOL" Speed	Tap 1	23	29	42	48	60	75	88	93
	Tap 2	31	39	54	62	76	86	96	105
	Tap 3	46	56	70	84	93	107	115	133
	Tap 4	72	87	105	121	141	158	175	188
Second Stage "COOL" Speed	Tap 1	30	43	54	62	73	84	97	109
	Tap 2	52	71	87	99	117	128	145	157
	Tap 3	100	118	138	161	179	193	204	228
	Tap 4	167	185	206	230	256	280	295	316

BLOWER DATA

7AH1AV-030 BLOWER PERFORMANCE

0 through 0.80 in. w.g. External Static Pressure Range

"ADJUST" Jumper Setting	Jumper Speed Positions											
	"HEAT" Speed				First Stage "COOL" Speed				Second Stage "COOL" Speed			
	1	2	3	4	1	2	3	4	1	2	3	4
	cfm	cfm	cfm	cfm	cfm	cfm	cfm	cfm	cfm	cfm	cfm	cfm
+	680	885	1115	1340	490	635	770	930	680	885	1115	1340
NORM	620	810	1020	1220	440	575	715	845	620	810	1020	1220
-	550	725	905	1100	411	530	645	755	550	725	905	1100

NOTES - All air data measured external to unit with dry coil and 1 inch non-pleated air filter in place. Electric heaters have no appreciable air resistance.

First stage cooling air volume is 70% of COOL speed setting. Continuous blower speed is approximately 50% of COOL speed setting.

Allied LZSV Variable Zoning System applications - minimum blower speed is 250 cfm.

7AH1AV-030 BLOWER MOTOR WATTS

AT "+" (Plus) SETTING ("Adjust" Jumper at "+" Setting)

Jumper Speed Positions		Motor Watts @ Various External Static Pressures - in. wg.							
		0.1	0.2	0.3	0.4	0.5	0.6	0.7	0.8
"HEAT" Speed	Tap 1	64	81	108	136	153	201	210	246
	Tap 2	120	136	162	182	198	221	246	286
	Tap 3	210	231	259	280	303	323	348	376
	Tap 4	367	392	420	452	486	506	510	520
First Stage "COOL" Speed	Tap 1	32	52	70	88	96	120	148	172
	Tap 2	50	72	91	115	143	177	200	215
	Tap 3	87	102	120	142	170	195	227	243
	Tap 4	128	151	176	196	213	239	259	294
Second Stage "COOL" Speed	Tap 1	64	81	108	136	153	201	210	246
	Tap 2	120	136	162	182	198	221	246	286
	Tap 3	210	231	259	280	303	323	348	376
	Tap 4	367	392	420	452	486	506	510	520

AT "NORM" SETTING ("Adjust" Jumper at NORM Setting)

Jumper Speed Positions		Motor Watts @ Various External Static Pressures - in. wg.							
		0.1	0.2	0.3	0.4	0.5	0.6	0.7	0.8
"HEAT" Speed	Tap 1	55	70	94	118	148	171	198	209
	Tap 2	91	113	132	151	177	201	222	242
	Tap 3	167	187	209	230	252	279	304	331
	Tap 4	268	304	329	354	380	403	431	451
First Stage "COOL" Speed	Tap 1	30	47	64	73	95	113	121	133
	Tap 2	46	67	87	119	140	151	163	187
	Tap 3	75	91	113	138	164	196	228	267
	Tap 4	104	125	142	158	187	215	244	265
Second Stage "COOL" Speed	Tap 1	55	70	94	118	148	171	198	209
	Tap 2	91	113	132	151	177	201	222	242
	Tap 3	167	187	209	230	252	279	304	331
	Tap 4	268	304	329	354	380	403	431	451

AT "-" (Minus) SETTING ("Adjust" Jumper at "-" Setting)

Jumper Speed Positions		Motor Watts @ Various External Static Pressures - in. wg.							
		0.1	0.2	0.3	0.4	0.5	0.6	0.7	0.8
"HEAT" Speed	Tap 1	47	59	78	108	126	150	158	189
	Tap 2	72	89	111	130	157	193	214	241
	Tap 3	128	144	162	180	200	216	254	284
	Tap 4	194	223	247	268	292	317	347	368
First Stage "COOL" Speed	Tap 1	30	42	56	68	86	104	119	132
	Tap 2	45	57	84	97	113	132	157	181
	Tap 3	67	75	99	129	161	184	208	247
	Tap 4	85	101	120	138	163	197	234	253
Second Stage "COOL" Speed	Tap 1	47	59	78	108	126	150	158	189
	Tap 2	72	89	111	130	157	193	214	241
	Tap 3	128	144	162	180	200	216	254	284
	Tap 4	194	223	247	268	292	317	347	368

BLOWER DATA

7AH1AV-036 BLOWER PERFORMANCE

0 through 0.80 in. w.g. External Static Pressure Range

"ADJUST" Jumper Setting	Jumper Speed Positions											
	"HEAT" Speed				First Stage "COOL" Speed				Second Stage "COOL" Speed			
	1	2	3	4	1	2	3	4	1	2	3	4
	cfm	cfm	cfm	cfm	cfm	cfm	cfm	cfm	cfm	cfm	cfm	cfm
+	930	1155	1390	1530	640	815	970	1150	930	1155	1390	1530
NORM	830	1050	1260	1450	590	725	875	1025	830	1050	1260	1450
-	740	940	1135	1330	545	650	780	910	740	940	1135	1330

NOTES - All air data measured external to unit with dry coil and 1 inch non-pleated air filter in place. Electric heaters have no appreciable air resistance.

First stage cooling air volume is 70% of COOL speed setting. Continuous blower speed is approximately 50% of COOL speed setting.

Allied LZSV Variable Zoning System applications - minimum blower speed is 250 cfm.

7AH1AV-036 BLOWER MOTOR WATTS

AT "+" (Plus) SETTING ("Adjust" Jumper at "+" Setting)

Jumper Speed Positions		Motor Watts @ Various External Static Pressures - in. wg.							
		0.1	0.2	0.3	0.4	0.5	0.6	0.7	0.8
"HEAT" Speed	Tap 1	111	132	152	193	226	246	271	282
	Tap 2	188	215	242	271	295	327	391	412
	Tap 3	298	325	361	395	433	474	491	515
	Tap 4	464	503	516	537	526	527	529	522
First Stage "COOL" Speed	Tap 1	53	78	98	112	135	151	173	192
	Tap 2	78	101	118	149	173	191	217	237
	Tap 3	115	136	162	185	237	265	284	308
	Tap 4	166	196	228	252	284	303	364	399
Second Stage "COOL" Speed	Tap 1	111	132	152	193	226	246	271	282
	Tap 2	188	215	242	271	295	327	391	412
	Tap 3	298	325	361	395	433	474	491	515
	Tap 4	464	503	516	537	526	527	529	522

AT "NORM" SETTING ("Adjust" Jumper at NORM Setting)

Jumper Speed Positions		Motor Watts @ Various External Static Pressures - in. wg.							
		0.1	0.2	0.3	0.4	0.5	0.6	0.7	0.8
"HEAT" Speed	Tap 1	79	102	128	170	189	210	225	254
	Tap 2	138	165	191	219	243	300	328	347
	Tap 3	225	249	287	315	351	377	407	429
	Tap 4	342	384	425	456	510	531	533	525
First Stage "COOL" Speed	Tap 1	41	69	80	100	115	141	159	176
	Tap 2	64	80	114	136	155	169	197	214
	Tap 3	241	219	202	155	145	116	94	85
	Tap 4	319	296	258	211	189	163	138	123
Second Stage "COOL" Speed	Tap 1	79	102	128	170	189	210	225	254
	Tap 2	138	165	191	219	243	300	328	347
	Tap 3	225	249	287	315	351	377	407	429
	Tap 4	342	384	425	456	510	531	533	525

AT "-" (Minus) SETTING ("Adjust" Jumper at "-" Setting)

Jumper Speed Positions		Motor Watts @ Various External Static Pressures - in. wg.							
		0.1	0.2	0.3	0.4	0.5	0.6	0.7	0.8
"HEAT" Speed	Tap 1	64	81	119	142	161	184	194	219
	Tap 2	111	131	151	174	221	255	268	293
	Tap 3	168	199	222	248	287	304	359	396
	Tap 4	249	293	331	340	386	410	443	475
First Stage "COOL" Speed	Tap 1	38	59	79	90	107	121	139	170
	Tap 2	49	73	105	112	131	151	162	184
	Tap 3	69	90	122	149	170	197	207	229
	Tap 4	105	130	147	172	219	242	262	278
Second Stage "COOL" Speed	Tap 1	64	81	119	142	161	184	194	219
	Tap 2	111	131	151	174	221	255	268	293
	Tap 3	168	199	222	248	287	304	359	396
	Tap 4	249	293	331	340	386	410	443	475

BLOWER DATA

7AH1AV-042 BLOWER PERFORMANCE

0 through 0.80 in. w.g. External Static Pressure Range

"ADJUST" Jumper Setting	Jumper Speed Positions											
	"HEAT" Speed				First Stage "COOL" Speed				Second Stage "COOL" Speed			
	1	2	3	4	1	2	3	4	1	2	3	4
	cfm	cfm	cfm	cfm	cfm	cfm	cfm	cfm	cfm	cfm	cfm	cfm
+	1130	1370	1575	1810	780	945	1110	1275	1130	1370	1575	1810
NORM	1020	1255	1440	1650	710	860	1000	1160	1020	1255	1440	1650
-	920	1135	1300	1490	670	780	910	1040	920	1135	1300	1490

NOTES - All air data measured external to unit with dry coil and 1 inch non-pleated air filter in place. Electric heaters have no appreciable air resistance.

First stage cooling air volume is 70% of COOL speed setting. Continuous blower speed is approximately 50% of COOL speed setting.

Allied LZSV Variable Zoning System applications - minimum blower speed is 450 cfm.

7AH1AV-042 BLOWER MOTOR WATTS

AT "+" (Plus) SETTING ("Adjust" Jumper at "+" Setting)

Jumper Speed Positions		Motor Watts @ Various External Static Pressures - in. wg.							
		0.1	0.2	0.3	0.4	0.5	0.6	0.7	0.8
"HEAT" Speed	Tap 1	148	175	198	227	258	275	312	364
	Tap 2	239	268	295	323	351	375	409	437
	Tap 3	338	375	411	437	470	507	537	563
	Tap 4	504	531	578	614	657	687	716	763
First Stage "COOL" Speed	Tap 1	67	91	115	143	165	185	202	223
	Tap 2	101	127	145	175	213	241	251	277
	Tap 3	140	164	196	215	250	265	299	345
	Tap 4	190	229	245	285	303	324	363	398
Second Stage "COOL" Speed	Tap 1	148	175	198	227	258	275	312	364
	Tap 2	239	268	295	323	351	375	409	437
	Tap 3	338	375	411	437	470	507	537	563
	Tap 4	504	531	578	614	657	687	716	763

AT "NORM" SETTING ("Adjust" Jumper at NORM Setting)

Jumper Speed Positions		Motor Watts @ Various External Static Pressures - in. wg.							
		0.1	0.2	0.3	0.4	0.5	0.6	0.7	0.8
"HEAT" Speed	Tap 1	116	146	168	196	221	250	286	305
	Tap 2	188	215	243	266	295	319	348	383
	Tap 3	270	300	327	353	384	417	450	474
	Tap 4	375	416	459	500	517	556	588	618
First Stage "COOL" Speed	Tap 1	57	78	107	134	151	171	192	225
	Tap 2	85	111	135	158	197	213	226	246
	Tap 3	118	138	163	186	219	254	291	305
	Tap 4	170	198	217	247	267	295	328	380
Second Stage "COOL" Speed	Tap 1	116	146	168	196	221	250	286	305
	Tap 2	188	215	243	266	295	319	348	383
	Tap 3	270	300	327	353	384	417	450	474
	Tap 4	375	416	459	500	517	556	588	618

AT "-" (Minus) SETTING ("Adjust" Jumper at "-" Setting)

Jumper Speed Positions		Motor Watts @ Various External Static Pressures - in. wg.							
		0.1	0.2	0.3	0.4	0.5	0.6	0.7	0.8
"HEAT" Speed	Tap 1	96	119	138	162	191	227	247	266
	Tap 2	153	171	200	226	249	286	303	348
	Tap 3	204	237	259	286	319	336	371	401
	Tap 4	282	312	353	384	417	441	468	503
First Stage "COOL" Speed	Tap 1	56	74	98	121	131	169	178	200
	Tap 2	79	93	115	140	165	188	199	218
	Tap 3	98	117	138	170	196	228	250	260
	Tap 4	126	148	175	194	222	254	300	322
Second Stage "COOL" Speed	Tap 1	96	119	138	162	191	227	247	266
	Tap 2	153	171	200	226	249	286	303	348
	Tap 3	204	237	259	286	319	336	371	401
	Tap 4	282	312	353	384	417	441	468	503

BLOWER DATA

-048 BLOWER PERFORMANCE

0 through 0.80 in. w.g. External Static Pressure Range

"ADJUST" Jumper Setting	Jumper Speed Positions											
	"HEAT" Speed				First Stage "COOL" Speed				Second Stage "COOL" Speed			
	1	2	3	4	1	2	3	4	1	2	3	4
	cfm	cfm	cfm	cfm	cfm	cfm	cfm	cfm	cfm	cfm	cfm	cfm
+	1375	1600	1820	2185	960	1125	1285	1620	1375	1600	1820	2185
NORM	1260	1455	1655	2085	885	1035	1185	1475	1260	1455	1655	2085
-	1125	1310	1490	1885	790	925	1060	1330	1125	1310	1490	1885

NOTES - All air data measured external to unit with dry coil and 1 inch non-pleated air filter in place. Electric heaters have no appreciable air resistance.

First stage cooling air volume is 70% of COOL speed setting. Continuous blower speed is approximately 50% of COOL speed setting.

Allied LZSV Variable Zoning System applications - minimum blower speed is 450 cfm.

7AH1AV-048 BLOWER MOTOR WATTS

AT "+" (Plus) SETTING ("Adjust" Jumper at "+" Setting)

Jumper Speed Positions		Motor Watts @ Various External Static Pressures - in. wg.							
		0.1	0.2	0.3	0.4	0.5	0.6	0.7	0.8
"HEAT" Speed	Tap 1	221	244	277	308	345	372	406	449
	Tap 2	325	363	403	448	478	517	549	578
	Tap 3	465	502	550	592	637	671	711	755
	Tap 4	922	985	1000	1006	996	991	996	989
First Stage "COOL" Speed	Tap 1	94	129	152	179	206	247	265	288
	Tap 2	135	168	190	220	247	275	313	367
	Tap 3	176	213	241	270	292	344	366	405
	Tap 4	330	368	405	439	478	515	542	576
Second Stage "COOL" Speed	Tap 1	221	244	277	308	345	372	406	449
	Tap 2	325	363	403	448	478	517	549	578
	Tap 3	465	502	550	592	637	671	711	755
	Tap 4	922	985	1000	1006	996	991	996	989

AT "NORM" SETTING ("Adjust" Jumper at NORM Setting)

Jumper Speed Positions		Motor Watts @ Various External Static Pressures - in. wg.							
		0.1	0.2	0.3	0.4	0.5	0.6	0.7	0.8
"HEAT" Speed	Tap 1	180	208	240	275	296	333	362	410
	Tap 2	252	287	311	346	380	407	456	484
	Tap 3	347	392	434	457	507	534	579	615
	Tap 4	696	749	797	841	881	927	972	999
First Stage "COOL" Speed	Tap 1	77	102	128	153	185	210	231	247
	Tap 2	111	133	164	188	219	251	279	304
	Tap 3	144	175	206	233	262	285	325	352
	Tap 4	251	283	317	364	382	419	447	482
Second Stage "COOL" Speed	Tap 1	180	208	240	275	296	333	362	410
	Tap 2	252	287	311	346	380	407	456	484
	Tap 3	347	392	434	457	507	534	579	615
	Tap 4	696	749	797	841	881	927	972	999

AT "-" (Minus) SETTING ("Adjust" Jumper at "-" Setting)

Jumper Speed Positions		Motor Watts @ Various External Static Pressures - in. wg.							
		0.1	0.2	0.3	0.4	0.5	0.6	0.7	0.8
"HEAT" Speed	Tap 1	133	164	192	221	253	280	318	352
	Tap 2	203	224	270	291	317	371	403	430
	Tap 3	273	309	343	376	413	441	471	522
	Tap 4	518	573	610	667	694	732	776	821
First Stage "COOL" Speed	Tap 1	61	87	116	141	168	186	204	222
	Tap 2	85	109	135	166	197	222	249	270
	Tap 3	115	142	168	199	220	253	287	330
	Tap 4	194	227	253	288	320	359	388	415
Second Stage "COOL" Speed	Tap 1	133	164	192	221	253	280	318	352
	Tap 2	203	224	270	291	317	371	403	430
	Tap 3	273	309	343	376	413	441	471	522
	Tap 4	518	573	610	667	694	732	776	821

BLOWER DATA

7AH1AV-060 BLOWER PERFORMANCE

0 through 0.80 in. w.g. External Static Pressure Range

"ADJUST" Jumper Setting	Jumper Speed Positions											
	"HEAT" Speed				First Stage "COOL" Speed				Second Stage "COOL" Speed			
	1	2	3	4	1	2	3	4	1	2	3	4
	cfm	cfm	cfm	cfm	cfm	cfm	cfm	cfm	cfm	cfm	cfm	cfm
+	1600	1835	2030	2190	1110	1285	1380	1615	1600	1835	2030	2190
NORM	1465	1675	1855	2085	1000	1160	1250	1470	1465	1675	1855	2085
-	1320	1500	1675	1890	895	1035	1115	1320	1320	1500	1675	1890

NOTES - All air data measured external to unit with dry coil and 1 inch non-pleated air filter in place. Electric heaters have no appreciable air resistance.

First stage cooling air volume is 70% of COOL speed setting. Continuous blower speed is approximately 50% of COOL speed setting.

Allied LZSV Variable Zoning System applications - minimum blower speed is 450 cfm.

7AH1AV-060 BLOWER MOTOR WATTS

AT "+" (Plus) SETTING ("Adjust" Jumper at "+" Setting)

Jumper Speed Positions		Motor Watts @ Various External Static Pressures - in. wg.							
		0.1	0.2	0.3	0.4	0.5	0.6	0.7	0.8
"HEAT" Speed	Tap 1	330	360	403	444	488	521	563	600
	Tap 2	469	505	564	616	649	685	735	776
	Tap 3	631	671	734	782	832	894	931	974
	Tap 4	903	957	1016	1015	1013	1002	1002	998
First Stage "COOL" Speed	Tap 1	146	166	194	223	267	300	340	379
	Tap 2	195	221	252	278	319	358	383	427
	Tap 3	225	260	286	319	357	399	427	466
	Tap 4	339	382	417	447	494	532	567	611
Second Stage "COOL" Speed	Tap 1	330	360	403	444	488	521	563	600
	Tap 2	469	505	564	616	649	685	735	776
	Tap 3	631	671	734	782	832	894	931	974
	Tap 4	903	957	1016	1015	1013	1002	1002	998

AT "NORM" SETTING ("Adjust" Jumper at NORM Setting)

Jumper Speed Positions		Motor Watts @ Various External Static Pressures - in. wg.							
		0.1	0.2	0.3	0.4	0.5	0.6	0.7	0.8
"HEAT" Speed	Tap 1	251	288	320	355	391	440	463	514
	Tap 2	348	397	433	482	515	565	607	650
	Tap 3	472	524	578	614	664	704	749	810
	Tap 4	696	740	792	856	886	939	984	983
First Stage "COOL" Speed	Tap 1	110	105	164	196	233	263	297	320
	Tap 2	152	182	205	244	271	300	347	387
	Tap 3	177	205	238	271	311	341	375	424
	Tap 4	254	298	331	367	408	444	473	527
Second Stage "COOL" Speed	Tap 1	251	288	320	355	391	440	463	514
	Tap 2	348	397	433	482	515	565	607	650
	Tap 3	472	524	578	614	664	704	749	810
	Tap 4	696	740	792	856	886	939	984	983

AT "-" (Minus) SETTING ("Adjust" Jumper at "-" Setting)

Jumper Speed Positions		Motor Watts @ Various External Static Pressures - in. wg.							
		0.1	0.2	0.3	0.4	0.5	0.6	0.7	0.8
"HEAT" Speed	Tap 1	189	228	263	294	328	358	403	430
	Tap 2	268	304	343	380	427	461	483	549
	Tap 3	355	401	431	487	523	569	611	642
	Tap 4	506	549	607	646	689	720	775	834
First Stage "COOL" Speed	Tap 1	88	119	139	173	198	244	260	275
	Tap 2	117	145	169	200	225	272	309	338
	Tap 3	130	161	187	217	253	286	325	368
	Tap 4	192	237	265	295	324	364	405	440
Second Stage "COOL" Speed	Tap 1	189	228	263	294	328	358	403	430
	Tap 2	268	304	343	380	427	461	483	549
	Tap 3	355	401	431	487	523	569	611	642
	Tap 4	506	549	607	646	689	720	775	834

ELECTRIC HEAT DATA		7AH1AV-018 SINGLE PHASE					
Electric Heat Model Number		Input			Blower Motor Full Load Amps	² Minimum Circuit Ampacity	³ Maximum Overcurrent Protection
		Volt	kW	¹ Btuh			
5 kW	ECB45-5 (27A09) Terminal Block ECB45-5CB (27A13) 30A Circuit Breaker	208	3.6	12,300	3.9	27	30
		220	4.0	13,800	3.9	28	30
		230	4.4	15,000	3.9	29	30
		240	4.8	16,400	3.9	30	30
7.5 kW	ECB45-7.5 (27A10) Terminal Block ECB45-7.5CB (27A14) 45A Circuit Breaker	208	5.6	19,200	3.9	39	⁴ 40
		220	6.3	21,500	3.9	41	45
		230	6.9	23,500	3.9	42	45
		240	7.5	25,600	3.9	44	45
10 kW	ECB45-10 (27A11) Terminal Block ECB45-10CB (27A15) 60A Circuit Breaker	208	7.2	24,600	3.9	48	⁴ 50
		220	8.0	27,500	3.9	51	60
		230	8.8	30,000	3.9	53	60
		240	9.6	32,700	3.9	55	60

ELECTRIC HEAT DATA		7AH1AV-024 SINGLE PHASE					
Electric Heat Model Number		Input			Blower Motor Full Load Amps	² Minimum Circuit Ampacity	³ Maximum Overcurrent Protection
		Volt	kW	¹ Btuh			
5 kW	ECB45-5 (27A09) Terminal Block ECB45-5CB (27A13) 30A Circuit Breaker	208	3.6	12,300	3.9	27	30
		220	4.0	13,800	3.9	28	30
		230	4.4	15,000	3.9	29	30
		240	4.8	16,400	3.9	30	30
7.5 kW	ECB45-7.5 (27A10) Terminal Block ECB45-7.5CB (27A14) 45A Circuit Breaker	208	5.6	19,200	3.9	39	⁴ 40
		220	6.3	21,500	3.9	41	45
		230	6.9	23,500	3.9	42	45
		240	7.5	25,600	3.9	44	45
10 kW	ECB45-10 (27A11) Terminal Block ECB45-10CB (27A15) 60A Circuit Breaker	208	7.2	24,600	3.9	48	⁴ 50
		220	8.0	27,500	3.9	51	60
		230	8.8	30,000	3.9	53	60
		240	9.6	32,700	3.9	55	60

NOTE - Circuit 1 Minimum Circuit Ampacity includes the Blower Motor Full Load Amps.

¹ Electric heater capacity only - does not include additional blower motor heat capacity.

² Refer to National or Canadian Electrical Code manual to determine wire, fuse and disconnect size requirements. Use wires suitable for at least 167°F.

³ HACR type breaker or fuse.

⁴ Bold indicates that the circuit breaker on "CB" circuit breaker models must be replaced with size shown. See table on page 7.

ELECTRIC HEAT DATA

7AH1AV-030 | SINGLE PHASE

Electric Heat Model Number	Input			Blower Motor Full Load Amps	² Minimum Circuit Ampacity		³ Maximum Overcurrent Protection		Single Point Power Source	
	Volt	kW	¹ Btuh		Ckt 1	Ckt 2	Ckt 1	Ckt 2	² Minimum Circuit Ampacity	³ Maximum Overcurrent Protection
5 kW ECB45-5 (27A09) Terminal Block ECB45-5CB (27A13) 30A Circuit Breaker	208	3.6	12,300	3.9	27	---	30	---	---	---
	220	4.0	13,800	3.9	28	---	30	---	---	---
	230	4.4	15,000	3.9	29	---	30	---	---	---
	240	4.8	16,400	3.9	30	---	30	---	---	---
7.5 kW ECB45-7.5 (27A10) Terminal Block ECB45-7.5CB (27A14) 45A Circuit Breaker	208	5.6	19,200	3.9	39	---	40	---	---	---
	220	6.3	21,500	3.9	41	---	45	---	---	---
	230	6.9	23,500	3.9	42	---	45	---	---	---
	240	7.5	25,600	3.9	44	---	45	---	---	---
10 kW ECB45-10 (27A11) Terminal Block ECB45-10CB (27A15) 60A Circuit Breaker	208	7.2	24,600	3.9	48	---	50	---	---	---
	220	8.0	27,500	3.9	51	---	60	---	---	---
	230	8.8	30,000	3.9	53	---	60	---	---	---
	240	9.6	32,700	3.9	55	---	60	---	---	---
12.5 kW ECB45-12.5CB (27A16) (1) 50A and (1) 25A Circuit Breaker	208	9.4	32,000	3.9	42	19	45	20	61	70
	220	10.5	35,800	3.9	45	20	45	20	65	70
	230	11.5	39,200	3.9	46	21	50	25	67	70
	240	12.5	42,600	3.9	48	22	50	25	70	70
15 kW ECB45-15CB (27A17) (1) 60A and (1) 25A Circuit Breaker	208	10.8	36,900	3.9	48	22	50	25	70	70
	220	12.1	41,300	3.9	51	23	60	25	74	80
	230	13.2	45,100	3.9	53	24	60	25	77	80
	240	14.4	49,100	3.9	55	25	60	25	80	80

NOTE - Circuit 1 Minimum Circuit Ampacity includes the Blower Motor Full Load Amps.

¹ Electric heater capacity only - does not include additional blower motor heat capacity.

² Refer to National or Canadian Electrical Code manual to determine wire, fuse and disconnect size requirements. Use wires suitable for at least 167°F.

³ HACR type breaker or fuse.

⁴ Bold indicates that the circuit breaker on "CB" circuit breaker models must be replaced with size shown. See table on page 7.

ELECTRIC HEAT DATA

7AH1AV-036 | SINGLE PHASE

Electric Heat Model Number	Input			Blower Motor Full Load Amps	² Minimum Circuit Ampacity		³ Maximum Overcurrent Protection		Single Point Power Source	
	Volt	kW	¹ Btuh		Ckt 1	Ckt 2	Ckt 1	Ckt 2	² Minimum Circuit Ampacity	³ Maximum Overcurrent Protection
5 kW ECB45-5 (27A09) Terminal Block ECB45-5CB (27A13) 30A Circuit Breaker	208	3.6	12,300	3.9	27	---	30	---	---	---
	220	4.0	13,800	3.9	28	---	30	---	---	---
	230	4.4	15,000	3.9	29	---	30	---	---	---
	240	4.8	16,400	3.9	30	---	30	---	---	---
7.5 kW ECB45-7.5 (27A10) Terminal Block ECB45-7.5CB (27A14) 45A Circuit Breaker	208	5.6	19,200	3.9	39	---	⁴40	---	---	---
	220	6.3	21,500	3.9	41	---	45	---	---	---
	230	6.9	23,500	3.9	42	---	45	---	---	---
	240	7.5	25,600	3.9	44	---	45	---	---	---
10 kW ECB45-10 (27A11) Terminal Block ECB45-10CB (27A15) 60A Circuit Breaker	208	7.2	24,600	3.9	48	---	⁴50	---	---	---
	220	8.0	27,500	3.9	51	---	60	---	---	---
	230	8.8	30,000	3.9	53	---	60	---	---	---
	240	9.6	32,700	3.9	55	---	60	---	---	---
12.5 kW ECB45-12.5CB (27A16) (1) 50A and (1) 25A Circuit Breaker	208	9.4	32,000	3.9	42	19	⁴45	⁴20	61	70
	220	10.5	35,800	3.9	45	20	⁴45	⁴20	65	70
	230	11.5	39,200	3.9	46	21	50	25	67	70
	240	12.5	42,600	3.9	48	22	50	25	70	70
15 kW ECB45-15CB (27A17) (1) 60A and (1) 25A Circuit Breaker	208	10.8	36,900	3.9	48	22	⁴50	25	70	70
	220	12.1	41,300	3.9	51	23	60	25	74	80
	230	13.2	45,100	3.9	53	24	60	25	77	80
	240	14.4	49,100	3.9	55	25	60	25	80	80

NOTE - Circuit 1 Minimum Circuit Ampacity includes the Blower Motor Full Load Amps.

¹ Electric heater capacity only - does not include additional blower motor heat capacity.

² Refer to National or Canadian Electrical Code manual to determine wire, fuse and disconnect size requirements. Use wires suitable for at least 167°F.

³ HACR type breaker or fuse.

⁴ Bold indicates that the circuit breaker on "CB" circuit breaker models must be replaced with size shown. See table on page 7.

ELECTRIC HEAT DATA

7AH1AV-042 | SINGLE PHASE

Electric Heat Model Number	Input			Blower Motor Full Load Amps	² Minimum Circuit Ampacity		³ Maximum Overcurrent Protection		Single Point Power Source	
	Volt	kW	¹ Btuh		Ckt 1	Ckt 2	Ckt 1	Ckt 2	² Minimum Circuit Ampacity	³ Maximum Overcurrent Protection
5 kW ECB45-5 (27A09) Terminal Block ECB45-5CB (27A13) 30A Circuit Breaker	208	3.6	12,300	6.9	30	---	30	---	---	---
	220	4.0	13,800	6.9	32	---	35	---	---	---
	230	4.4	15,000	6.9	33	---	35	---	---	---
	240	4.8	16,400	6.9	34	---	35	---	---	---
7.5 kW ECB45-7.5 (27A10) Terminal Block ECB45-7.5CB (27A14) 45A Circuit Breaker	208	5.6	19,200	6.9	42	---	45	---	---	---
	220	6.3	21,500	6.9	44	---	45	---	---	---
	230	6.9	23,500	6.9	46	---	50	---	---	---
	240	7.5	25,600	6.9	48	---	50	---	---	---
10 kW ECB45-10 (27A11) Terminal Block ECB45-10CB (27A15) 60A Circuit Breaker	208	7.2	24,600	6.9	52	---	60	---	---	---
	220	8.0	27,500	6.9	54	---	60	---	---	---
	230	8.8	30,000	6.9	57	---	60	---	---	---
	240	9.6	32,700	6.9	59	---	60	---	---	---
12.5 kW ECB45-12.5CB (27A16) (1) 50A and (1) 25A Circuit Breaker	208	9.4	32,000	6.9	46	19	50	20	65	70
	220	10.5	35,800	6.9	48	20	50	20	68	70
	230	11.5	39,200	6.9	50	21	50	25	71	80
	240	12.5	42,600	6.9	52	22	60	25	74	80
15 kW ECB45-15CB (27A17) (1) 60A and (1) 25A Circuit Breaker	208	10.8	36,900	6.9	52	22	60	25	74	80
	220	12.1	41,300	6.9	54	23	60	25	77	80
	230	13.2	45,100	6.9	57	24	60	25	80	80
	240	14.4	49,100	6.9	59	25	60	25	84	90

NOTE - Circuit 1 Minimum Circuit Ampacity includes the Blower Motor Full Load Amps.

¹ Electric heater capacity only - does not include additional blower motor heat capacity.

² Refer to National or Canadian Electrical Code manual to determine wire, fuse and disconnect size requirements. Use wires suitable for at least 167°F.

³ HACR type breaker or fuse.

⁴ **Bold indicates that the circuit breaker on "CB" circuit breaker models must be replaced with size shown. See table on page 7.**

ELECTRIC HEAT DATA

7AH1AV-048 | 7AH1AV-060 | SINGLE PHASE

Electric Heat Model Number	Input			Blower Motor Full Load Amps	² Minimum Circuit Ampacity		³ Maximum Overcurrent Protection		Single Point Power Source	
	Volt	kW	¹ Btuh		Ckt 1	Ckt 2	Ckt 1	Ckt 2	² Minimum Circuit Ampacity	³ Maximum Overcurrent Protection
5 kW ECB45-5 (27A09) Terminal Block ECB45-5CB (27A13) 30A Circuit Breaker	208	3.6	12,300	6.9	30	---	30	---	---	---
	220	4.0	13,800	6.9	32	---	⁴ 35	---	---	---
	230	4.4	15,000	6.9	33	---	⁴ 35	---	---	---
	240	4.8	16,400	6.9	34	---	⁴ 35	---	---	---
7.5 kW ECB45-7.5 (27A10) Terminal Block ECB45-7.5CB (27A14) 45A Circuit Breaker	208	5.6	19,200	6.9	42	---	45	---	---	---
	220	6.3	21,500	6.9	44	---	45	---	---	---
	230	6.9	23,500	6.9	46	---	⁴ 50	---	---	---
	240	7.5	25,600	6.9	48	---	⁴ 50	---	---	---
10 kW ECB45-10 (27A11) Terminal Block ECB45-10CB (27A15) 60A Circuit Breaker	208	7.2	24,600	6.9	52	---	60	---	---	---
	220	8.0	27,500	6.9	54	---	60	---	---	---
	230	8.8	30,000	6.9	57	---	60	---	---	---
	240	9.6	32,700	6.9	59	---	60	---	---	---
12.5 kW ECB45-12.5CB (27A16) (1) 50A and (1) 25A Circuit Breaker	208	9.4	32,000	6.9	46	19	50	⁴ 20	65	70
	220	10.5	35,800	6.9	48	20	50	⁴ 20	68	70
	230	11.5	39,200	6.9	50	21	50	25	71	80
	240	12.5	42,600	6.9	52	22	⁴ 60	25	74	80
15 kW ECB45-15CB (27A17) (1) 60A and (1) 25A Circuit Breaker	208	10.8	36,900	6.9	52	22	60	25	74	80
	220	12.1	41,300	6.9	54	23	60	25	77	80
	230	13.2	45,100	6.9	57	24	60	25	80	80
	240	14.4	49,100	6.9	59	25	60	25	84	90
20 kW ECB45-20CB (27A18) (1) 60A and (1) 50A Circuit Breaker	208	14.4	49,200	6.9	52	43	60	⁴ 45	95	100
	220	16.1	55,000	6.9	54	46	60	50	100	100
	230	17.6	60,100	6.9	57	48	60	50	104	110
	240	19.2	65,500	6.9	59	50	60	50	109	110

NOTE - Circuit 1 Minimum Circuit Ampacity includes the Blower Motor Full Load Amps.

¹ Electric heater capacity only - does not include additional blower motor heat capacity.

² Refer to National or Canadian Electrical Code manual to determine wire, fuse and disconnect size requirements. Use wires suitable for at least 167°F.

³ HACR type breaker or fuse.

⁴ Bold indicates that the circuit breaker on "CB" circuit breaker models must be replaced with size shown. See table on page 7.

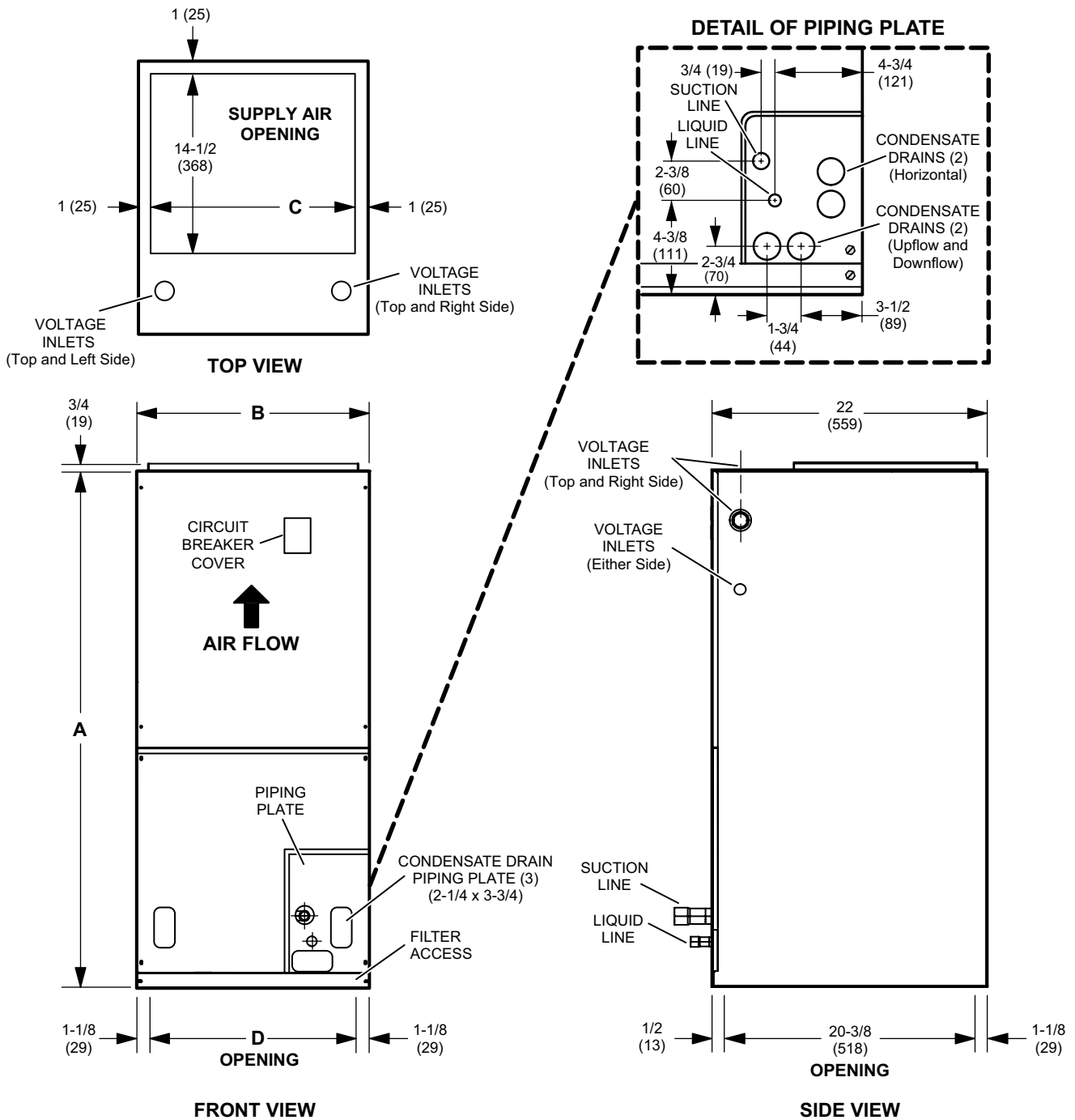

Dimensions	018		024		030		036, 042		048		060	
	in.	mm	in.	mm	in.	mm	in.	mm	in.	mm	in.	mm
A	43-1/2	1105	45-1/2	1156	47	1194	53-5/8	1362	55	1397	59-3/4	1518
B	18-1/2	470	18-1/2	470	18-1/2	470	21-1/2	546	21-1/2	546	21-1/2	546
C	16-1/2	419	16-1/2	419	16-1/2	419	19-1/2	495	19-1/2	495	19-1/2	495
D	16-1/4	413	16-1/4	413	16-1/4	413	19-1/4	489	19-1/4	489	19-1/4	489

DIMENSIONS

UNIT - HORIZONTAL POSITION

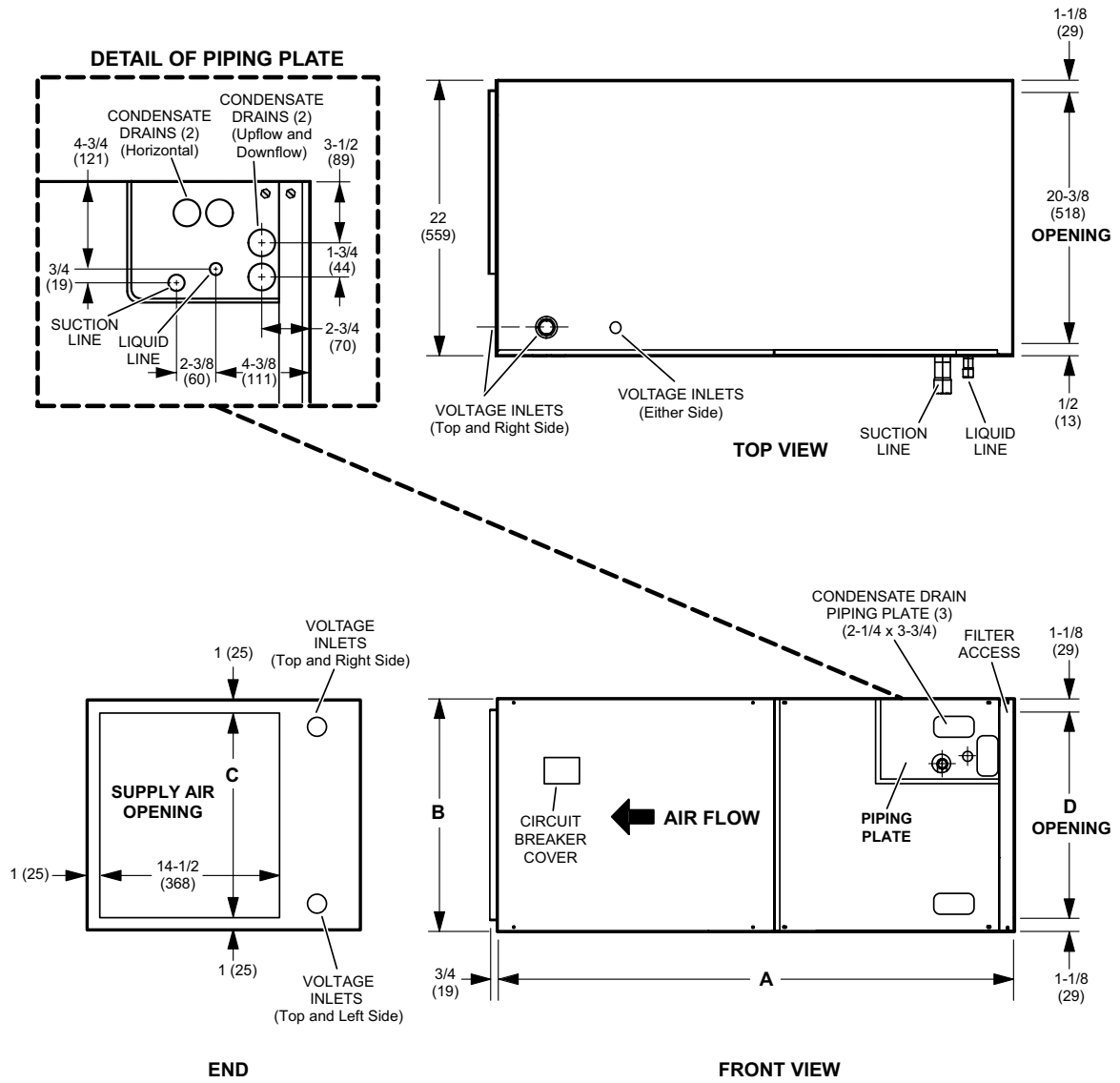

Dimensions	018		024		030		036, 042		048		060	
	in.	mm	in.	mm	in.	mm	in.	mm	in.	mm	in.	mm
A	43-1/2	1105	45-1/2	1156	47	1194	53-5/8	1362	55	1397	59-3/4	1518
B	18-1/2	470	18-1/2	470	18-1/2	470	21-1/2	546	21-1/2	546	21-1/2	546
C	16-1/2	419	16-1/2	419	16-1/2	419	19-1/2	495	19-1/2	495	19-1/2	495
D	16-1/4	413	16-1/4	413	16-1/4	413	19-1/4	489	19-1/4	489	19-1/4	489

HORIZONTAL SUPPORT FRAME KIT

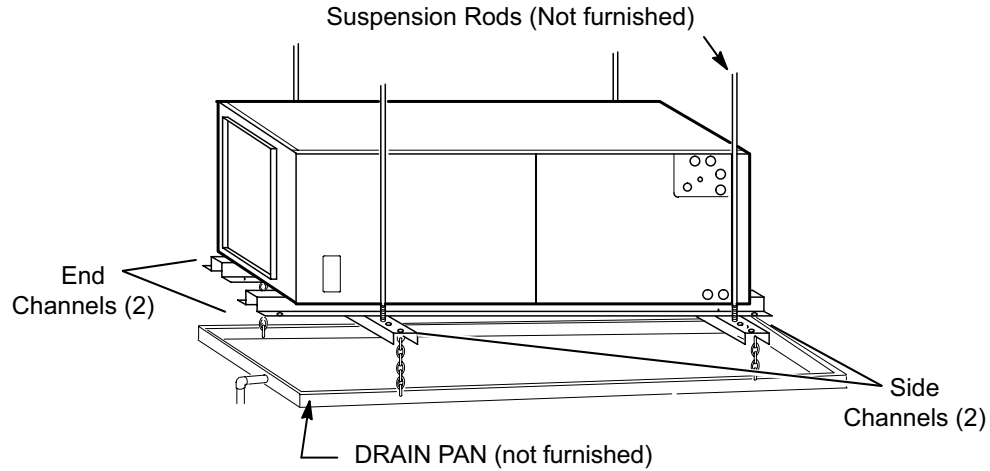

Includes (2) 1 x 1-1/2 x 32-5/8 in. side channels and (2) 1 x 3 x 53-7/8 in. end channels.

**SIDE RETURN UNIT STAND
(Upflow Only)**

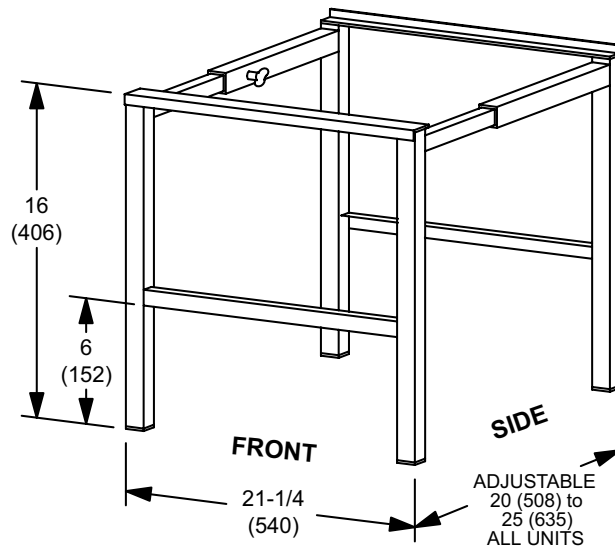



Contact us at 1-800-448-5872

NOTE - Due to our ongoing commitment to quality, Specifications, Ratings and Dimensions subject to change without notice and without incurring liability. Improper installation, adjustment, alteration, service or maintenance can cause property damage or personal injury. Installation and service must be performed by a qualified installer and servicing agency.

©2024 Allied Air Enterprises.