

Liberty Pumps®

LowPro41LP

Fully
Assembled
System!



Patent: See
www.libertypumps.com/patents



(toilet not included)

Low Profile Sewage System

For addition of a toilet without breaking concrete floors. Mounts freestanding or can be built-in using 2" x 6" joists for a more professional looking installation. Additional fixtures such as a shower or sink can be easily added using the optional inlet seal (provided).

Features:

- 2" solids-handling sewage pump
 - 4/10 hp 115V
- Durable poly tank with separate access opening to switch
- Fully assembled unit, including pump, piping and switch. Saves valuable installation time.

innovate. evolve.

LowPro41LP

SAMPLE INSTALLATIONS

The LowPro41LP can be installed freestanding or built-in, concealing the pump compartment and piping. The platform section of the tank is sized to fit flush with an elevated floor framed with 2" x 6" material.

Note: Access to pump compartment is required on built-in installations.

For addition of a lavatory or shower, a rubber pipe seal is included. Seal accepts 2" schedule 40 PVC piping. Showers must be elevated to allow gravity flow to unit.

Some possible arrangements using the LowPro41LP:

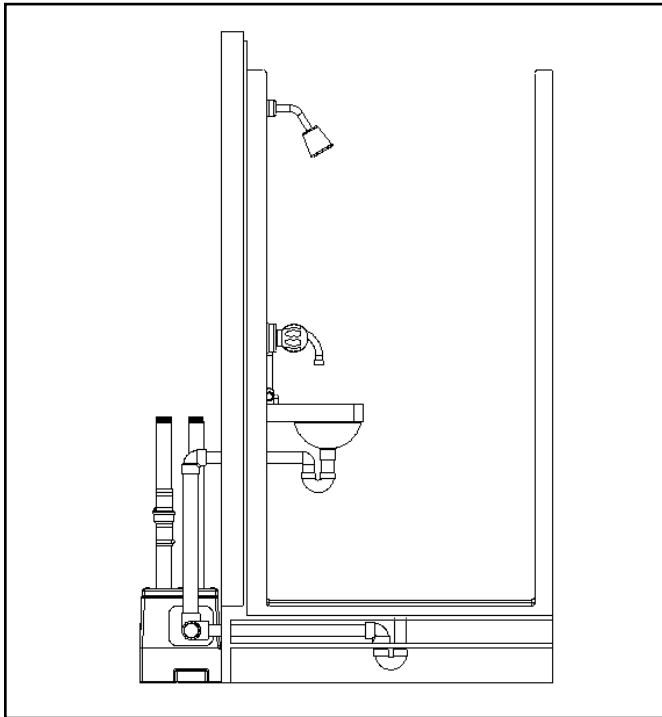

Side view with shower and lavatory.

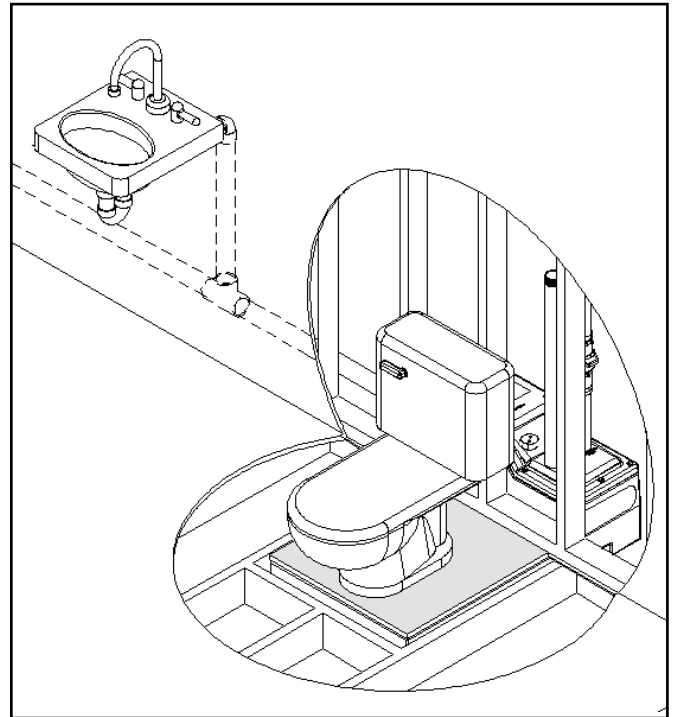

View with wall and floor framing.

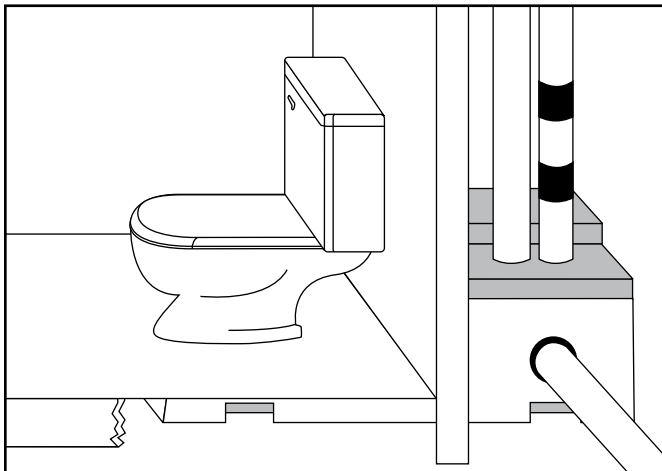

Built-in (hidden)

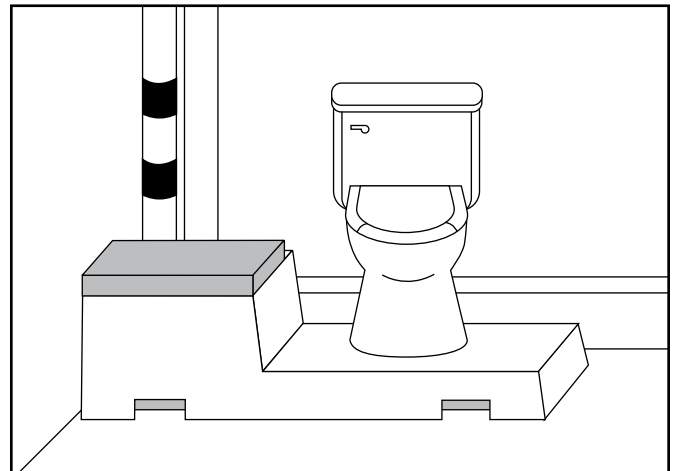

Exposed corner location

top view

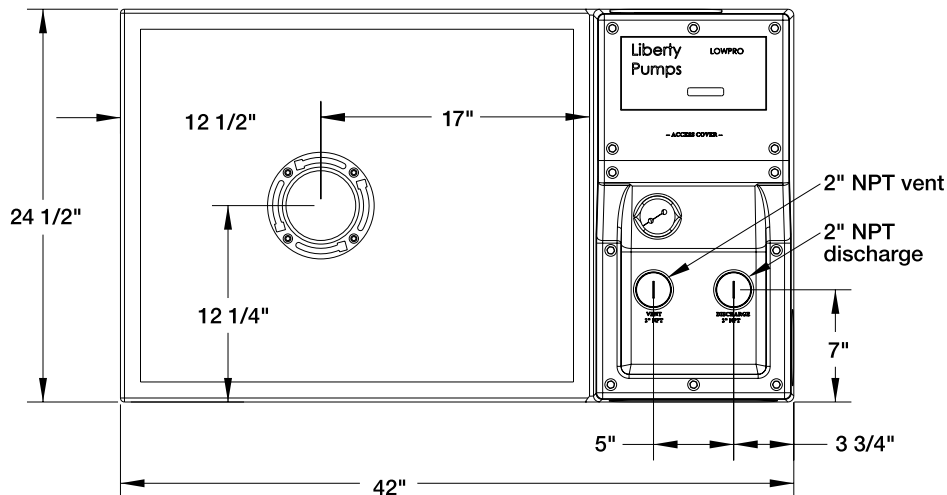

side view

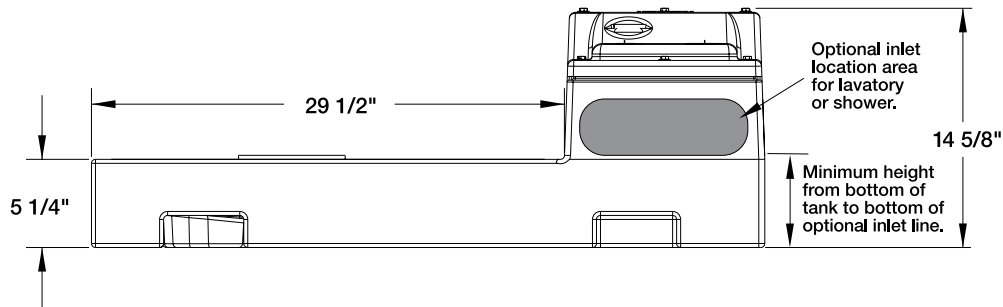

FULLY ASSEMBLED SYSTEM FEATURES:

- Durable one-piece poly tank with split cover design – allows access to switch area without disturbing discharge and vent piping.
- 4/10 hp cast iron sewage pump, 2" solids-handling.
- Pre-mounted float switch.
- Schedule 80 PVC discharge pipe (internal).
- 2" check valve.
- Closet flange with extra spacers for optional floor heights. (1/4" and 1/2" provided)
- Pipe grommet seal for additional 2" inlet pipe from a shower or sink.
- Engineered water jet provides a powerful spray within the tank to help break down solids and reduce potential jamming.
- Flow-adjusted pump maximizes pump cycle time and increases pump life.

SPECIFICATIONS:

4/10 hp 115V 12 amps 60Hz 1550 RPM

Maximum fluid temperature: 140°F.

Assembled weight: 91 lbs.

PERFORMANCE CURVE

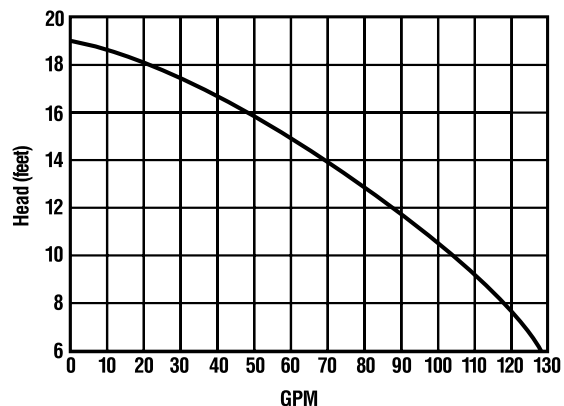

SA [®]
c us Constructed with Certified Pump

www.
libertypumps
.com



Liberty Pumps • 7000 Apple Tree Avenue • Bergen, New York 14416
Phone 800-543-2550 Fax (585) 494-1839

Specifications are subject to change without notice. Copyright © Liberty Pumps, Inc. 2018 All rights reserved. LLIT1800 R01/18