

MSZ-GS12NA

12,000 BTU/H WALL-MOUNTED INDOOR UNIT



Job Name:

System Reference:

Date:



GENERAL FEATURES

- Slim wall-mounted indoor units provide zone comfort control
- Dual Barrier Coating applied to the heat exchanger, vanes and fan to prevent hydrophilic and hydrophobic dirt build-up
- Optional Microparticle Filter designed to capture PM2.5
- The outdoor unit powers the indoor unit, and should a power outage occur, the system is automatically restarted when power returns
- Quiet operation
- Smart Set: recalls a preferred preset temperature setting at the touch of a button
- Built-in backup/auxiliary heater control available
- Multiple fan speed options: Quiet, Low, Medium, High, Super-high, Auto
- Multiple control options available:
 - Back-lit screen handheld remote controller (provided with the unit)
 - kumo cloud® smart device app for remote access
 - Third-party interface options
 - Wired or wireless controllers

| Specifications | | System | |
|---------------------------------|-------------------------------------|---------------------|--|
| Unit Type | | MSZ-GS12NA | |
| Cooling Capacity ^{1,3} | BTU/H | 12,000 | |
| Heating Capacity ^{2,3} | BTU/H | 14,400 | |
| Electrical | Voltage, Phase, Frequency | 208/230, 1, 60 | |
| | Guaranteed Voltage Range | 187 - 253 | |
| | Voltage: Indoor - Outdoor, S1-S2 | 208/230 | |
| | Voltage: Indoor - Outdoor, S2-S3 | 24 | |
| | Short-circuit Current Rating [SCCR] | 5 | |
| Indoor Unit | MCA | 1.0 | |
| | Fan Motor Full Load Amperage | 0.5 | |
| | Fan Motor Output | 30 | |
| | Airflow Rate at Cooling, Dry | CFM | 134-160-222-307-381 |
| | Airflow Rate at Cooling, Wet | CFM | 121-144-200-276-343 |
| | Airflow Rate at Heating, Dry | CFM | 134-160-222-307-390 |
| | Sound Pressure Level [Cooling] | dB[A] | 19-22-30-37-45 |
| | Sound Pressure Level [Heating] | dB[A] | 19-22-30-37-43 |
| | Drain Pipe Size | In. [mm] | 5/8 [15.88] |
| | Coating on Heat Exchanger | | Dual Barrier Coating |
| | External Finish Color | | Munsell 1.0Y 9.2/0.2 |
| | Unit Dimensions | W x D x H: In. [mm] | 31-7/16 x 9-1/8 x 11-5/8 [798 x 232 x 295] |
| | Package Dimensions | W x D x H: In. [mm] | 33-1/2 x 12 x 14 [850 x 300 x 350] |
| | Unit Weight | Lbs. [kg] | 23 [10.4] |
| | Package Weight | Lbs. [kg] | 26 [11.5] |
| Refrigerant | Type | R410A | |
| Piping | Gas Pipe Size O.D. [Flared] | In.[mm] | 3/8 [9.52] |
| | Liquid Pipe Size O.D. [Flared] | In.[mm] | 1/4 [6.35] |

NOTES:
 Conditions ¹Cooling (Indoor // Outdoor) °F 80 DB, 67 WB // 95 DB, 75 WB
²Heating at 47°F (Indoor // Outdoor) °F 70 DB, 60 WB // 47 DB, 43 WB

³Capacity varies based on the number of indoor units operating and the model of the Multi-zone Outdoor Unit. For reference to connected capacity charts, please refer Multi-zone Outdoor Unit Operational Performance.

INDOOR UNIT ACCESSORIES: MSZ-GS12NA

| | | |
|-----------------------------|---|-------------------|
| Control Interface | BACnet® and Modbus® Interface | PAC-UKPRC001-CN-1 |
| | CN24 Relay Kit | CN24RELAY-KIT-CM3 |
| | IT Extender | PAC-WHS01IE-E |
| | kumo station® for kumo cloud® | PAC-WHS01HC-E |
| | System Control Interface | MAC-334IF-E |
| | Thermostat Interface | PAC-US444CN-1 |
| | Thermostat Interface | PAC-US445CN-1 |
| | USNAP Adapter | PAC-WHS01UP-E |
| | Wireless Interface for kumo cloud® | PAC-USWHS002-WF-2 |
| Remote Sensor | Wired Remote Sensor | M21EAA307 |
| | Wireless temperature and humidity sensor for kumo cloud® | PAC-USWHS003-TH-1 |
| Wired Remote Controller | Deluxe Wired MA Remote Controller† | PAR-40MAAU |
| | Simple Ductless Wired Remote Controller | PAC-SDW01RC-1 |
| | Simple MA Remote Controller† | PAC-YT53CRAU-J |
| | Touch MA Controller† | PAR-CT01MAU-SB |
| Wireless Remote Controller | kumo touch™ RedLINK™ Wireless Controller | MHK2 |
| | Lockdown bracket for remote controller | RCMKP1CB |
| Condensate | Blue Diamond (Advanced) Mini Condensate Pump w/ Reservoir & Sensor (208/230V) [recommended] | X87-721 |
| | Blue Diamond (MegaBlue Advanced) Condensate Pump w/ Reservoir & Sensor | X87-835 |
| | Blue Diamond Alarm Extension Cable — 6.5 Ft. | C13-192 |
| | Blue Diamond MultiTank — collection tank for use with multiple pumps | C21-014 |
| | Blue Diamond Sensor Extension Cable — 15 Ft. | C13-103 |
| | Drain Pan Level Sensor/Control | SS610E |
| | Fascia Kit for MicroBlue Pump, mounts the MicroBlue and sensor directly beneath indoor unit | T18-016 |
| | Refco Condensate Pump (100-240 VAC) | GOBI-II |
| | Refco Condensate Pump (100-240 VAC) up to 120,000 BTU/H | COMBI |
| Sauerermann Condensate Pump | SI30-230 | |
| Disconnect Switch | (30A/600V/UL) [fits 2" X 4" utility box] - Black | TAZ-MS303 |
| | (30A/600V/UL) [fits 2" X 4" utility box] - White | TAZ-MS303W |
| Filter | Anti-allergy Enzyme Filter | MAC-408FT-E |
| | Microparticle (PM2.5) Filter | MAC-EMF515FT-E |

NOTES:

†Requires MAC-334IF-E

- M-Series EZ FIT® Recessed Ceiling Cassette, Floor-mount and Wall-mount
Allows indoor units to connect to an MA Controller:
 - Deluxe MA Remote Controller
 - Simple MA Controller
 - Touch MA Controller

INDOOR UNIT DIMENSIONS: MSZ-GS12NA

Unit: inch

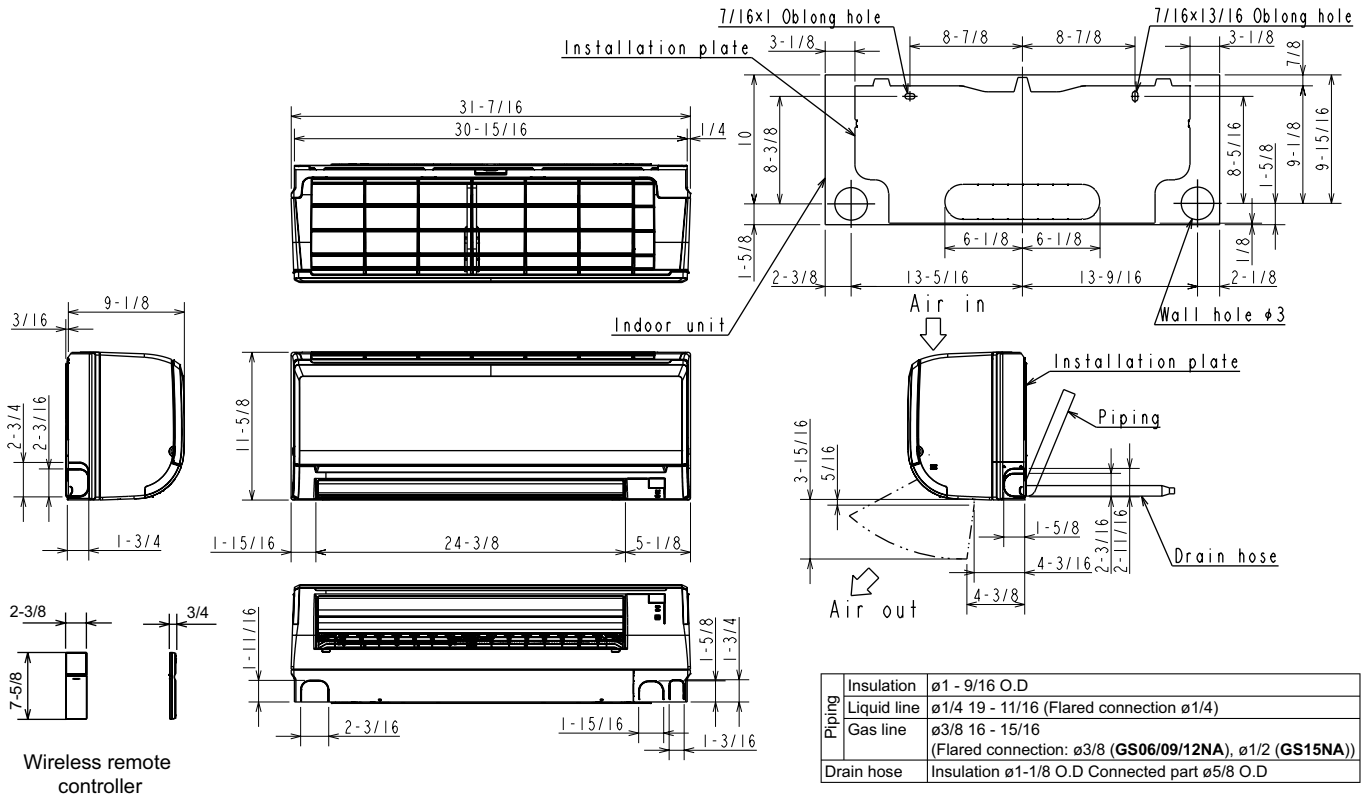

FORM# MSZ-GS12NA-U1 - 202304

1340 Satellite Boulevard Suwanee, GA 30024
Toll Free: 800-433-4822 www.mehvac.com

