

Heavy-duty systems for roof-top (RTU) installations. High output UVC lamps produce the strongest germicidal output in the industry, while the PCO process breaks down odors. The NEMA 4-Rated, water-proof and weather-proof enclosure protects the unit and the RTU.

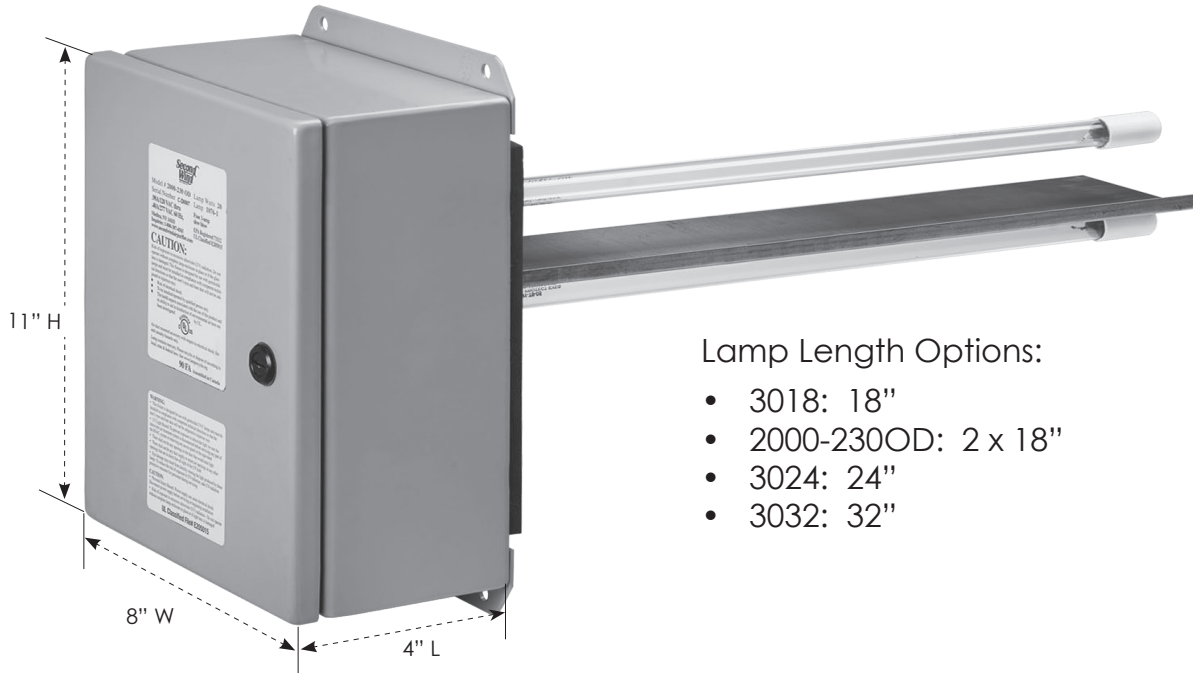

### Lamp Length Options:

- 3018: 18"
- 2000-230OD: 2 x 18"
- 3024: 24"
- 3032: 32"

### Reduce Maintenance Costs

Clean HVAC coils require less maintenance and reduce the need for chemical cleaning treatments. Even a microscopic layer of mold can reduce efficiency by 40%!



Moldy Coils

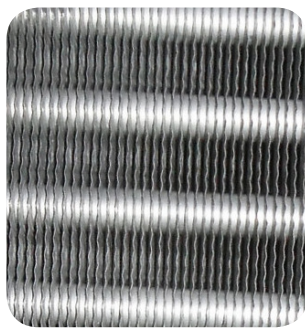

Coils With UV Light

### Eliminate Pollutants

Second Wind™ UV air purifiers prevent mold growth on furnace coils, degrade viruses, germs, bacteria, and other airborne pathogens that would otherwise be introduced into the air.





# Commercial / Industrial NEMA Series UV Air Purifiers

## Specifications

Installed on roof-top and outdoor applications, the NEMA 4-Series provide the appropriate UV dose to disinfect mold, bacteria, and infectious disease in the airstream and on coil surfaces.

### NEMA Series Single Unit Sizing

Tonnage	< 4.5t	5.0t	7.5t	10.0t	12.5t	15.0t
cfm	< 1800	2000	3000	4000	5000	6000
3018	■	■				
3024	■	■	■	■		
3032	■	■	■	■	■	■
2000-230OD	■	■	■	■	■	■

### NEMA Series Dual Unit Sizing

Tonnage	20.0t	25.0t	30.0t	40.0t	50.0t
cfm	8000	10000	12000	16000	20000
(2x) 3024	■				
(2x) 3032	■	■	■	■	
(2x) 2000-230OD	■	■	■		

### Product Specs

Product Specs	2000-230 OD GFI #4906	3018 GFI #4955	3024 GFI #4957	3032 GFI #4958
POWER REQUIREMENT	120-277V			
AMPERAGE DRAW	0.9A AT 120V / 0.4A AT 277V			
LINE CORD	N/A			
STARTING	HARDWIRE			
LAMP SIZE	18"	18"	24"	32"
NUMBER OF LAMPS	2	1	1	1
DEVICE UV INTENSITY (mW/cm <sup>2</sup> ) 12" FROM SOURCE	3264	1632	2370	3108
AIRBORNE AND SURFACE MOLD DISINFECTION	•	•	•	•
ATTACKS BACTERIA AND MICRO-ORGANISMS	•	•	•	•
ODOR CONTROL	•			
PHOTO-CATALYTIC OXIDATION (PCO) MODULE	•			
REPLACEMENT LAMP	1076-1R SP GFI #4950	1076-1R SP GFI #4950	1097B-R GFI #4931	1081B-R GFI #4943
REPLACEMENT BALLAST	1060E-R GFI #4964			

### Product Features:

- Waterproof / Weatherproof; NEMA 4 Rated Enclosure
- Indoor or Outdoor Installation
- 360° Coverage
- Eradicates Mold, Bacteria, Viruses
- Disinfects Coil & Drain Pan
- Easy to Install / Easy to Service
- 1-Year Lamp Warranty
- 3-Year Ballast Warranty