



## Performance Engineered & Tested



SPEARS® Schedule 40 PVC fitting designs combine years of proven experience with computer generated stress analysis to yield the optimum physical structure and performance for each fitting. Material reinforcement is uniformly placed in stress concentration areas for substantially improved pressure handling capability. Resulting products are subjected to numerous verification tests to assure the very best PVC fittings available.

### Full 1/4" Through 12" Availability

Spears® comprehensive line of PVC fittings offers a variety of injection molded configurations in Schedule 40 sizes 1/4" through 12" conforming to ASTM D 2466.

### Exceptional Chemical & Corrosion Resistance

Unlike metal, PVC fittings never rust, scale, or pit, and will provide many years of maintenance-free service and extended system life.

### High Temperature Ratings

PVC thermoplastic can handle fluids at service temperatures up to 140°F (60°C), allowing a wide range of process applications, including corrosive fluids.

### Lower Installation Costs

Substantially lower material costs than steel alloys or lined steel, combined with lighter weight and ease of installation, can reduce installation costs by as much as 60% over conventional metal systems.

### Higher Flow Capacity

Smooth interior walls result in lower pressure loss and higher volume than conventional metal fittings.

### Additional Fabricated Configurations through 36"

Extra large, hard-to-find, and custom configurations are fabricated from NSF® Certified pipe. Fittings are engineered and tested to provide full pressure handling capabilities according to Spears® specifications.

### PVC Valves

SPEARS® PVC Valve products are available for total system compatibility and uniformity.

### Advanced Design Specialty Fittings

Spears® wide range of innovative, improved products include numerous metal-to-plastic transition fittings and unions with Spears® patented special reinforced (SR) plastic threads.

### 1/2" Through 16" Industrial Pipe Availability

Spears® premium quality Industrial CPVC pipe is offered in Schedule 40 White sizes 1/2" through 16".

### Sample Engineering Specifications

All PVC Schedule 40 fittings shall be produced by Spears® Manufacturing Company from PVC Type I cell classification 12454, conforming to ASTM D 1784. All injection molded PVC Schedule 40 fittings shall be Certified for potable water service by NSF International and manufactured in strict compliance to ASTM D 2466. All fabricated fittings shall be produced in accordance with Spears® General Specifications for Fabricated Fittings.



The information contained in this publication is based on current information and Product design at the time of publication and is subject to change without notification. Our ongoing commitment to product improvement may result in some variation. No representations, guarantees or warranties of any kind are made as to its accuracy, suitability for particular applications or results to be obtained therefrom. For verification of technical data or additional information not contained herein, please contact Spears® Technical Services Department [West Coast: (818) 364-1611 — East Coast: (678) 985-1263].

## General Information

### Recommendations For Installers And Users

Plastic piping systems should be **ENGINEERED, INSTALLED** and **OPERATED** in accordance with **ESTABLISHED DESIGN AND ENGINEERING STANDARDS AND PROCEDURES** for plastic piping systems. Suitability for the intended service application should be determined by the installer and/or user prior to installation of a plastic piping system. **PRIOR TO ASSEMBLY, all piping system components should be inspected for damage or irregularities. Mating components should be checked to assure that tolerances and engagements are compatible. Do not use any components that appear irregular or do not fit properly. Contact the appropriate manufacturer of the component product in question to determine usability. Consult all applicable codes and regulations for compliance prior to installation.**

**Solvent Weld Connections** — Use quality solvent cements and primers formulated for the intended service application, pipe size and type of joint. While the pipe and fitting materials may be compatible with the intended medium, the solvent cement may not be. Consult the manufacturers for suitability of use. Read and follow the cement and primer manufacturers' applications and cure time instructions thoroughly. Be sure to use the correct size applicator.

**Threaded Connections** — Use a quality grade thread sealant. **WARNING: SOME PIPE JOINT COMPOUNDS OR PTFE PASTES MAY CONTAIN SUBSTANCES THAT COULD CAUSE STRESS CRACKING TO PLASTIC.** Spears® Manufacturing Company recommends the use of Spears® **BLUE 75™** Thread Sealant which has been tested for compatibility with Spears® products. Please follow the sealant manufacturers' application / installation instructions. Choice of an appropriate thread sealant other than those listed above is at the discretion of the installer. 1 to 2 turns beyond **FINGER TIGHT** is generally all that is required to make a sound plastic threaded connection. Unnecessary **OVERTIGHTENING** will cause **DAMAGE TO BOTH PIPE AND FITTING.**

"Lead Free" low lead certification – unless otherwise specified, all Spears® Schedule 40 fittings specified here-in are certified by NSF International to ANSI/NSF® Standard 61, Annex G and is in compliance with California's Health & Safety Code Section 116825 (commonly known as AB1953) and Vermont Act 193. Weighted average lead content  $\leq 0.25\%$ .



# PVC WHITE SCHEDULE 40 FITTINGS UNIONS & SADDLES

## ASTM STANDARD DIMENSIONS

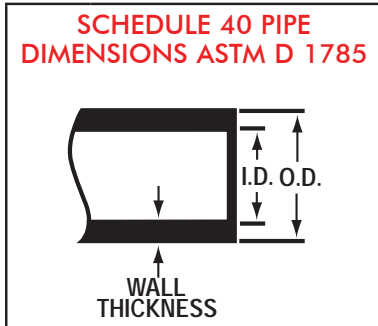

Nominal Pipe Size In.	Mean Outside Diameter In.	O. D. Tolerance In.	Minimum Wall Thickness In.
1/8	.405	± .004	.068
1/4	.540	± .004	.088
3/8	.675	± .004	.091
1/2	.840	± .004	.109
3/4	1.050	± .004	.113
1	1.315	± .005	.133
1-1/4	1.660	± .005	.140
1-1/2	1.900	± .006	.145
2	2.375	± .006	.154
2-1/2	2.875	± .007	.203
3	3.500	± .008	.216
4	4.500	± .009	.237
5	5.563	± .010	.258
6	6.625	± .011	.280
8	8.625	± .015	.322
10	10.750	± .015	.365
12	12.750	± .015	.408

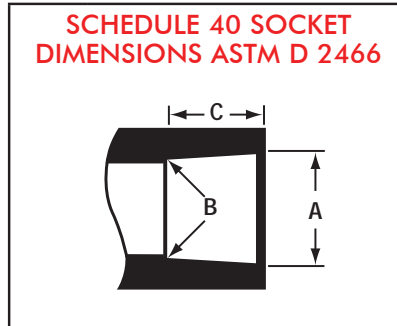

Nominal Size In.	Diameter			Socket Length Minimum C
	Entrance A	Bottom B	Tolerance A	
1/8	.417	.401	± .004	.500
1/4	.552	.536	± .004	.500
3/8	.687	.671	± .004	.594
1/2	.848	.836	± .004	.688
3/4	1.058	1.046	± .004	.719
1	1.325	1.310	± .005	.875
1-1/4	1.670	1.655	± .005	.938
1-1/2	1.912	1.894	± .006	1.094
2	2.387	2.369	± .006	1.156
2-1/2	2.889	2.868	± .007	1.750
3	3.516	3.492	± .008	1.875
4	4.518	4.491	± .009	2.000
5	5.583	5.553	± .010	3.000
6	6.647	6.614	± .011	3.000
8	8.655	8.610	± .015	4.000
10	10.780	10.735	± .015	5.000
12	12.780	12.735	± .015	6.000



Nominal Size In.	Threads Per Inch.	Effective Thread Length L	Pitch Of Thread P
1/8	27	.2639	.03704
1/4	18	.4018	.05556
3/8	18	.4078	.05556
1/2	14	.5337	.07143
3/4	14	.5457	.07143
1	11-1/2	.6828	.08696
1-1/4	11-1/2	.7068	.08696
1-1/2	11-1/2	.7235	.08696
2	11-1/2	.7565	.08696
2-1/2	8	1.1375	.12500
3	8	1.2000	.12500
4	8	1.3000	.12500
5	8	1.4063	.12500
6	8	1.5125	.12500
8	8	1.7125	.12500

Molded Schedule 40 products are manufactured to ASTM D 2466 for use with pipe manufactured to ASTM D 1785. Certain products carry reduced pressure handling capability and have maximum internal pressure ratings at 73°F noted.

Fabricated Schedule 40 pressure fittings (part numbers ending with "F") are manufactured to Spears® specifications for use with pipe manufactured to ASTM D 1785. See publication FAB-7, General Specifications for Standard Fabricated Fittings for additional information.

All specified Schedule 40 products are manufactured from materials certified by NSF® for use in potable water service.

# PVC WHITE SCHEDULE 40 FITTINGS UNIONS & SADDLES



## Injection Molded Dimension References:

- G** = (LAYING LENGTH) intersection of center lines to bottom of socket/thread; 90° elbows, tees, crosses; ± 1/32 inch.
- H** = Intersection of center lines to face of fitting; 90° elbows, tees, crosses; ± 1/32 inch.
- J** = Intersection of center lines to bottom of socket/thread; 45° elbows; ± 1/32 inch

- L** = Overall length of fittings; ± 1/16 inch.
- M** = Outside diameter of socket/thread hub; ± 1/16 inch.
- N** = Socket bottom to socket bottom; couplings; ± 1/16 inch.
- W** = Height of cap; ± 1/16 inch.

## Fabricated Dimension References:

- G** = (LAYING LENGTH) intersection of center lines to bottom of socket/thread; 90° elbows, tees, crosses; ± 1/4 inch; 14" & larger ± 1/2 inch.
- H** = Intersection of center lines to face of fitting; 90° elbows, tees, crosses; ± 1/4 inch.; wyes ± 1/2 inch; 14" & larger ± 1/2 inch.
- J** = Intersection of center lines to bottom of socket/thread; 45° elbows; ± 1/4 inch; 14" & larger ± 1/2 inch.

- L** = Overall length of fittings; ± 1/2 inch.; wyes ± 1 inch; 14" & larger ± 1 inch.
- M** = Outside diameter of socket/thread hub; ± 1/4 inch.
- N** = Socket bottom to socket bottom; couplings; ± 1/2 inch.
- W** = Height of cap; ± 1/4 inch.

## Typical Fabricated Dimension References

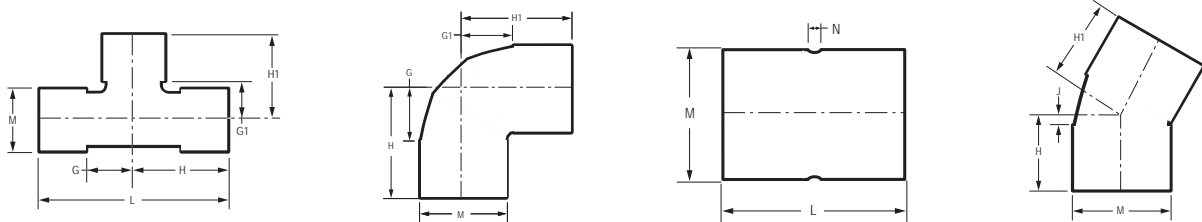

## TEE

Socket x Socket x Socket

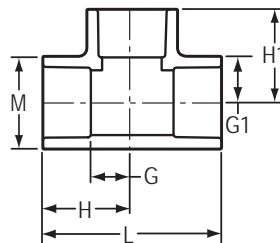

Part Number	Size	G	G1	H	H1	L	M	Approx. Wt. (Lbs.)
401-003	3/8	3/8	3/8	1-1/8	1-1/8	2-1/4	31/32	.04
401-005	1/2	1/2	1/2	1-1/4	1-1/4	2-1/2	1-3/32	.06
401-007	3/4	9/16	9/16	1-9/16	1-9/16	3-1/8	1-5/16	.10
401-010	1	11/16	11/16	1-3/4	1-3/4	3-1/2	1-5/8	.16
401-012	1-1/4	7/8	7/8	2-1/8	2-1/8	4-1/4	2	.25
401-015	1-1/2	1-3/32	1-3/32	2-11/32	2-11/32	4-11/16	2-1/4	.36
401-020	2	1-3/8	1-3/8	2-3/4	2-3/4	5-1/2	2-3/4	.51
401-025	2-1/2	1-21/32	1-21/32	3-13/32	3-13/32	6-13/16	3-11/32	1.03

# PVC WHITE SCHEDULE 40 FITTINGS UNIONS & SADDLES



## 45° ELBOW (continued)

Socket x Socket

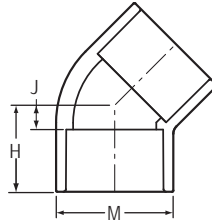

Part Number	Size	H	J	M	Approx. Wt. (Lbs.)
417-120	12	9-19/32	3-3/32	14-5/16	34.15
417-120F	12	9-19/32	3-11/32	13-9/16	17.39
417-140F	14	10-7/8	3-7/8	14-7/8	24.61
417-160F	16	12-1/2	4-1/2	17	34.85
417-180F	18	14-7/8	5-7/8	19-1/8	52.10
417-200F	20	16-1/2	6-1/2	21-3/16	68.92
417-240F	24	19-7/8	7-7/8	25-1/2	112.34

## 45° STREET ELBOW

Spigot x Socket

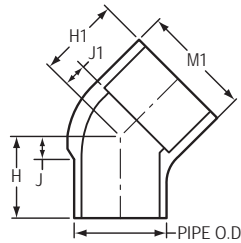

Part Number	Size	H	H1	J	J1	M1	Approx. Wt. (Lbs.)
427-005	1/2	1-9/32	1-9/32	11/32	13/32	1-3/16	.06
427-007	3/4	1-1/2	1-17/32	7/16	17/32	1-13/32	.09
427-010	1	1-19/32	1-21/32	13/32	17/32	1-23/32	.10
427-012	1-1/4	1-25/32	1-29/32	1/2	21/32	2-3/32	.22
427-015	1-1/2	2-1/32	2-3/32	19/32	23/32	2-11/32	.19
427-020	2	2	2	5/8	15/32	2-23/32	.30
427-025	2-1/2	2-5/8	2-5/8	3/4	7/8	3-11/32	.59
427-030	3	2-31/32	3-1/32	1	1-7/32	4-5/32	1.19
427-040	4	3-21/32	3-13/16	1-9/32	1-9/16	5-3/16	2.07
427-050	5	6-1/8	4-3/8	2-7/8	1-3/8	6-1/16	3.49
427-060	6	5-1/4	6-1/4	1-3/4	3	7-5/8	6.16
427-080	8	6-5/8	5-31/32	2-19/32	1-3/4	9-3/4	10.60