

EV 130

INDOOR UNIT

Energy Recovery Ventilator Standard



Download specification at:
renewaire.com/specifications

SPECIFICATIONS

Ventilation Type:
Static plate, heat and humidity transfer

Typical Airflow Range: 50-140 CFM

Unit is HVI Tested/Certified per CSA C439
Protocol: Using one L-50-G5 Core

Standard Features:
White painted cabinet
Line-cord power supply
Low-voltage circuit for controls
Unit may be mounted in any orientation
Cross-core differential pressure ports

Controls:
Onboard 24 VAC transformer/relay package with switched dry contacts

Filters:
Total qty. 2, MERV 8, spun-polyester media:
10 1/2" x 10 1/2" x 1"

Unit Dimensions & Weight:
33 1/2" L x 13 1/4" W x 20" H
48 lbs.

Max. Shipping Dimensions & Weight (in carton):
32" L x 22" W x 18" H
60 lbs.

Motor(s):
Qty. 1, Double-shaft standard motor

Accessories:
Backdraft damper 6", 8"
Automatic balancing damper 4", 5", 6"
Louvered wall vent 6" - white, brown
Digital time clock - wall mount (TC7D-W),
in exterior enclosure (TC7D-E)
Carbon dioxide sensor/control - wall mount (CO2-W),
duct mount (CO2-D)
IAQ sensor - wall mount (IAQ-W), duct mount (IAQ-D)
Motion occupancy sensor/control -
ceiling mount (MC-C), wall mount (MC-W)
Percentage timer control (PTL)
Push-button point-of-use controls (PBL), PTL req'd.
Percentage timer control with furnace interlock (FM)
Dehumidistat control (DH24)
MERV 13 filter - OA airstream (shipped loose)
Electric duct heater - RH series (1-5 kW);
designed for indoor ductwork installation only

Note: Indirect Gas-Fired Duct Furnace is not available on the EV130.

ELECTRICAL DATA

HP	Volts	HZ	Phase	Input Watts	FLA
0.1	120	60	Single	102 @ 130 CFM	1.3

UNIT PERFORMANCE

Airflow CFM	ESP in H ₂ O
78	0.60
104	0.50
125	0.40
136	0.30
153	0.20
163	0.10

CORE PERFORMANCE

Airflow CFM	Temp EFF%	Total EFF% Winter/Summer*
78	78	73/59
104	75	69/54
125	72	66/50
136	71	64/48
153	68	61/45
163	67	59/42

Note: These are core-only ratings and are not HVI certified.
HVI ratings apply to complete units only.
See HVI certification ratings on pg. 30 of Single/Multi-Family Catalog.

UNIT DIMENSIONS



AIRFLOW ORIENTATION
Available as shown in dimension drawing.



UNIT MOUNTING & APPLICATION
Can be mounted in any orientation. RA/OA airstream can be switched with OA/FA airstream.

ABBREVIATIONS
EA: Exhaust Air to outside
OA: Outside Air intake
RA: Room Air to be exhausted
FA: Fresh Air to inside

INSTALLATION ORIENTATION
Unit may be installed in any orientation.

NOTE
1. UNLESS OTHERWISE SPECIFIED, DIMENSIONS ARE ROUNDED TO THE NEAREST EIGHTH OF AN INCH.
2. SPECIFICATIONS MAY BE SUBJECT TO CHANGE WITHOUT NOTICE.

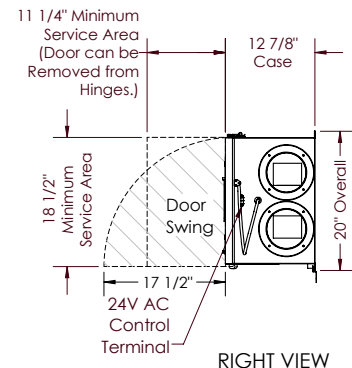
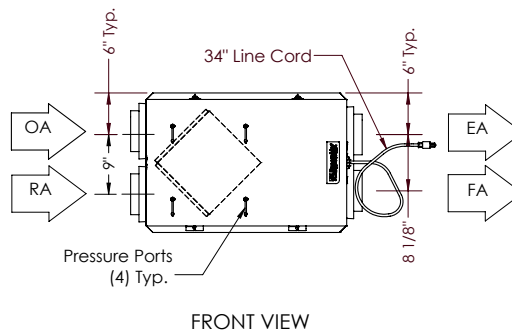
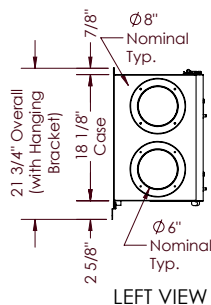
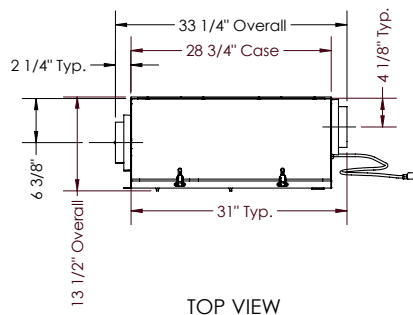

Specifications may be subject to change without notice.