

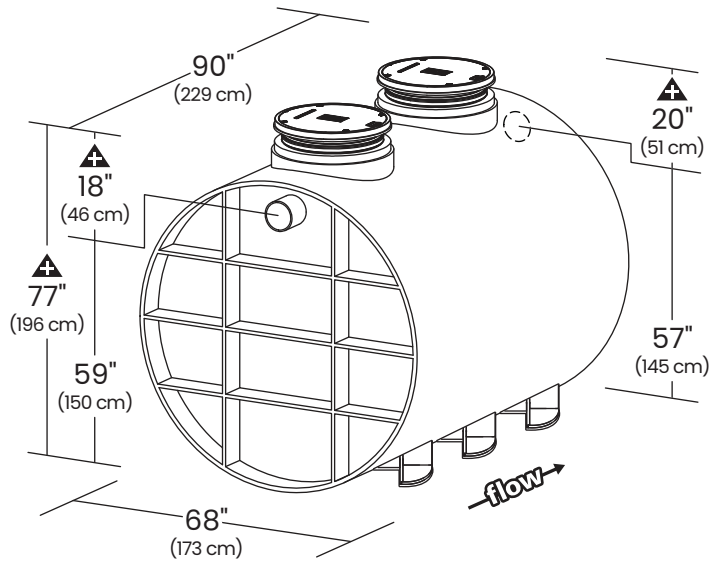

SPECIFICATION AND SUBMITTAL

GB-1000

100 GPM 99% Efficient Great Basin™
Indoor/Outdoor Grease Interceptor



 Adjustable cover adapters provide up to 4" of additional height.

 This unit is certified to ASME A112.14.3 (Type C) and CSA B481.1 and includes an internal flow control. External flow control with vent not required.

 Satisfies Miami DERM 99% efficiency requirements. Product labels are permanently attached to inside and outside of unit for easy viewing.

Includes Safety Star®

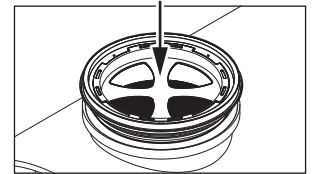

SUBMITTAL

Standard

Location: Indoor/outdoor

Installation: Below grade only

Flow Rates / Certified Grease Capacities:

100 GPM (6.3 L/s) / 6,547 lbs. (2,970 kg), 897 gal. (3,396 L)

Removal Efficiency at the Rated Capacity: 98.8%

99% Efficiency Rating: 6,237 lbs. (2,829 kg), 854 gal. (3,233 L) certified grease capacity @ 99.0% efficiency

Solids Capacity: 103 gal. (389.9 L)

Liquid Capacity: 1,010 gal. (3,823.3 L)

Weight: 1,516 lbs. (687.6 kg)

Connections: 6" plain end inlet/outlet

Covers: Cast iron covers, pickable 24" gas/water tight, H-20 rated, proof-load tested to 40,000 lbs.

Access Restrictor: Safety Star® (450 lb. rating) built into each cover adapter

Options

- 6" MPT inlet/outlet (stainless steel)
- 4" FPT inlet/outlet with 4" plain end adapters
- C24H2** Composite covers, bolted 24" gas/water tight, traffic load rated for 16,000 lbs.

Accessories

- FCR2 (x2)** >4" – 34" field cut risers
- FCR2 (x4)** >34" – 64" field cut risers
- FCR2 (x6)** >64" – 94" field cut risers
- CA2** Adapter for 24" corrugated pipe riser
- AK3** High Water Anchor Kit
- CC2** Integral membrane clamping collar kit

Approval

Signature:	Date:	Company:
Specifying Engineer:	Engineering Firm:	



SCHIER

MODEL NUMBER:
GB-1000

DESCRIPTION: 100 GPM Polyethylene Grease Interceptor – 1,010 gallon capacity

PART #: 4080-002-01

DWG BY: B. Karrer

DATE: 4/1/2021

REV:

ECO:



SPECIAL PRECAUTIONS

For Schier Grease Interceptor Installations – Failure to follow this guidance voids your warranty

WARNING! DO NOT AIR TEST UNIT OR RISER SYSTEM!
Doing so may result in property damage, personal injury or death.

CAUTION! Do not install this unit in any manner except as described in these instructions.

Installation Instructions

Installation instructions and additional components are included with the interceptor. Read all instructions prior to installation. This interceptor is intended to be installed by a licensed plumber in conformance with all local codes.

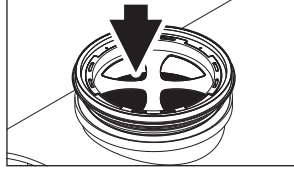

Hydrostatic/ Pressure Slabs

When installed under a hydrostatic slab (slab designed to withstand upward lift, usually caused by hydrostatic pressure) interceptor must be enclosed in a watertight concrete vault.

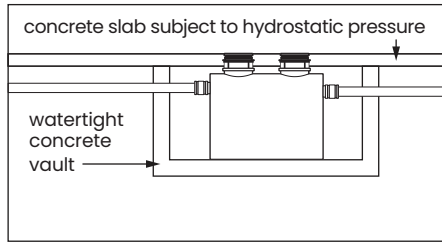

ODOR ALERT!

Interceptor is not a sewer gas trap. All upstream fixtures must be trapped.

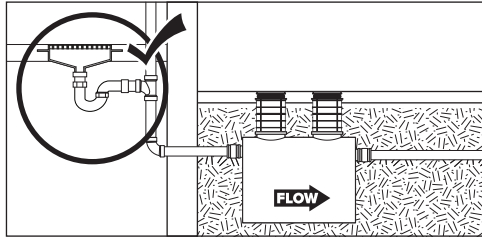

DO NOT INSTALL ABOVE GRADE

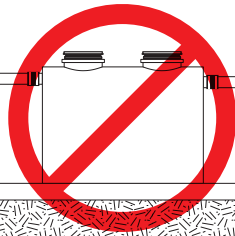

High Water Table Installations

Interceptors and risers are not designed to withstand water table height in excess of the top of the unit when buried (see figure). If it is possible for this to occur, install the interceptor and risers in a water-tight concrete vault or backfill with concrete or flowable fill (wet concrete and flowable backfill should be poured in stages to avoid crushing the interceptor). At risk areas include but are not limited to tidal surge areas, floodplains and areas that receive storm water. Great Basin™ models that are direct buried in high water table scenarios must be installed with an anchor kit. Model GB-1000 uses model AK3 anchor kit for use with deadmen anchors.

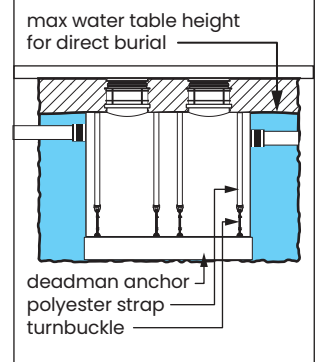

Below Grade Installation Slab Requirements

A concrete slab to finished grade with rebar is required when installing interceptor below grade.

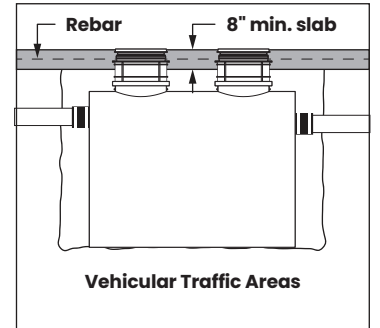
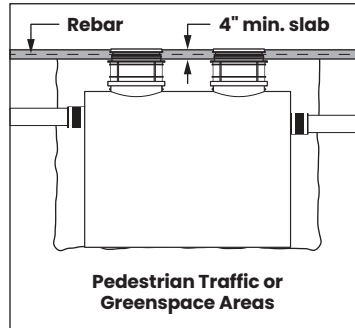

SCHIER

MODEL NUMBER:
GB-1000

DESCRIPTION: 100 GPM Polyethylene Grease Interceptor – 1,010 gallon capacity

PART #: 4080-002-01

DWG BY: B. Karrer

DATE: 4/1/2021

REV:

ECO:



SPECIAL PRECAUTIONS

For Schier Grease Interceptor Installations – Failure to follow this guidance voids your warranty

Indirect Connections

If your dishwashing sink(s) discharges into a floor drain/sink (drain), you must regulate the flow into the drain to avoid an overflow of water onto the kitchen floor. This can be done by

installing a valve or flow restriction cap on the sink piping that discharges into the drain. See drawing for guidance.

For detailed guidance on indirect connections, go to: webtools.schierproducts.com/Technical_Data/Indirect_Connections.pdf

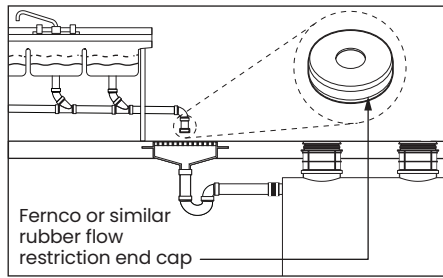

DO NOT COMPACT BACKFILL MECHANICALLY

Compact by hand only

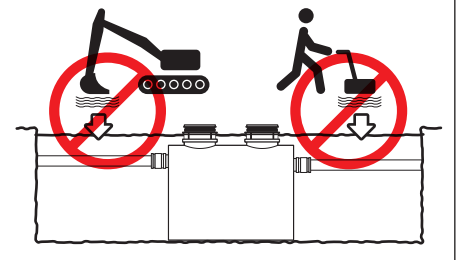

High Temperature Kitchen Water

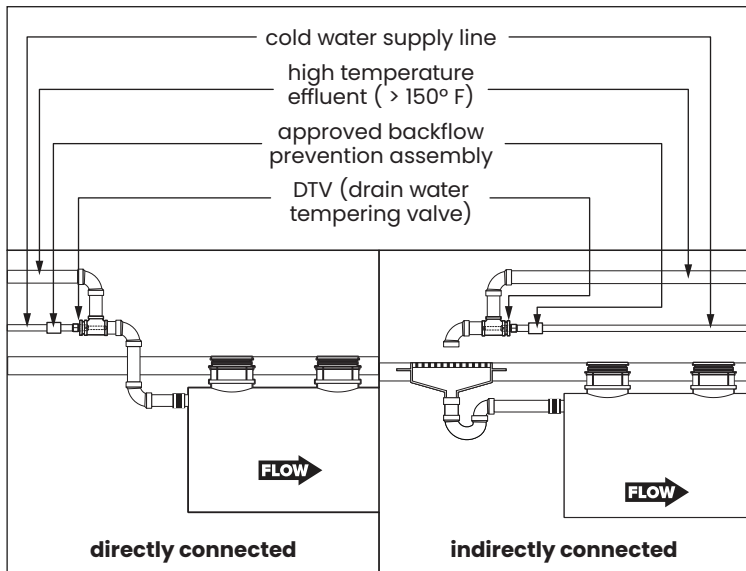

If water is entering the interceptor at excessive temperature (over 150° F), a drain water tempering valve (DTV) and approved backflow prevention assembly must be installed. Most state and local plumbing codes prohibit water above 150° F being discharged into the sanitary sewer. Water above 150° F will weaken or deform PVC Schedule 40 pipe, poly drainage fixtures like interceptors and erode the coating of cast iron (leading to eventual failure).

Installations with Risers

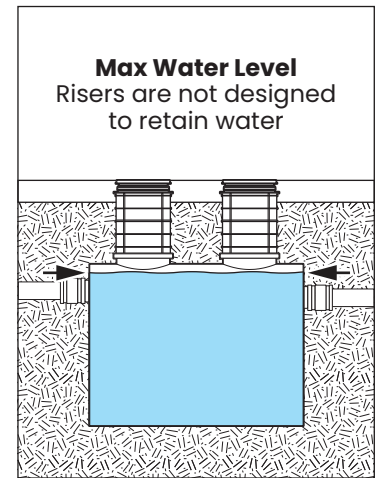
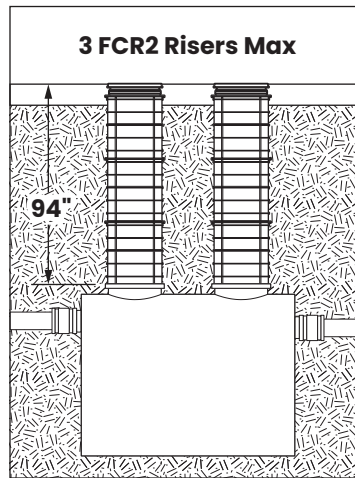

Corrugated Riser Pipe Requirements

Riser adapter model CA2 must be used when installing interceptors using 24" diameter corrugated pipe as a riser. This will adequately embed the cover adapter in the concrete slab, preventing cover/cover adapter failure under traffic rated loads.

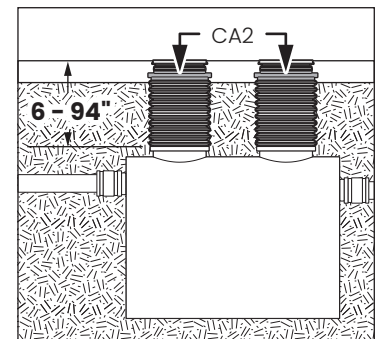

SCHIER

MODEL NUMBER:
GB-1000

DESCRIPTION: 100 GPM Polyethylene Grease Interceptor – 1,010 gallon capacity

PART #: 4080-002-01

DWG BY: B. Karrer

DATE: 4/1/2021

REV:

ECO:

SPECIFICATIONS

NOTES

- 6" plain end inlet/outlet
- Unit weight - w/composite covers: 1,400 lbs.; w/cast iron covers: 1,516 lbs. (for wet weight add 8,413 lbs.)
- Maximum operating temperature: 150° F continuous
- Capacities - Liquid: 1,010 gal.; Grease: 6,547 lbs. (894 gal.) Solids: 103 gal.
- Satisfies Miami DERM 99% efficiency requirements; retaining 6,237 lbs. (854 gal.) of grease at 99.0% efficiency.
- Built-in Flow control. For series installations, only install flow control on the first unit in the series if necessary.
- For gravity drainage applications only.
- Do not use for pressure applications.
- Cover placement allows full access to tank for proper maintenance.
- Vent not required unless per local code.
- Engineered inlet and outlet diffusers with inspection ports are removable to inspect / clean piping. For series installations, the top of the inlet diffuser on the first unit in the series must be sealed.
- Integral air relief / Anti-siphon / Sampling access.
- Adjustable cover adapters provide up to 4" of additional height.
- Flow rates are based on 2-minute drain time.
- Safety Star®, access restrictor built into each cover adapter, prevents accidental entry to tanks (450 lb rating).

ENGINEER SPECIFICATION GUIDE

Schier Great Basin™ grease interceptor model # GB-1000 shall be lifetime guaranteed and made in USA of seamless, molded polyethylene with minimum 3/4" uniform wall thickness. Interceptor shall be furnished for below-grade installation with adjustable cover adapter and Safety Star® access restrictor built into each cover adapter. Interceptor shall be certified to ASME A112.14.3 (Type C) and CSA B481.1. Interceptor flow rate shall be 100 GPM. Interceptor grease capacity shall be 6,237 lbs. Cover shall provide water/gas-tight seal and have minimum 16,000 lbs. load capacity.

CERTIFIED PERFORMANCE

Great Basin™ hydromechanical grease interceptors are third party performance-tested and listed by IAPMO to ASME #A112.14.3 and CSA B481.1 grease interceptor standards and greatly exceed requirements for grease separation and storage. They are compliant to the Uniform Plumbing Code and the International Plumbing Code.

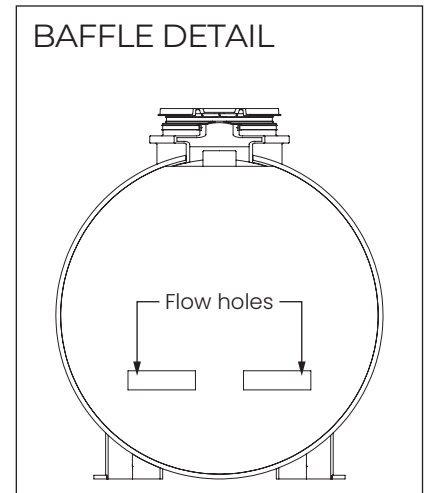
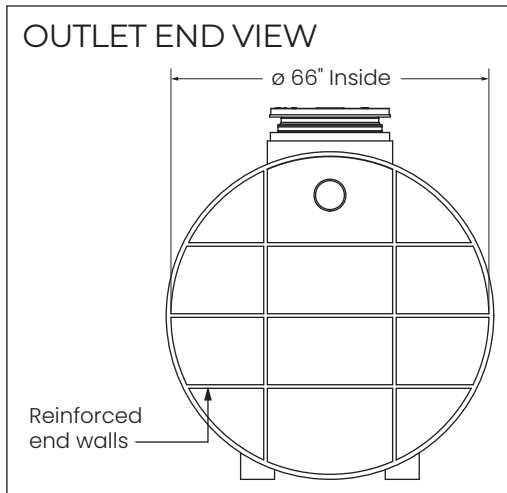
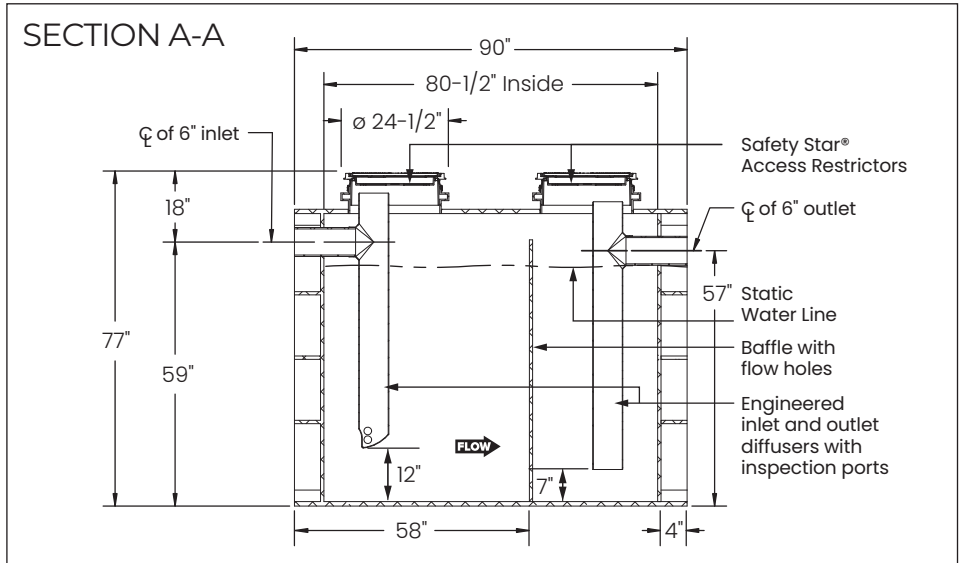
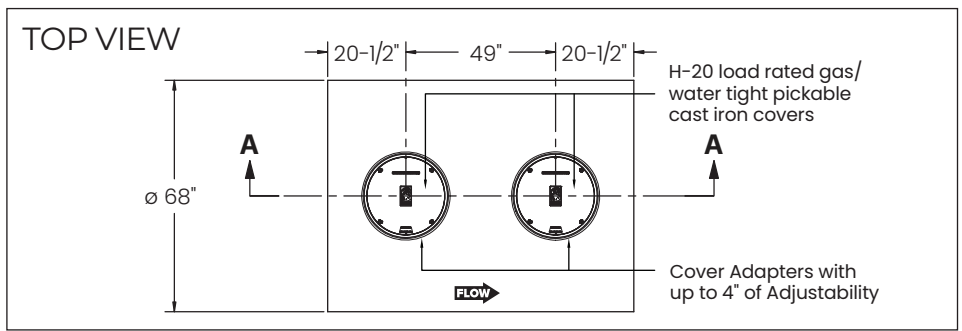

Rated Grease Capacities for Units Piped in Series

No. of Units In Series	Removal Efficiency	
	100 GPM - 98.8%	100 GPM - 99%
2	13,094 lbs.	12,474 lbs.
3	19,641 lbs.	18,711 lbs.
4	26,188 lbs.	24,948 lbs.



SCHIER

MODEL NUMBER:
GB-1000

DESCRIPTION: 100 GPM Polyethylene Grease Interceptor - 1,010 gallon capacity

PART #: 4080-002-01

DWG BY: B. Karrer

DATE: 4/1/2021

REV:

ECO: