

Series 211A™

Gas Boilers – Steam



Installation, Operation & Maintenance Manual



PeerlessBoilers.com

TABLE OF CONTENTS

USING THIS MANUAL	1	8. INSTALL CONTROLS & TRIM	33
A. FOLLOW THE PIPING GUIDELINES.	1	A. INSTALL SAFETY VALVE(S)	33
B. CONTROLS.	1	B. INSTALL BLOWDOWN VALVES.	33
C. SPECIAL ATTENTION BOXES.	1	C. INSTALL LOW WATER CUT-OFF(S).	33
1. PREINSTALLATION	2	D. INSTALL PRESSURE CONTROLS	33
A. ACCESSIBILITY CLEARANCES	2	9. WIRE THE BOILER	38
B. COMBUSTIBLE CONSTRUCTION CLEARANCES	2	A. CONNECT SUPPLY WIRING.	38
C. AIR FOR COMBUSTION & VENTILATION	2	B. PREPARE REMAINING CONTROLS.	38
D. CHIMNEY OR VENT.	5	C. INSTALL CONTROL WIRING	38
E. BOILER SETTING	7	10. STARTING THE BOILER	43
F. WATER QUALITY AND MAKE-UP.	8	A. CHECK THE PIPING	43
G. INSTALLATION SURVEY.	8	B. FILL THE BOILER	43
2. ASSEMBLE THE BASE	10	C. STUDY LIGHTING INSTRUCTIONS	43
A. BASE ASSEMBLY	10	D. RUN PILOT CHECK-OUT	43
B. INSTALL THE PILOT BURNERS	11	E. CHECK MAIN BURNER SYSTEM	43
3. PLACE THE BOILER SECTIONS	15	F. CHECK BOILER CONTROLS	44
A. PREPARATION	15	G. CLEAN THE BOILER	44
B. PLACING THE SECTIONS.	15	11. OPERATING INSTRUCTIONS - TYP.	45
C. HYDROSTATIC TEST THE BOILER	17	12. OPERATION & MAINTENANCE	47
4. INSTALL THE FLUE COLLECTOR	18	A. PLACING BOILER IN OPERATION	48
5. PIPE THE BOILER	20	B. TO SHUT DOWN THE BOILER.	48
A. PREPARATION	20	C. ANNUAL MAINTENANCE	49
B. SUPPLY PIPING	20	D. MONTHLY MAINTENANCE.	49
C. RETURN PIPING.	20	E. WEEKLY MAINTENANCE.	49
D. MULTIPLE BOILER INSTALLATIONS	22	F. DAILY MAINTENANCE.	49
6. INSTALL THE JACKET & DRAFT HOOD	24	G. AUTOMATIC SAFETY SHUTOFF VALVE LEAKAGE TESTS.	49
A. PREPARE THE PARTS.	24	13. TROUBLESHOOTING - SERVICE TIPS	52
B. APPLY CLEANOUT COVER PLATES.	24	14. BOILER RATINGS & DIMENSIONS	54
C. APPLY JACKET END ASSEMBLIES.	24	15. REPAIR PARTS - SERIES 211A™	58
D. 211A™-04 THROUGH 211A™-08 ONLY.	24		
E. 211A™-09 AND LARGER ONLY.	24		
F. APPLY JACKET TOP PANELS	25		
G. APPLY LOWER END PANELS.	25		
H. APPLY PLATES AND LABELS	25		
7. CONNECT GAS PIPING	30		
A. INSTALL GAS TRAIN	30		
B. CONNECT PILOT GAS TUBING	30		
C. INSTALL VENT AND BLEED PIPING	30		
D. INSTALL GAS SUPPLY PIPING	31		
E. TEST GAS SUPPLY PIPING.	31		

USING THIS MANUAL

A. FOLLOW THE PIPING GUIDELINES

1. We have provided suggested piping diagrams which will cover most applications of this boiler.
2. Follow these guidelines to make sure the boiler will operate correctly.

B. CONTROLS

1. This manual provides wiring diagrams and lighting instructions for standard systems only.
2. Use the Lighting Instructions and Wiring Diagrams provided with the boiler to make sure they represent the controls provided.

C. SPECIAL ATTENTION BOXES

1. Throughout this manual you will see special attention boxes intended to supplement the instructions and make special notice of potential hazards. These categories mean, in the judgment of PB Heat, LLC:

DANGER

Indicates a hazardous situation, which, if not avoided, will result in death or serious injury and major property damage.

WARNING

Indicates a hazardous situation, which, if not avoided, could result in death or serious injury and major property damage.

CAUTION

Indicates a hazardous situation, which, if not avoided, could result in minor or moderate injury, and minor property damage.

NOTICE

Indicates special attention is needed, not related to personal injury or property damage.

1. PREINSTALLATION

Read carefully, study these instructions before beginning work. It will save time. Study the included drawings. Save these instructions for reference.

⚠ WARNING

This manual is intended for use by Qualified Heating Professionals only. Installation, service, or adjustment of this heating appliance by anyone other than a Qualified Heating Professional may cause severe personal injury, death, or major property damage.

The boiler warranty can be voided if the boiler is not installed, maintained and serviced correctly.

NOTICE

The equipment shall be installed with those installation requirements of the authority having jurisdiction or, in the absence of such requirements, to the current edition of the *National Fuel Gas Code*, ANSI Z223.1/NFPA 54 and/or CAN/CGA B149 Installation Codes.

Where required by the authority having jurisdiction, the installation must conform to *American Society of Mechanical Engineers Safety Code for Controls and Safety Devices for Automatically Fired Boilers*, ASME CSD-1.

A shipping list is enclosed with each boiler, listing the items packed at the factory. Check the list as you unpack parts. If any parts are missing or damaged, report the problem to the delivering carrier immediately.

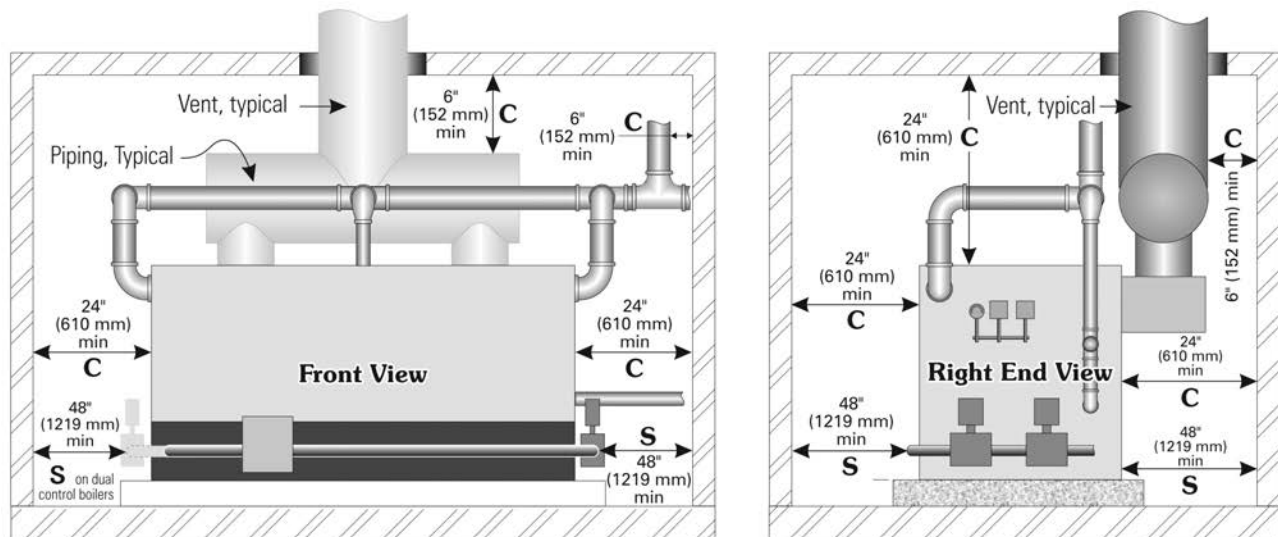

Figure 1.1: Clearance Requirements

A. ACCESSIBILITY CLEARANCES

1. The following recommendations allow for *reasonable access to the boiler*. Local codes or special conditions may require greater clearances.
 - a. For servicing the boiler: provide 48" (1219 mm) between the control manifold and adjacent wall or other appliance.
 - b. For access to draft hood or passage to access the boiler control manifold(s): provide 48" (1219 mm) between the side of the boiler and adjacent wall or other appliance.
 - c. See Figure 1.1. Clearances with an "S" are minimum clearances for service accessibility.

B. COMBUSTIBLE CONSTRUCTION CLEARANCES

1. This boiler is design certified for the following *clearances to combustible construction*.
 - 24" (610 mm) between the front, top, sides and rear of the jacket.
 - 6" (152 mm) from steam and hot water pipes
 - 6" (152 mm) from vent connector
 - See Figure 1.1. Clearances with a "C" indicate minimum clearances from combustible construction.

C. AIR FOR COMBUSTION AND VENTILATION

1. Adequate combustion air and ventilation air must be provided for this appliance in accordance with the section of the *National Fuel Gas Code* entitled, "Air for Combustion and Ventilation" or applicable provisions of the local building code. Subsections 2 through 8 as follows are based on the *National Fuel Gas Code* requirements.
2. **Required Combustion Air Volume:** The total required volume of indoor air is to be the sum of the required volumes for all appliances located within the space. Rooms communicating directly with the space in which the appliances are installed and through combustion air openings sized as indicated in Subsection 3 are considered part of the required volume. The required volume of indoor air is to be determined by one of two methods.

a. **Standard Method:** The minimum required volume of indoor air (room volume) shall be 50 cubic feet per 1000 BTU/Hr (4.8 m³/kW). This method is to be used if the air infiltration rate is unknown or if the rate of air infiltration is known to be greater than 0.6 air changes per hour. As an option, this method may be used if the air infiltration rate is known to be between 0.6 and 0.4 air changes per hour. If the air infiltration rate is known to be below 0.4 then the *Known Air Infiltration Rate Method* must be used. If the building in which this appliance is to be installed is unusually tight, PB Heat recommends that the air infiltration rate be determined.

b. **Known Air Infiltration Rate Method:** Where the air infiltration rate of a structure is known, the minimum required volume of indoor air for appliances other than fan assisted and for the Series 211A™ Boiler shall be determined as follows:

$$\text{Required Volume}_{\text{other}} = \frac{21 \text{ ft}^3}{\text{ACH}} \left(\frac{I_{\text{other}}}{1000^{\text{Btu/hr}}} \right)$$

where:

I_{other} = Input of appliances other than fan assisted in Btu/hr

ACH = air change per hour (percent of the volume of the space exchanged per hour, expressed as a decimal)

For fan assisted appliances, calculate the required volume of air using the following equation:

$$I_{\text{fan}} = \text{Input of the fan assisted appliances in Btu/hr}$$

$$\text{Required Volume}_{\text{fan}} = \frac{15 \text{ ft}^3}{\text{ACH}} \left(\frac{I_{\text{fan}}}{1000^{\text{Btu/hr}}} \right)$$

Note:

These calculations are not to be used for infiltration rates greater than 0.60 ACH.

3. **Indoor Air Opening Size and Location:** Openings connecting indoor spaces shall be sized and located as follows:

- a. **Combining spaces on the same floor:** Provide two permanent openings communicating with additional spaces that have a minimum free area of 1 in² per 1000 Btu/hr (22 cm² per 1000 W) of the total input rating of all gas fired equipment but not less than 100 in² (645 cm²). One opening is to begin within 12 inches (305 mm) from the top of the space and the other is to begin within 12 inches (305 mm) from the floor. The minimum dimension of either of these openings shall be 3 inches (76 mm). See Figure 1.2 for an illustration of this arrangement.

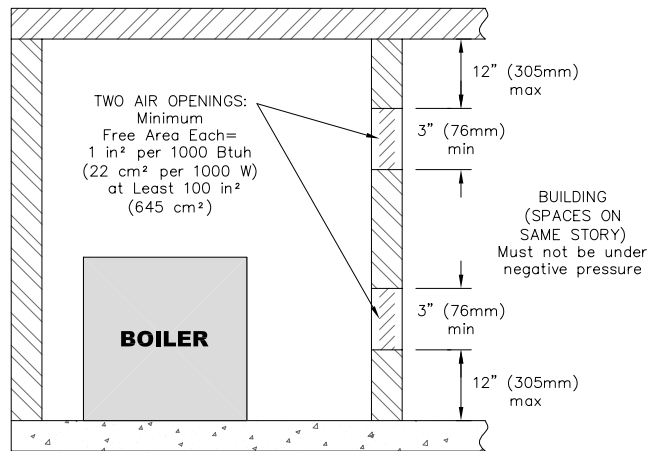

Figure 1.2: Air Openings – All Air from Indoors on the Same Floor

- b. **Combining spaces on different floors:** Provide one or more permanent openings communicating with additional spaces that have a total minimum free area of 2 in² per 1000 Btu/hr (44 cm² per 1000 W) of total input rating of all equipment. See Figure 1.3 for an illustration of this arrangement.

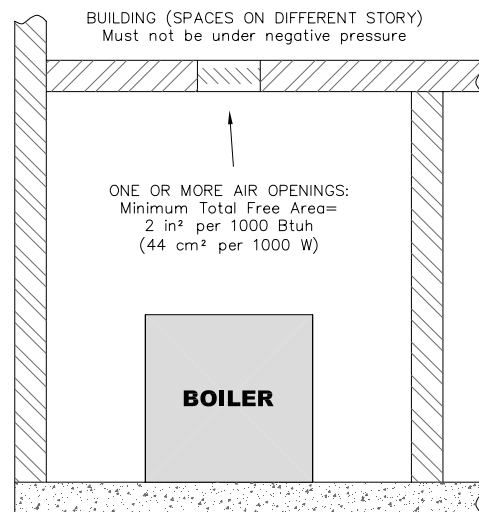

Figure 1.3: Air Openings – All Air from Indoors on Different Floors

4. **Outdoor Combustion Air:** Outdoor combustion air is to be provided through one or two permanent openings. The minimum dimension of these air openings is 3 inches (76 mm).

a. **Two Permanent Opening Method:** Provide two permanent openings. One opening is to begin within 12 inches (305 mm) of the top of the space and the other is to begin within 12 inches (305 mm) of the floor. The openings are to communicate directly or by ducts with the outdoors or with spaces that freely communicate with the outdoors. The size of the openings shall be determined as follows:

- i. Where communicating directly or through vertical ducts with the outdoors each opening shall have a minimum free area of 1 in² per 4000 Btu/hr (22 cm² per 4000 W) of total input rating for all equipment in the space. See Figure 1.4 for openings directly communicating with the outdoors or Figure 1.5 for openings connected by ducts to the outdoors.
- ii. Where communicating with the outdoors through horizontal ducts, each opening shall have a minimum free area of 1 in² per 2000 Btu/hr (22 cm² per 2000 W) of total rated input for all appliances in the space. See Figure 1.6.

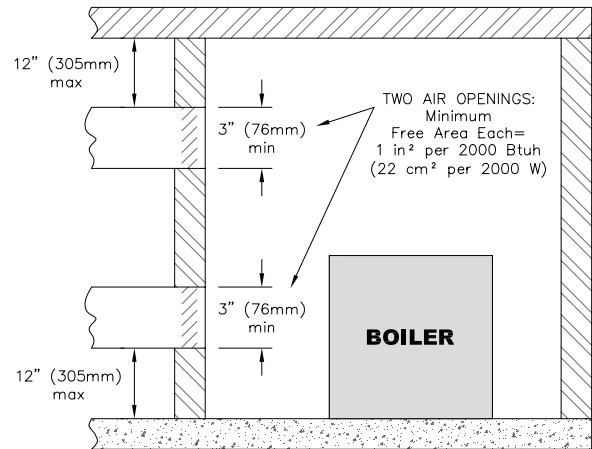

Figure 1.6: Air Openings – All Air from Outdoors through Horizontal Ducts

b. **One Permanent Opening Method:** Provide one permanent opening beginning within 12 inches (305 mm) of the top of the space. The opening shall communicate directly with the outdoors, communicate through a vertical or horizontal duct, or communicate with a space that freely communicates with the outdoors. The opening shall have a minimum free area of 1 in² per 3000 Btu/hr of total rated input for all appliances in the space and not less than the sum of the cross-sectional areas of all vent connectors in the space. The gas-fired equipment shall have clearances of at least 1 inch (25 mm) from the sides and back and 6 inches (150 mm) from the front of the appliance. See Figure 1.7 for this arrangement.

5. **Combination Indoor and Outdoor Combustion Air:** If the required volume of indoor air exceeds the available indoor air volume, outdoor air openings or ducts may be used to supplement the available indoor air provided:

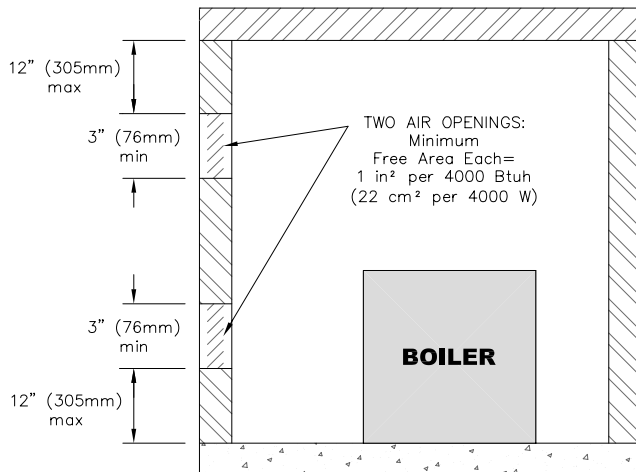

Figure 1.4: Air Openings – All Air Directly from Outdoors

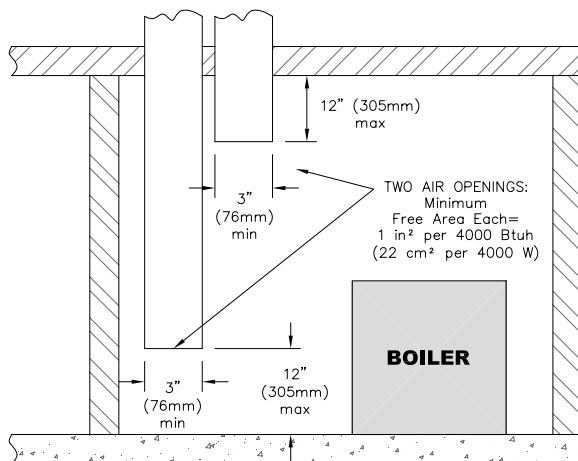

Figure 1.5: Air Openings – All Air from Outdoors through Vertical Ducts

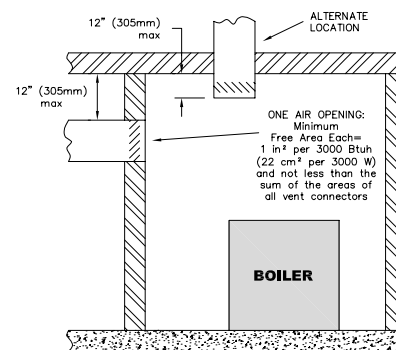

Figure 1.7: Air Openings – All Air from Outdoors through One Opening

- a. The size and location of the indoor openings comply with Subsection 3.
- b. The outdoor openings are to be located in accordance with Subsection 4.
- c. The size of the outdoor openings are to be sized as follows:

where:

A_{req} = minimum area of outdoor openings.

A_{full} = full size of outdoor openings calculated in accordance with Subsection 4.

V_{avail} = available indoor air volume

$$A_{req} = A_{full} \left(1 - \frac{V_{avail}}{V_{req}} \right)$$

V_{req} = required indoor air volume

6. **Engineered Installations:** Engineered combustion air installations shall provide an adequate supply of combustion, ventilation, and dilution air and shall be approved by the authority having jurisdiction.
7. **Mechanical Combustion Air Supply:**
 - a. In installations where all combustion air is provided by a mechanical air supply system, the combustion air shall be supplied from the outdoors at the minimum rate of 0.35 ft³/min per 1000 Btu/hr (0.034 m³/min per 1000 W) of the total rated input of all appliances in the space.
 - b. In installations where exhaust fans are installed, additional air shall be provided to replace the exhaust air.
 - c. Each of the appliances served shall be interlocked to the mechanical air supply to prevent main burner operation when the mechanical air supply system is not in operation.
 - d. In buildings where the combustion air is provided by the mechanical ventilation system, the system shall provide the specified combustion air rate in addition to the required ventilation air.
8. **Louvers & Grills:**
 - a. The required size of openings for combustion, ventilation, and dilution air shall be based on the net free area of each opening.
 - i. Where the free area through a louver or grille is known, it shall be used in calculating the opening size required to provide the free area specified.
 - ii. Where the free area through a louver or grille is not known, it shall be assumed that wooden louvers will have 25% free area and metal louvers and grilles will have 75% free area.
 - iii. Nonmotorized dampers shall be fixed in the open position.
9. **Combustion Air Ducts**
 - a. Ducts shall be constructed of galvanized steel or an equivalent corrosion-resistant material.
 - b. Ducts shall terminate in an unobstructed space, allowing free movement of combustion air to the appliances.
 - c. Ducts shall serve a single space.
 - d. Ducts shall not serve both upper and lower combustion air openings where both such openings are used. The separation between ducts serving upper and lower combustion air openings shall be maintained to the source of combustion air.
 - e. Ducts shall not be screened where terminating in an attic space.
 - f. Horizontal upper combustion air ducts shall not slope downward toward the source of the combustion air.
 - g. The remaining space surrounding a chimney liner, gas vent, special gas vent, or plastic piping installed within a masonry, metal, or factory built chimney shall not be used to supply combustion air.
 - h. Combustion air intake openings located on the exterior of buildings shall have the lowest side of the combustion air intake opening at least 12 inches (305 mm) above grade.
10. **Motorized dampers shall be interlocked with the equipment so that they are proven in the full open position prior to ignition and during operation of the main burner.**
 - i. The interlock shall prevent the main burner from igniting if the damper fails to open during burner startup.
 - ii. The interlock shall shut down the burner if the damper closes during burner operation.

D. CHIMNEY OR VENT

1. Inspect the existing chimney or vent system. Make sure it is in good condition. Inspect chimney liner and repair or replace if necessary.
2. The vent system and installation must be in accordance with the current edition of the *National Fuel Gas Code*, ANSI Z223.1/NFPA 54, under "Venting of Equipment", or CAN/CGA B149, Installation codes, under "Venting Systems and Air Supply for Appliances", or applicable provisions of the local building codes.

3. Chimney/Vent Operation: The vent system must be sized and installed to provide the draft needed to remove all combustion products. If the vent system does not provide enough draft, combustion products will spill into the building from the draft hood relief opening. If spillage of combustion products occurs, check the vent system, the combustion and ventilation openings and make sure the boiler room is never under negative pressure.

⚠ WARNING

Failure to provide adequate venting can result in severe property damage, personal injury or death.

4. Exterior Vents
 - a. If the vent is outside, make sure it is insulated sufficiently to ensure adequate draft.
5. Vent Sizing:
 - a. Individual vents: Use vent piping the same diameter as the boiler vent connection. The minimum height is 10 feet (305 cm) above the bottom of the draft hood (relief opening). The vent must also extend above the roof or any obstructions as outlined in the current edition of the *National Fuel Gas Code*, ANSI Z223.1/NFPA 54 and/or CAN/CGA B149, Installation Codes or as required by local codes.
 - b. Combined vent breeching:
 - The recommended sizing in Section 14, Boiler Ratings & Dimensions, in this Manual is based on a minimum chimney or vent height of 20 feet (610 cm) and a maximum horizontal run of 6 feet (183 cm) to the chimney with no more than one 90-degree standard elbow.

- The minimum area of the chimney serving two or more appliances must be at least the area of the largest chimney connector plus 50% of the total area of all other appliance connectors.
- The vent connector must be single wall steel or Type B double wall vent pipe. The vent connector must be Type B double wall if it is located in or passes through cold areas. The vent connector must extend into, but not beyond, the inside wall of the chimney.

6. Vent Connection to Boiler (Figure 1.8):
 - a. The vent system must provide a draft of at least 0.02" w.c. (5 Pa) measured within 12 inches of the draft hood outlet. A 3 foot (91 cm) rise from the draft hood outlet on the boiler to the centerline of the chimney breach is recommended.
 - b. Support the weight of the vent system independently of the boiler draft hood. The draft hood is not designed to carry structural loading.
 - c. Provide support of the vent connector (breeching) at maximum 12 foot (366 cm) intervals to prevent sagging and to provide a minimum upward slope of 1/4" per foot (21 mm per meter).
 - d. Do not connect the vent for this boiler into any vent system which operates with positive pressure.
 - e. Use Type B double-wall pipe for vents which run through unheated spaces.
7. Removing an existing boiler from a common vent: At the time for removal of an existing boiler, the following steps shall be followed with each appliance connected to the common venting system placed in operation, while the other appliances remaining connected to the common venting system are not in operation.
 - a. Seal any unused openings in the common venting system.

Sceller toute ouverture du système d'évacuation commun non utilisée.
 - b. Visually inspect the venting system for proper size and horizontal pitch and determine there is no blockage or restriction, leakage, corrosion and other deficiencies which could cause an unsafe condition.

Effectuer un contrôle visuel du système d'évacuation pour vérifier la taille et la pente horizontale et s'assurer qu'il n'existe aucun blocage ou obstruction, fuite, corrosion ni tout autre problème pouvant menacer la sécurité.
 - c. Insofar as is practical, close all building doors and windows and all doors between the space in which the appliances remaining connected to the common venting system are located and other spaces of the building. Turn on any clothes dryers and any appliance not connected to common venting system. Turn on any exhaust fans, such as range hoods and bathroom exhausts, so they will operate at maximum speed. Do not operate a summer exhaust fan. Close fireplace dampers.

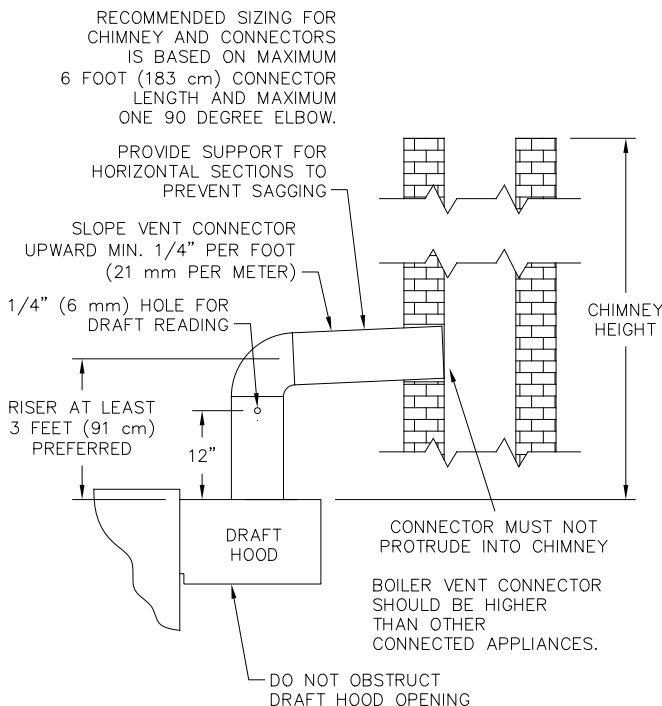

Figure 1.8: Vent Connection

Dans la mesure du possible, fermer toutes les portes et fenêtres de l'immeuble ainsi que toutes les portes entre l'espace dans lequel les appareils qui demeurent raccordés au système d'évacuation commun se trouvent et le reste de l'immeuble. Mettre en marche les sècheuses et tout autre appareil non raccordé au système d'évacuation commun. Mettre en marche tous les ventilateurs aspirant, tels que les hottes de cuisinière et les ventilateurs de salle de bain, en les faisant fonctionner à vitesse maximum. Ne pas faire fonctionner les ventilateurs aspirant d'été. Fermer les registres de foyers.

- d. Place in operation the appliance being inspected. Follow the lighting instructions. Adjust thermostat so appliance will operate continuously.

Mettre en service l'appareil à inspecter. Suivre les instructions concernant l'allumage. Régler le thermostat afin que l'appareil fonctionne sans arrêt.

- e. Test for spillage at the draft hood relief opening after 5 minutes of main burner operation. Use the flame of a match or candle, or smoke from a cigarette, cigar, or pipe.

Vérifier toute fuite à l'orifice de décharge du coupetirage après que le brûleur ait fonctionné pendant 5 minutes. Utiliser la flamme d'une allumette ou d'une chandelle ou encore la fumée d'une cigarette, d'un cigare ou d'une pipe.

- f. After it has been determined that each appliance remaining connected to the common venting system properly vents when tested as outlined above, return doors, windows, exhaust fans, fireplace dampers and any other gas-burning appliance to their previous conditions of use.

Après avoir établi que les résidus de combustion de chaque appareil qui demeure raccordé au système commun sont adéquatement évacués lorsque soumis au test décrit ci-dessus, remettre en place les portes, fenêtres, portes intérieures, ventilateurs aspirants, registres de foyer et appareils fonctionnant au gaz.

- g. Any improper operation of the common venting system should be corrected so that the installation conforms with the current edition of the *National Fuel Gas Code*, ANSI Z223.1/NFPA 54 and/or CAN/CSA B149.1, *Natural Gas and Propane Installation Code*. When resizing any portion of the common venting system, the common venting system should be resized to approach the minimum size as determined using the appropriate tables in the *National Fuel Gas Code*, ANSI Z223.1/NFPA 54 and/or CAN/CSA B149.1, *Natural Gas and Propane Installation Code*.

Tout fonctionnement inadéquat du système d'évacuation commun doit être corrigé de manière à respecter les normes du **National Fuel Gas Code**, ANSI Z223.1/NFPA 54 et/ou des Codes d'installation CAN/ACG B149. Lorsqu'il est nécessaire de modifier les dimensions de toute portion du système d'évacuation commun, ces dernières doivent être modifiées de manière à respecter les dimensions minimums indiquées dans les tableaux du chapitre « Sizing of Category I Venting Systems » du **National Fuel Gas Code**, ANSI Z223.1/NFPA 54 ou des Codes d'installation CAN/ACG B149.

E. BOILER SETTING

1. Provide a good, level foundation for the boiler with the minimum dimensions given in Figure 1.9 and Table 1.1. The flooring and structural support system must be suitable for the operating weight of the boiler and any connected piping.

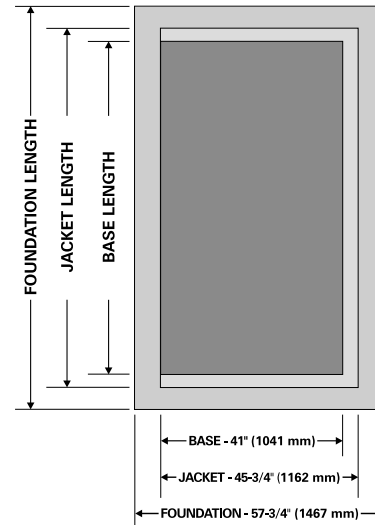

Figure 1.9: Foundation Layout

2. Do not operate the boiler until the foundation, if new concrete, has thoroughly cured. The high temperature under the burners could cause major damage to the concrete if it still contains moisture.

WARNING

Do not install this boiler on carpeting or any combustible flooring. A significant fire hazard could result, with potential for property damage, personal injury or death.

3. If the boiler is installed in a penthouse or if wiring of any sort is run underneath the boiler foundation, construct the foundation with provision for airflow underneath between the main floor and the top of the boiler foundation.
 - a. Concrete block aligned with the openings connected continuously would serve this purpose, for example.
 - b. If the foundation must be a concrete slab, use an air cell high temperature insulating board, at least 1/2 inch (13 mm) thick, with aluminum backing, aluminum side up. One-half inch (13 mm) Hi Temp millboard with aluminum backing would be acceptable as well. Place the insulating board on the slab inside the base.

F. WATER QUALITY AND MAKE-UP

1. Check the system to make sure there are no leaks or overfilling problems which might cause excessive make-up water to be added. Make-up water causes liming in the boiler and brings in oxygen. Oxygen can cause severe damage to the boiler through oxygen corrosion pitting.
2. Clean the boiler as described in this manual. Poor water quality will cause foaming, priming and overfilling of the system. Too much sediment in the water will cause build-up in the boiler and could result in cracked sections due to overheating.
3. If the condensate return time lag is too long, this boiler may not work correctly with gravity return or with a condensate return unit. Long time lags will cause make-up water to be added to the boiler, resulting in flooding of the boiler, carryover to the system and excessive make-up water addition. You will need to install a boiler feed system to prevent problems in such cases.
4. **Do not use chemicals or substances in the boiler or system which contain petroleum or its derivatives. This will damage the boiler seals.**

G. INSTALLATION SURVEY

For new and existing installations, a Steam Installation Survey is available from PB Heat. The survey will provide information on how a steam boiler works with your specific system and will provide an overview of steam system operation in general.

You can also use this survey to locate system problems which will have to be corrected. To obtain copies of the Steam Installation Survey, contact your Peerless® representative or download from PeerlessBoilers.com.

Table 1.1: Boiler Foundation Layout

Boiler Model	Boiler Base Length		Jacket Length		Foundation Length	
	inches	mm	inches	mm	inches	mm
211A-04	22-1/2	572	28-1/8	714	40-1/8	1,019
211A-05	28-1/8	714	33-3/4	857	45-3/4	1,162
211A-06	33-3/4	857	39-3/8	1,000	51-3/8	1,305
211A-07	39-3/8	1,000	45	1,143	57	1,448
211A-08	45	1,143	50-5/8	1,286	62-5/8	1,591
211A-09	50-5/8	1,286	56-1/4	1,429	68-1/4	1,734
211A-10	56-1/4	1,429	61-7/8	1,572	73-7/8	1,876
211A-11	61-7/8	1,572	67-1/2	1,714	79-1/2	2,019
211A-12	67-1/2	1,714	73-1/8	1,857	85-1/8	2,162
211A-13	73-1/8	1,857	78-3/4	2,000	90-3/4	2,305
211A-14	78-3/4	2,000	84-3/8	2,143	96-3/8	2,448
211A-15	84-3/8	2,143	90	2,286	102	2,591
211A-16	90	2,286	95-5/8	2,429	107-5/8	2,734
211A-17	95-5/8	2,429	101-1/4	2,572	113-1/4	2,877
211A-18	101-1/4	2,572	106-7/8	2,715	118-7/8	3,019
211A-19	106-7/8	2,715	112-1/2	2,857	124-1/2	3,162
211A-20	112-1/2	2,857	118-1/8	3,000	130-1/8	3,305
211A-21	118-1/8	3,000	123-3/4	3,143	135-3/4	3,448
211A-22	123-3/4	3,143	129-3/8	3,286	141-3/8	3,591
211A-23	129-3/8	3,286	135	3,429	147	3,734
211A-24	135	3,429	140-5/8	3,572	152-5/8	3,877
211A-25	140-5/8	3,572	146-1/4	3,715	158-1/4	4,020
211A-26	146-1/4	3,715	151-7/8	3,858	163-7/8	4,162
211A-27	151-7/8	3,858	157-1/2	4,000	169-1/2	4,305
211A-28	157-1/2	4,000	163-1/8	4,143	175-1/8	4,448
211A-29	163-1/8	4,143	168-3/4	4,286	180-7/8	4,594
211A-30	168-3/4	4,286	174-3/8	4,429	186-3/8	4,734
211A-31	174-3/8	4,429	180	4,572	192	4,877
211A-32	180	4,572	185-5/8	4,715	197-5/8	5,020
211A-33	185-5/8	4,715	191-1/4	4,858	203-1/4	5,163
211A-34	191-1/4	4,858	196-7/8	5,001	208-7/8	5,305
211A-35	196-7/8	5,001	202-1/2	5,143	214-1/2	5,448
211A-36	202-1/2	5,143	208-1/8	5,286	220-1/8	5,591
211A-37	208-1/8	5,286	213-3/4	5,429	225-3/4	5,734
211A-38	213-3/4	5,429	219-3/8	5,572	231-3/8	5,877
211A-39	219-3/8	5,572	225	5,715	237	6,020
211A-40	225	5,715	230-5/8	5,858	242-5/8	6,163
211A-41	230-5/8	5,858	236-1/4	6,001	248-1/4	6,306
211A-42	236-1/4	6,001	241-7/8	6,144	253-7/8	6,448
211A-43	241-7/8	6,144	247-1/2	6,286	259-1/2	6,591
211A-44	247-1/2	6,286	253-1/8	6,429	265-1/8	6,734
211A-45	253-1/8	6,429	258-3/4	6,572	270-3/4	6,877
211A-46	258-3/4	6,572	264-3/8	6,715	276-3/8	7,020

2. ASSEMBLE THE BASE

A. BASE ASSEMBLY

1. Collect the crates containing the Base Assembly parts. Table 2.1 (on page 11) shows the quantity of each crate required. The crates contain the following parts:

Crate	Items	Sub-Assembly #	Part #
2	Right End Panel Sub-Assembly	90338	GG-2105
	Left End Panel Sub-Assembly		GG-2106
	Burner Support Channel Clips (2)		GG-2070
2AA	Front Panel Sub-Assembly	90340	GG-2080
	Back Panel Sub-Assembly		GG-2081
	Burner Support Channel		GG-2066
	Front Panel Support Bracket		GG-2069
	Section Assembly Kit		GG-1030
2BB	Front Panel Sub-Assembly	90341	GG-2080-1
	Back Panel Sub-Assembly		GG-2081-1
	Burner Support Channel		GG-2066-1
	Angle Tie Brace		GG-2065
	Front Panel Support Bracket		GG-2069
	Section Assembly Kit		GG-1030
2CC	Front Panel Sub-Assembly	90342	GG-2080-2
	Back Panel Sub-Assembly		GG-2081-2
	Burner Support Channel		GG-2066-2
	Angle Tie Brace		GG-2065
	Front Panel Support Bracket		GG-2069
	Section Assembly Kit		GG-1030-1
2DD	Front Panel Sub-Assembly	90343	GG-2080-3
	Back Panel Sub-Assembly		GG-2081-3
	Burner Support Channel		GG-2066-3
	Angle Tie Brace		GG-2065
	Front Panel Support Bracket		GG-2069
	Section Assembly Kit		GG-1030-2
2EE	Front Panel Sub-Assembly	90344	GG-2080-4
	Back Panel Sub-Assembly		GG-2081-4
	Burner Support Channel		GG-2066-4
	Angle Tie Brace		GG-2065
	Front Panel Support Bracket		GG-2069
	Section Assembly Kit		GG-1030-3

2. Open crate number 2. Remove the End Panels and mount a Support Channel Clip toward the rear on each panel as shown in Figure 2.2 using 1/4"-20 x 1/2" (13 mm) long round head machine screws and 1/4" lock washers provided.

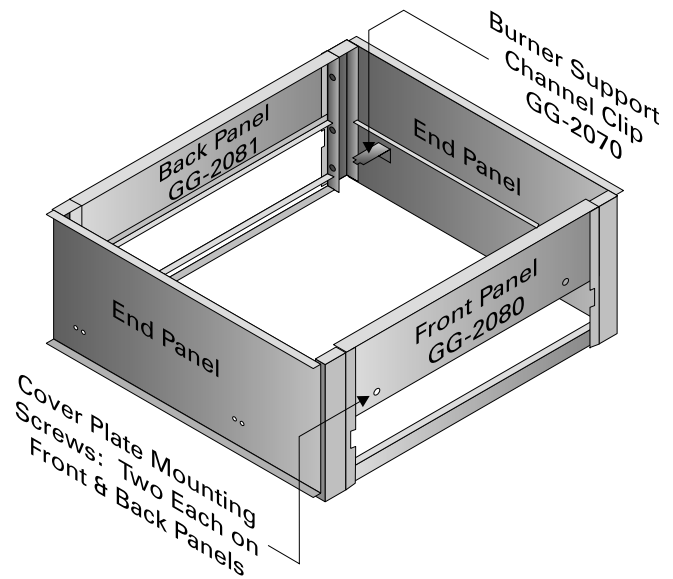

Figure 2.2: Steel Base Assembly

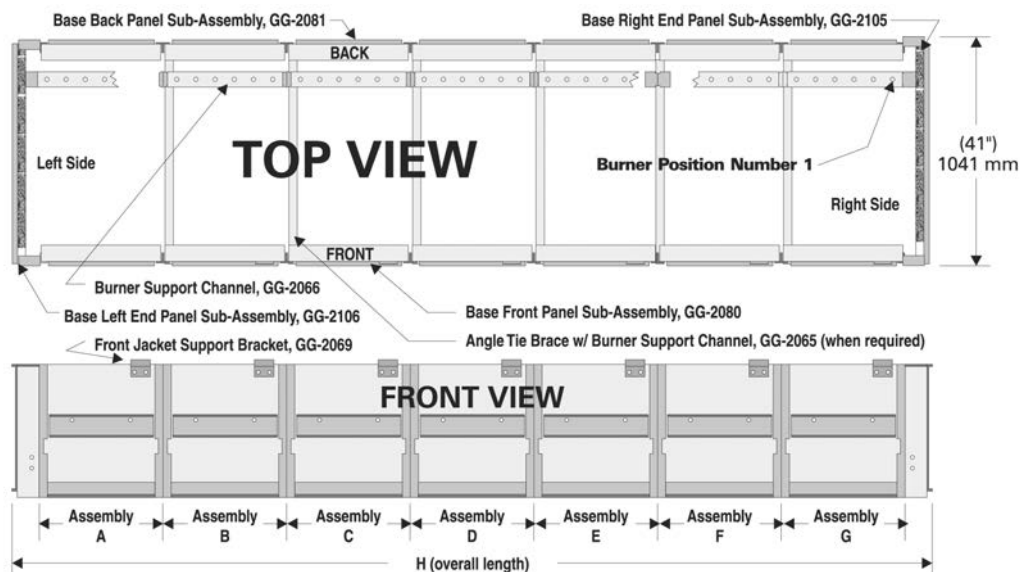

Figure 2.1: Boiler Base Assembly

3. Attach the Front Panel and Back Panel (Figure 2.2) to the Left Hand End Panel using 5/16"-18 x 1" (25 mm) long cap screws and hex head nuts provided.
4. **For 211A™-04 through 211A™-08 Only:**
 - a. Complete the base assembly by attaching the Right End Panel and setting the Burner Support Channel on the clips.

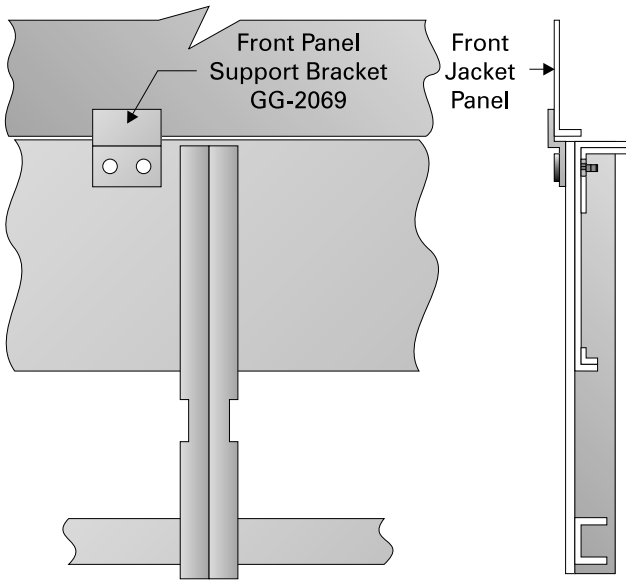

Figure 2.3: Support Bracket Installation

5. **For 211A™-09 through 211A™-46 Only:**
 - a. Attach a Front Panel Support Bracket to each Front Panel as shown in Figure 2.3.
6. Attach an Angle Tie Brace at each panel joint to secure the front and back panels as shown in Figure 2.4 using 5/16"-18 x 1" (25 mm) long cap screws and hex head nuts.
7. Bolt remaining Front and Back Panels together using 5/16"-18 x 1" (25 mm) long cap screws and hex head nuts. See Table 2.1 for panels required. Place the panels in the positions shown in the table and Figure 2.1.
8. Complete the base assembly by attaching the Right Hand End Panel using 5/16"-18 x 1" (25 mm) long cap screws and hex head nuts.
9. Set the Burner Support Channels in place as shown in Figure 2.1.

B. INSTALL THE PILOT BURNERS

1. Check the location of the Burner Support Channels in the Base Assembly. The dimensions should be:
 - a. Height above boiler foundation: 6-3/4" (171 mm)
 - b. Distance from back of Base: 3-3/4" (95 mm)
2. Remove the Gas Manifold and Pilot Line Assembly from Box Number 7.
3. Place Manifold on front of Base. Bolt the hangers using 5/16"-18 x 1" (25 mm) long long cap screws with 5/16" flat washers. See Figure 2.5.
4. Place only the Burners **with pilots mounted** in the locations given in Table 2.2. Install the Burners by

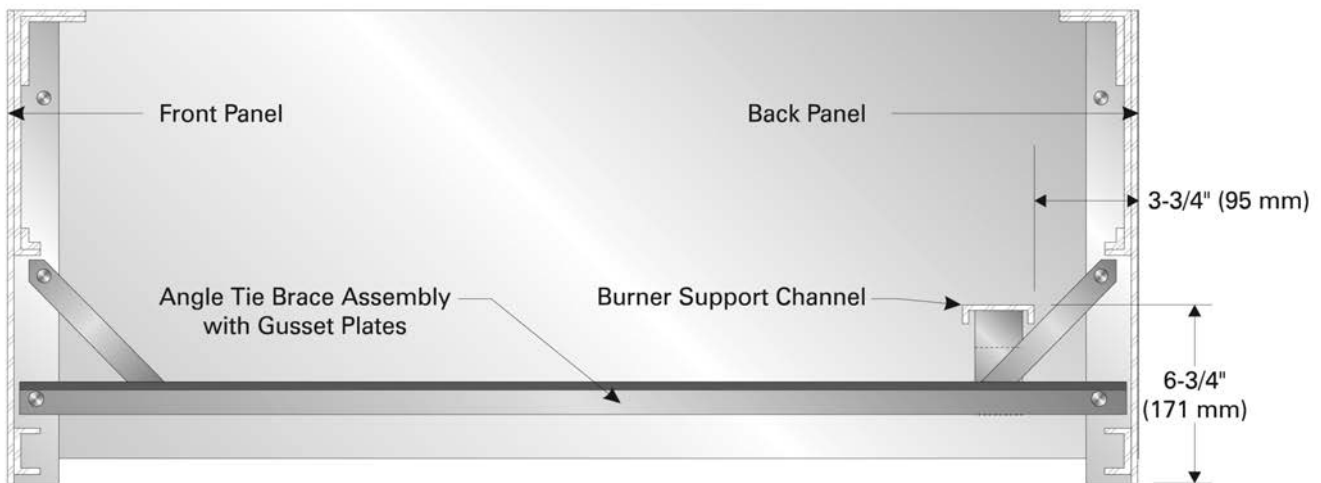
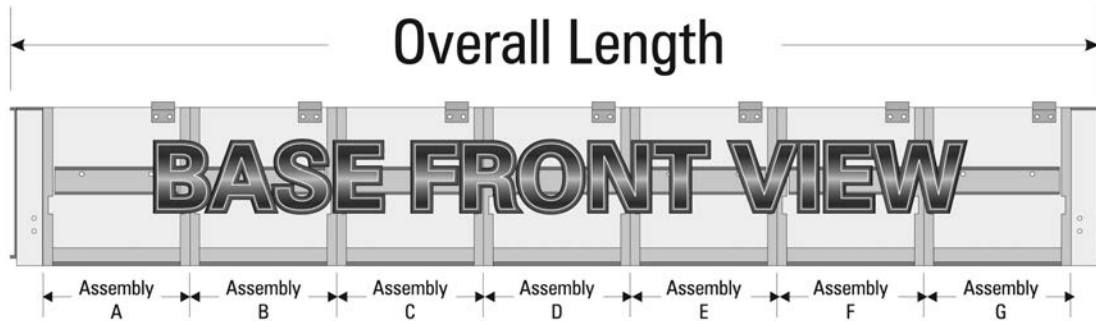

Figure 2.4: Angle Tie Brace Installation

ASSEMBLE THE BASE

Table 2.1: Base Front and Back Panel Crates



Model Number	A	B	C	D	E	F	G	Overall Length	
								feet/inches	mm
211A-04	2AA	—	—	—	—	—	—	24-3/4"	629
211A-05	2BB	—	—	—	—	—	—	30-3/8"	771
211A-06	2CC	—	—	—	—	—	—	36"	914
211A-07	2DD	—	—	—	—	—	—	41-5/8"	1,057
211A-08	2EE	—	—	—	—	—	—	47-1/4"	1,200
211A-09	2BB	2BB	—	—	—	—	—	52-7/8"	1,343
211A-10	2CC	2BB	—	—	—	—	—	58-1/2"	1,486
211A-11	2CC	2CC	—	—	—	—	—	64-1/8"	1,629
211A-12	2DD	2CC	—	—	—	—	—	69-3/4"	1,772
211A-13	2DD	2DD	—	—	—	—	—	75-3/8"	1,915
211A-14	2EE	2DD	—	—	—	—	—	81"	2,057
211A-15	2EE	2EE	—	—	—	—	—	86-5/8"	2,200
211A-16	2CC	2CC	2CC	—	—	—	—	92-1/4"	2,343
211A-17	2DD	2CC	2CC	—	—	—	—	97-7/8"	2,486
211A-18	2EE	2CC	2CC	—	—	—	—	8'-7-1/2"	2,629
211A-19	2DD	2DD	2DD	—	—	—	—	9'-1-1/8"	2,772
211A-20	2EE	2EE	2CC	—	—	—	—	9'-6-3/4"	2,915
211A-21	2EE	2EE	2DD	—	—	—	—	10'-0-3/8"	3,058
211A-22	2EE	2EE	2EE	—	—	—	—	10'-6"	3,200
211A-23	2EE	2CC	2CC	2CC	—	—	—	10'-11-5/8"	3,343
211A-24	2DD	2DD	2DD	2CC	—	—	—	11'-5-1/4"	3,486
211A-25	2EE	2EE	2CC	2CC	—	—	—	11'-10-7/8"	3,629
211A-26	2EE	2EE	2EE	2BB	—	—	—	12'-4-1/2"	3,772
211A-27	2EE	2EE	2EE	2CC	—	—	—	12'-10-1/8"	3,915
211A-28	2EE	2EE	2EE	2DD	—	—	—	13'-3-3/4"	4,058
211A-29	2EE	2EE	2EE	2EE	—	—	—	13'-9-3/8"	4,201
211A-30	2DD	2DD	2DD	2DD	2CC	—	—	14'-3"	4,343
211A-31	2DD	2DD	2DD	2DD	2DD	—	—	14'-8-5/8"	4,486
211A-32	2EE	2DD	2DD	2DD	2DD	—	—	15'-2-1/4"	4,629
211A-33	2EE	2EE	2BB	2EE	2EE	—	—	15'-7-7/8"	4,772
211A-34	2EE	2EE	2EE	2EE	2CC	—	—	16'-1-1/2"	4,915
211A-35	2EE	2EE	2EE	2EE	2DD	—	—	16'-7-1/8"	5,058
211A-36	2EE	2EE	2EE	2EE	2EE	—	—	17'-0-3/4"	5,201
211A-37	2DD	2DD	2DD	2DD	2DD	2DD	—	17'-6-3/8"	5,344
211A-38	2EE	2DD	2DD	2DD	2DD	2DD	—	18'-0"	5,486
211A-39	2DD	2DD	2EE	2EE	2DD	2DD	—	18'-5-5/8"	5,629
211A-40	2BB	2EE	2EE	2EE	2EE	2EE	—	18'-11-1/4"	5,772
211A-41	2EE	2EE	2DD	2DD	2EE	2EE	—	19'-4-7/8"	5,915
211A-42	2DD	2EE	2EE	2EE	2EE	2EE	—	19'-10-1/2"	6,058
211A-43	2EE	2EE	2EE	2EE	2EE	2EE	—	20'-4-1/8"	6,201
211A-44	2EE	2BB	2EE	2EE	2EE	2BB	2EE	20'-9-3/4"	6,344
211A-45	2CC	2BB	2EE	2EE	2EE	2EE	2EE	21'-3-3/8"	6,487
211A-46	2CC	2CC	2EE	2EE	2EE	2EE	2EE	21'-9"	6,629

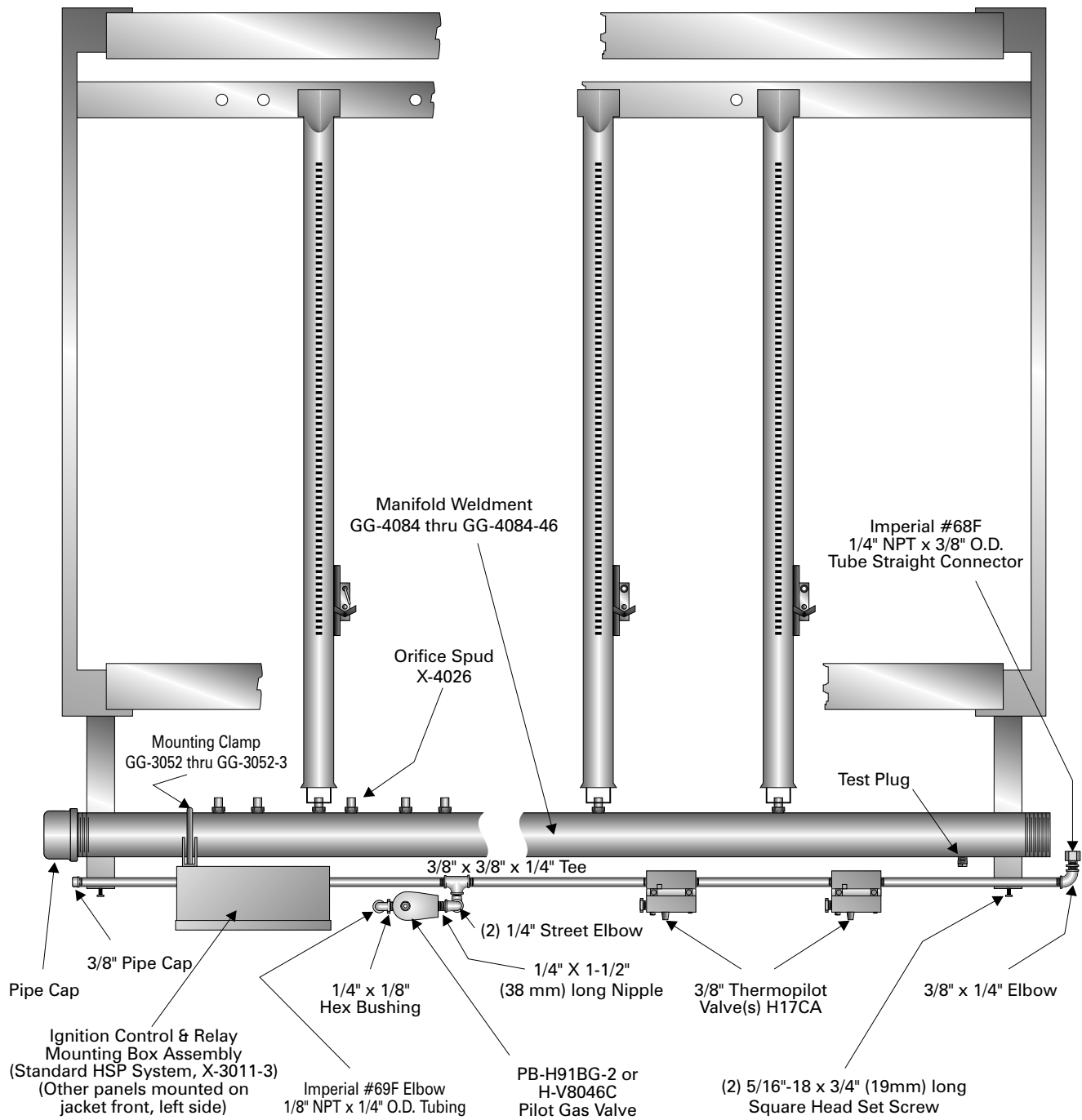

Figure 2.5: Typical Gas Manifold and Pilot Line Assembly

- slipping the opening on the front of the burner over the orifice adapter and slipping the pin on the end of the burner into the hole in the Burner Support Channel directly opposite the orifice.
- Cut and fit the 1/4" aluminum tubing provided from the pilot gas shut-off device(s) to the pilot burners.
 - Do not install the remaining burners until the Boiler Sections are installed.

ASSEMBLE THE BASE

Table 2.2: Burner Cartons and Pilot Burner Locations (See Figure 2.1)

Boiler Model Number	Burner Cartons						Number of Pilots	Total Number of Burners	HSP Ignition System		E1E Ignition System	
									Pilot Burner Locations (Positions Numbered Right to Left)		Pilot Burner Locations (Positions Numbered Right to Left)	
	15A	15B	15C	15D	15E	15F			Electronic Pilots (Spark Ignited)	Standing Pilots (Thermocouple)	Electronic Pilots (Spark Ignited)	Standing Pilots (Thermocouple)
211A-04	1						1	6	5	—	5	—
211A-05		1					1	8	5	—	5	—
211A-06			1				1	10	5	—	5	—
211A-07				1			1	12	5	—	5	—
211A-08					1		1	14	5	—	5	—
211A-09						1	1	16	5	—	5	—
211A-10	1			1*			1	18	5	—	7	—
211A-11	1				1		2	20	15	5	15	5
211A-12	1					1	2	22	15	5	15	5
211A-13		1				1	2	24	17	5	17	5
211A-14			1			1	2	26	17	5	17	5
211A-15				1		1	2	28	19	5	19	5
211A-16	1	1				1	3	30	25	5, 15	25	5, 15
211A-17	1		1			1	3	32	25	5, 15	25	5, 15
211A-18	1			1		1	3	34	25	5, 15	25	5, 15
211A-19	1				1	1	3	36	29	5, 17	29	5, 17
211A-20	1					2	3	38	35	5, 21	35	5, 21
211A-21		1				2	3	40	37	5, 23	37	5, 23
211A-22			1			2	3	42	19	5, 39	39	5, 19
211A-23				1		2	3	44	19	5, 41	41	5, 19
211A-24					1	2	3	46	21	5, 39	39	5, 21
211A-25						3	3	48	25	5, 45	45	5, 25
211A-26	1			1		2	4	50	19	5, 33, 47	47	5, 19, 33
211A-27			1		3		4	52	21	5, 35, 49	49	5, 21, 35
211A-28	1					3	4	54	23	5, 37, 51	51	5, 17, 37
211A-29		1				3	4	56	27	5, 39, 53	53	5, 19, 39
211A-30			1			3	4	58	29	5, 39, 51	51	5, 21, 33
211A-31				1		3	4	60	31	5, 41, 53	53	5, 23, 41
211A-32					1	3	4	62	33	5, 41, 59	59	5, 23, 41
211A-33						4	4	64	35	5, 41, 61	61	5, 25, 41
211A-34			1		4		5	66	35	5, 21, 49, 63	63	5, 21, 49
211A-35				1	4		5	68	37	5, 17, 51, 65	65	5, 17, 51
211A-36					5		5	70	37	5, 19, 53, 67	67	5, 19, 53
211A-37		1				4	5	72	37	5, 23, 47, 65	65	5, 23, 47

* 211A-10 Gas Burner Carton includes two burners with pilot bracket but only one pilot bracket is used.

3. PLACE THE BOILER SECTIONS

A. PREPARATION

1. Check the level of the Boiler Base using a spirit level. Make sure the base is level and that the base panels are aligned within plus or minus 1/16" (2 mm).
2. Check the area around the Flow Ports (Figure 3.1). Use solvent and a clean cloth to thoroughly clean the flat surfaces and recesses. All foreign matter must be removed to assure a proper seal when the sections are drawn together.

⚠ CAUTION

Gaskets will be damaged by petroleum or its derivatives. Completely remove all solvent residue before placing gaskets.

Do not use petroleum based compounds in the boiler.

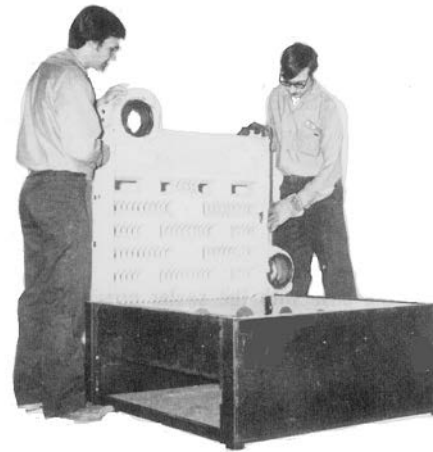

Figure 3.2: Placing the First Section on Base

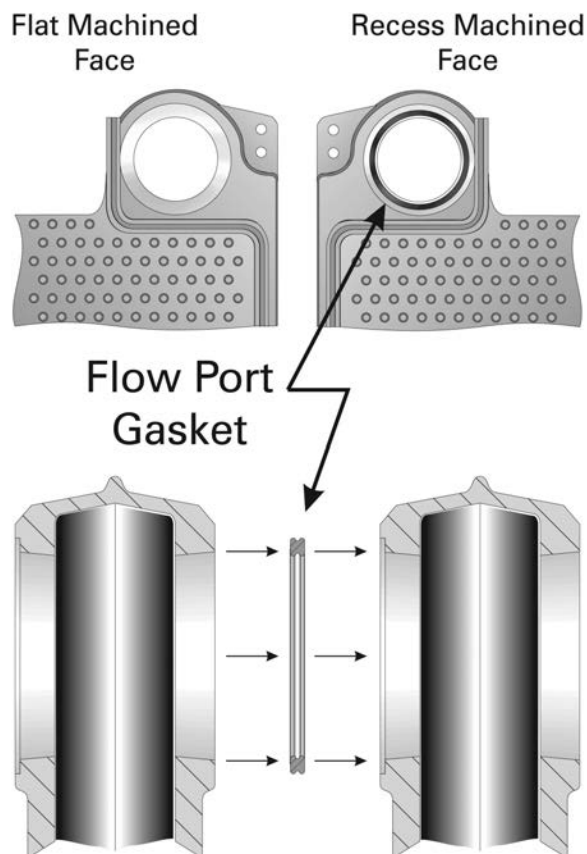

Figure 3.1: Flow Port Machining & Gasket

B. PLACING THE SECTIONS

1. Begin by placing the Left Hand End Section on the left end of the base. The upper flow port goes toward the front of the boiler as shown in Figure 3.2.

2. Slide the section to the back of the base until the cast lug on the bottom of the section under the lower flow port is against the base back panel. Keep the section upright by a supporting prop or other means.

⚠ WARNING

The sections are heavy and must be supported securely.

3. Align the parting line of the section with the seam between the Base End panel and the Base Front Panel as shown in Figure 3.3.
4. Apply Hi-Temp rope seal by spreading a thin coat of spray adhesive in the grooves on each end of the section. Place the rope in the grooves. Do not stretch the rope. The longer rope goes in the front groove. NOTE: The ends of each rope must extend 1/2" (13 mm) beyond the top and bottom.
5. Place the Flow Port Gaskets in the recesses provided (see Figure 3.1). **Do not use adhesive.**
6. The following steps must be followed to insure that no damage is done to the tie rod lugs. A 0-100 ft.-lbs. (0-136 N·m) torque wrench is required.
 - a. Place an Intermediate Section on the base and slide it carefully against the Left Hand End Section.
 - b. Align the flow ports from front to back, as close as possible.
 - c. Insert a tie rod into each of the lugs on each section and apply a nut and washer to each end of the tie rod.
 - d. Before tightening, check the vertical alignment of the sections using a spirit level (see Figure 3.4). Make sure they are square with the Base.

PLACE THE BOILER SECTIONS

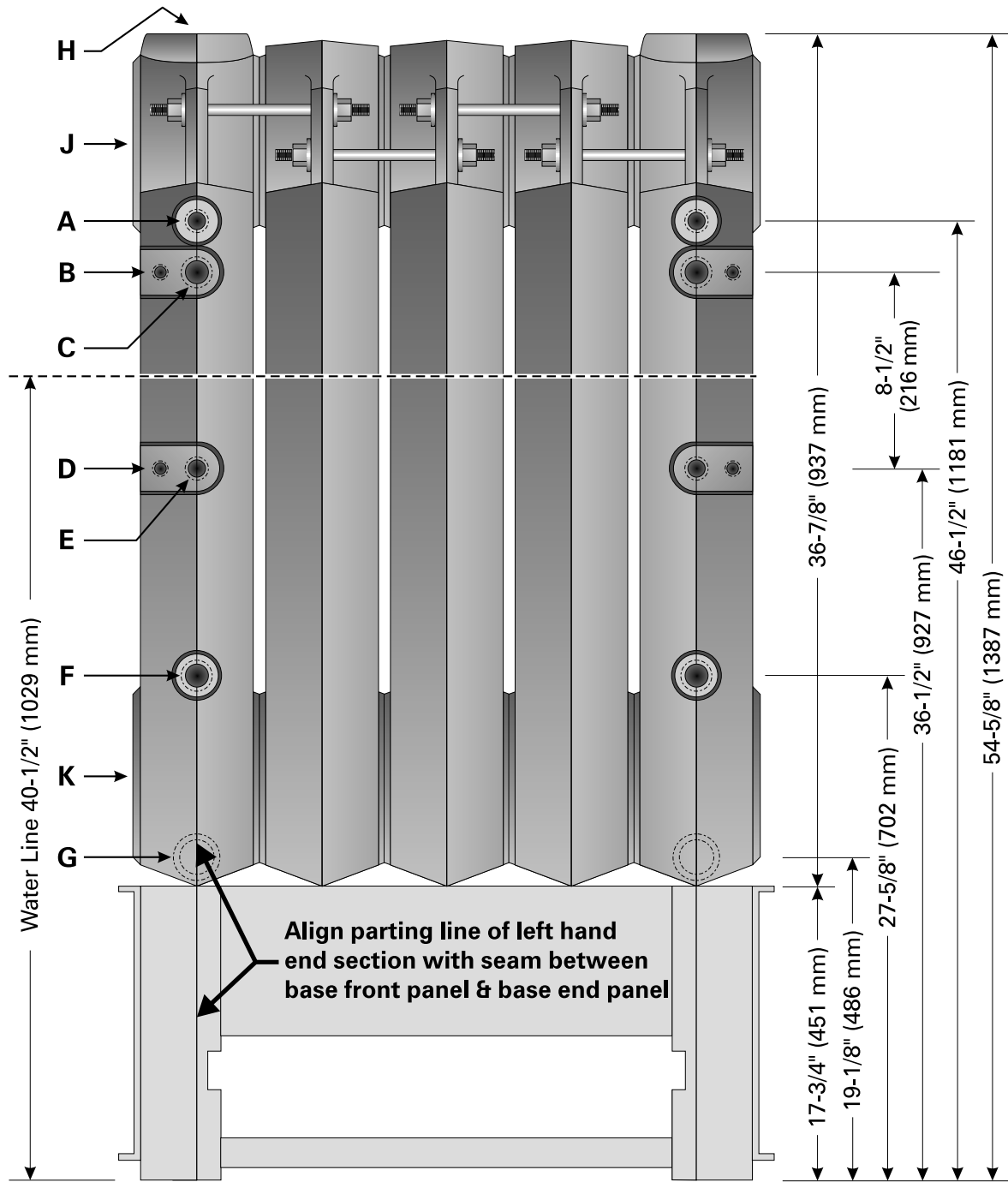

TAPPINGS, EACH END SECTION

- | | |
|--------------------------------|---|
| A 3/4" NPT Tapping | G 1-1/2" NPT Tapping, Back, Blowdown |
| B 1/2" NPT Tapping, Upper | H 3" NPT Tapping, Pop Safety Valve(s) and Upper Equalizer for Special Float Controls (157, etc) |
| C 1" NPT Tapping, Upper | J 6" NPT Tapping, Steam Riser |
| D 1/2" NPT Tapping, Lower | K 6" NPT Tapping, Return |
| E 3/4" NPT Tapping, Probe LWCO | |
| F 1" NPT Tapping, Lower | |

Figure 3.3: Assembling Sections on Base

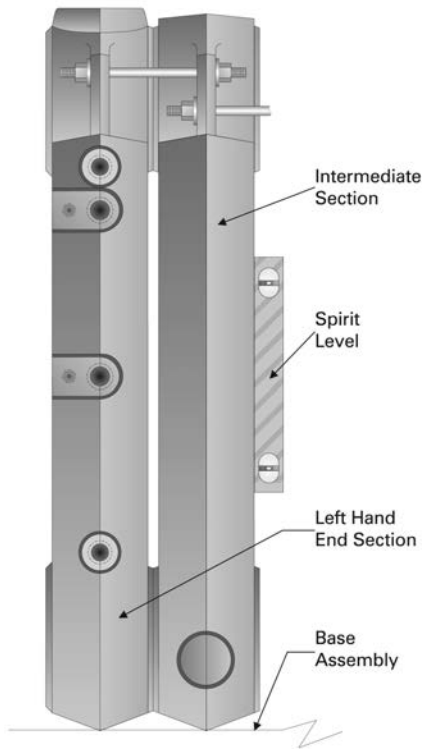

Figure 3.4: Align Sections Vertically

- e. Draw sections together evenly, alternating between top lug and bottom lug in increments of 20 ft.-lbs. (27 N·m). Continue until both top and bottom lugs are tightened to 60 ft.-lbs. (81 N·m). DO NOT EXCEED 60 FT.-LBS (81 N·m).
 - f. Check the level while tightening to make sure alignment stays true. Also make sure sections remain square with the Base from front to back as the tie rods are tightened and as additional sections are installed.
 - g. If the sections tend to run out of plumb, this will usually be at the bottom front. Loosen the upper nuts slightly and tighten the lower ones to adjust.
7. Assemble the remaining sections in the same way for a finished assembly as shown in Figure 3.3.
 8. Some of the Intermediate Sections have tappings for installing additional steam risers from the boiler. These Tapped Intermediate Sections must be installed as shown in Figure 3.5A. The placement order is left to right (Figure 3.5).

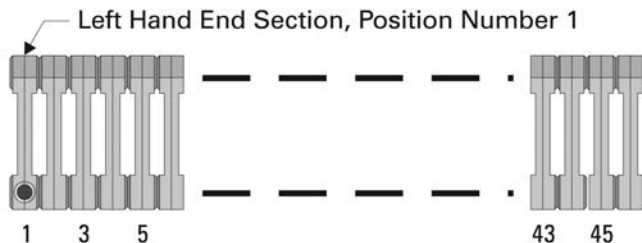

Figure 3.5: Section Positioning Numbering

Boiler Model Number	Place Tapped Intermediate Sections as Positions (numbered Left to Right)
211A-18	10
211A-19	10
211A-20	11
211A-21	11
211A-22	8, 16
211A-23	8, 16
211A-24	9, 17
211A-25	7, 13, 19
211A-26	7, 13, 20
211A-27	7, 12, 17, 22
211A-28	5, 11, 17, 23
211A-29	5, 10, 15, 20, 25
211A-30	6, 11, 16, 21, 26
211A-31	6, 10, 14, 18, 22, 26
211A-32	6, 11, 15, 19, 23, 27
211A-33	5, 9, 13, 17, 21, 25, 29
211A-34	5, 9, 13, 17, 22, 26, 30
211A-35	5, 9, 13, 18, 23, 27, 31
211A-36	5, 9, 13, 17, 21, 25, 29, 33
211A-37	5, 9, 13, 17, 21, 25, 29, 33
211A-38	4, 8, 12, 17, 22, 27, 31, 35
211A-39	4, 8, 12, 16, 20, 24, 28, 32, 36
211A-40	4, 8, 12, 16, 21, 25, 29, 33, 37
211A-41	4, 8, 12, 16, 19, 23, 26, 30, 34, 38
211A-42	4, 8, 12, 16, 20, 23, 27, 31, 35, 39
211A-43	4, 7, 11, 14, 18, 22, 26, 30, 33, 37, 40
211A-44	4, 8, 12, 16, 19, 23, 26, 29, 33, 37, 41
211A-45	4, 7, 11, 14, 18, 21, 25, 28, 32, 35, 39, 42
211A-46	4, 7, 11, 14, 18, 22, 25, 29, 33, 36, 40, 43

Figure 3.5A: Section Position Numbering

C. HYDROSTATIC TEST THE BOILER

1. The supply and return piping can be permanently erected before applying the Boiler Jacket if the pipe nipples applied to the boiler tappings are long enough to clear the jacket.
2. Install a drain cock in the tapping provided at the bottom rear of each end section.
3. Provide a water supply line to the boiler.
4. Plug all open tappings in the boiler.
5. Provide a means to vent air as the boiler fills.
6. Fill the boiler with water, venting air as water level rises.
7. Pressurize boiler to 45 psig (310 kPa). **Do not exceed this pressure.**
 - a. Maintain pressure while checking all joints and fittings for leaks.
 - b. After inspection is complete, drain the boiler and remove plugs from tappings that are to be used.

4. INSTALL THE FLUE COLLECTOR

1. Collect the Flue Collector cartons. The Flue Collector sections are labeled on the part and on the carton. See Table 4.1 for the items needed.
2. Install Hi Temp Rope for **each** collector section as shown in Figure 4.1. The rope provides the seal to prevent flue gases from leaking from the collector. Make certain that the rope is well under the bottom edges of each flue collector section in order to obtain a tight seal.
3. Place the Flue Collector sections in the positions given in Table 4.1. These positions are **numbered from left to right when facing the front of the boiler.**
4. Fasten an angle bracket, part number GG-5005, to the top of each Collector section with two #10 x 1/2" (13 mm) long sheet metal screws. See Figure 4.2.
5. Insert a Long Hook Bolt, part number GG-5003, through the angle bracket. Slip the hook end over the tie rod. Apply a 1/4"-20 hex nut on the end of the rod and snug against the bracket. See Figure 4.2. Do not tighten yet.
6. Insert a Short Hook Bolt, part number GG-5004, through the flange in the rear of the flue collector. Catch the hook around the spacer pads at the top of the boiler sections. Apply a 1/4"-20 hex nut on the Bolt and snug against the flange. See Figure 4.2. Do not tighten yet.

7. Draw the Flue Collector sections tight against the sealing rope by tightening the nuts on the Hook Bolts. Draw the nuts evenly, alternating tightening.

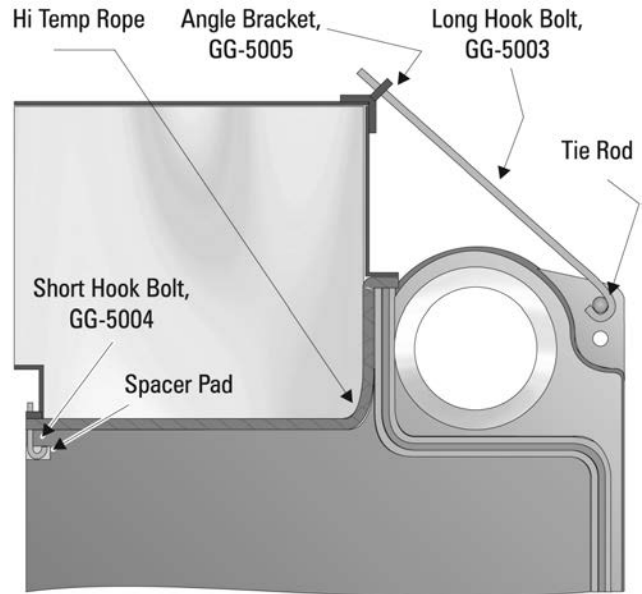

Figure 4.2: Installing Flue Collector Sections

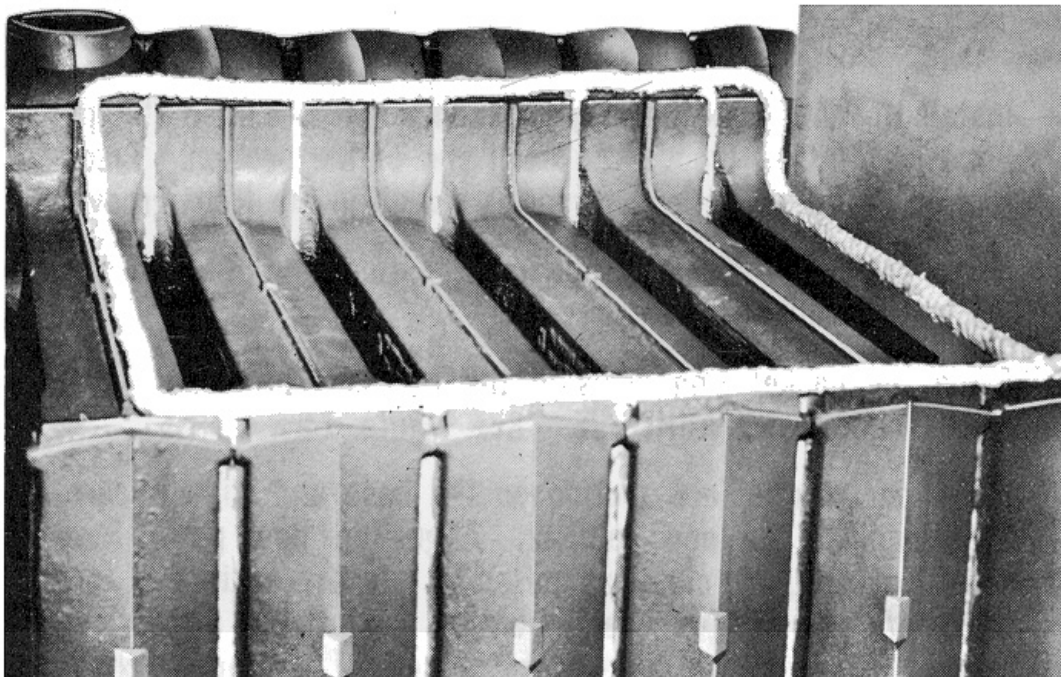

Figure 4.1: Applying Flue Collector Hi Temp Rope Gasket

Table 4.1: Flue Collector Section Location (From Left to Right Facing Front of Boiler) – Crates
Crates 14 = Part number GG-5000 **Crate 14A = Part number GG-5000-1**
Crate 14B = Part number GG-5000-2

Boiler Model Number	Position 1	Position 2	Position 3	Position 4	Position 5	Position 6	Position 7	Position 8	Position 9
211A-04	14	—	—	—	—	—	—	—	—
211A-05	14A	—	—	—	—	—	—	—	—
211A-06	14B	—	—	—	—	—	—	—	—
211A-07	14	14	—	—	—	—	—	—	—
211A-08	14A	14	—	—	—	—	—	—	—
211A-09	14A	14A	—	—	—	—	—	—	—
211A-10	14B	14A	—	—	—	—	—	—	—
211A-11	14B	14B	—	—	—	—	—	—	—
211A-12	14A	14A	14	—	—	—	—	—	—
211A-13	14A	14A	14A	—	—	—	—	—	—
211A-14	14B	14A	14A	—	—	—	—	—	—
211A-15	14B	14A	14B	—	—	—	—	—	—
211A-16	14B	14B	14B	—	—	—	—	—	—
211A-17	14A	14A	14A	14A	—	—	—	—	—
211A-18	14B	14A	14A	14A	—	—	—	—	—
211A-19	14A	14B	14B	14A	—	—	—	—	—
211A-20	14B	14B	14B	14A	—	—	—	—	—
211A-21	14B	14B	14B	14B	—	—	—	—	—
211A-22	14B	14A	14A	14A	14A	—	—	—	—
211A-23	14B	14B	14A	14A	14A	—	—	—	—
211A-24	14B	14B	14B	14A	14A	—	—	—	—
211A-25	14B	14B	14B	14B	14A	—	—	—	—
211A-26	14B	14B	14B	14B	14B	—	—	—	—
211A-27	14B	14B	14A	14A	14A	14A	—	—	—
211A-28	14B	14B	14B	14A	14A	14A	—	—	—
211A-29	14B	14B	14B	14B	14A	14A	—	—	—
211A-30	14B	14B	14B	14B	14B	14A	—	—	—
211A-31	14B	14B	14B	14B	14B	14B	—	—	—
211A-32	14B	14B	14B	14A	14A	14A	14A	—	—
211A-33	14B	14B	14B	14B	14A	14A	14A	—	—
211A-34	14B	14B	14B	14B	14B	14A	14A	—	—
211A-35	14B	14B	14B	14B	14B	14B	14A	—	—
211A-36	14B	14B	14B	14B	14B	14B	14B	—	—
211A-37	14B	14B	14B	14B	14A	14A	14A	14A	—
211A-38	14A	14A	14A	14B	14B	14B	14B	14B	—
211A-39	14A	14A	14B	14B	14B	14B	14B	14B	—
211A-40	14A	14B	14B	14B	14B	14B	14B	14B	—
211A-41	14B	14B	14B	14B	14B	14B	14B	14B	—
211A-42	14A	14A	14A	14A	14B	14B	14B	14B	14B
211A-43	14A	14A	14A	14B	14B	14B	14B	14B	14B
211A-44	14A	14A	14B	14B	14B	14B	14B	14B	14B
211A-45	14A	14B	14B	14B	14B	14B	14B	14B	14B
211A-46	14B	14B	14B	14B	14B	14B	14B	14B	14B

5. PIPE THE BOILER

A. PREPARATION

1. The boiler must be pressure tested as outlined in **Chapter 3, "Place the Boiler Sections,"** of this manual.
2. The Supply and Return piping can be installed before the jacket is applied. Use nipples long enough to be sure they will extend through the jacket.

B. SUPPLY PIPING

1. Install End Riser connections sized per Table 5.1. The 3" tapings in the tops of the end sections are not used for steam boilers.
 - a. Install a reducing tee on one end riser. Install a 2" valve, nipple and cap for skimming the boiler in the tee as shown in the piping drawings.
2. **Models 211A™-08 and larger** require risers in both end sections.
3. **Models 211A™-18 and larger** require additional 3" risers off of the tapped intermediate sections. See Table 5.1 for the number required.
4. Pipe the header at least 24 inches (610 mm) above the normal boiler water line. This is required to prevent water from carrying over into the header and then to the system.
5. Figure 5.2 shows the Supply and Return piping for Parallel Flow Gravity systems and all Pumped Return Systems.

6. Counterflow Gravity systems require the boiler steam line to enter the top of the steam main. See Figure 5.3 for this special case.
7. The piping in these drawings is shown off the right hand side of the boiler. The boiler may also be piped toward the left side as shown in Figure 5.4, typical.
8. **Do not reduce the size or number of risers shown.** These are required for reliable operation of the boiler. If the risers are undersized or incorrectly placed, a sloped water line can occur in the boiler, causing possible overheating of some sections.
9. **Pipe the Header with an offset** as shown in the drawings. This offset prevents the expansion and contraction of the Header from damaging the boiler sections. Use threaded fittings for swing joints.
10. **Always locate the Steam Supply take-off between the Equalizer and the last Boiler Riser.** (See PB Heat's "Steam Installation Survey" for discussion). Locating the Steam Supply between the risers will cause water carryover to the system.
11. Do not use a bull head tee to provide steam supply and equalizer connections. This will cause water level bounce and carryover.

C. RETURN PIPING

1. The use of a Hartford loop in all installations is recommended. The loop provides additional reliability for the system. A check valve must still be installed on the pump discharge of all pumped return systems.

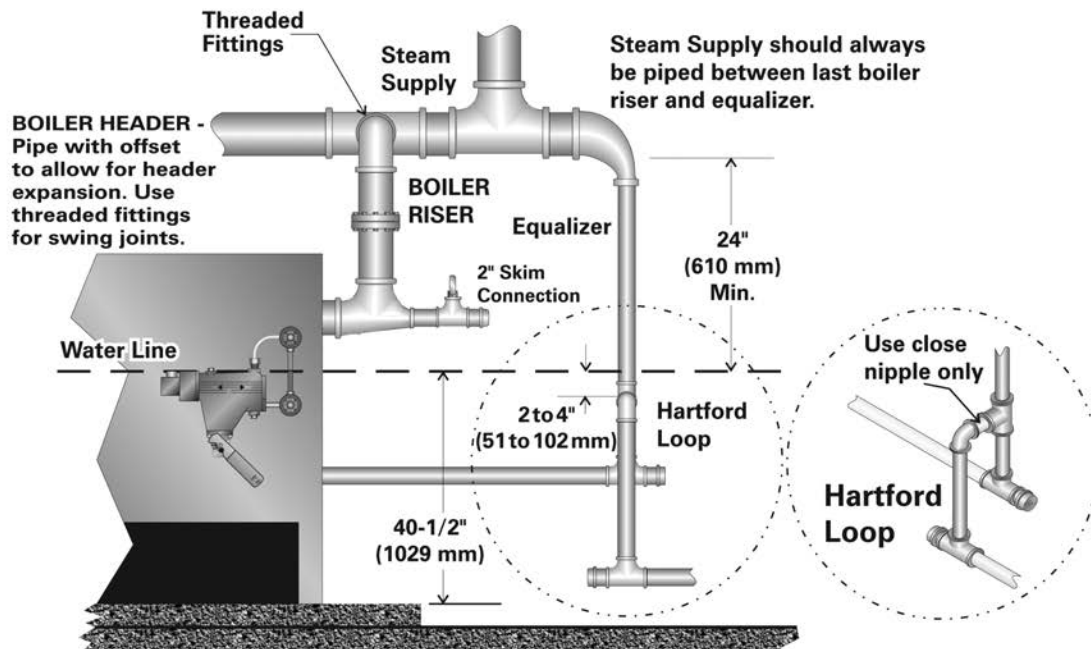

Figure 5.1: Supply and Return Positions, Skim Piping, Hartford Loop

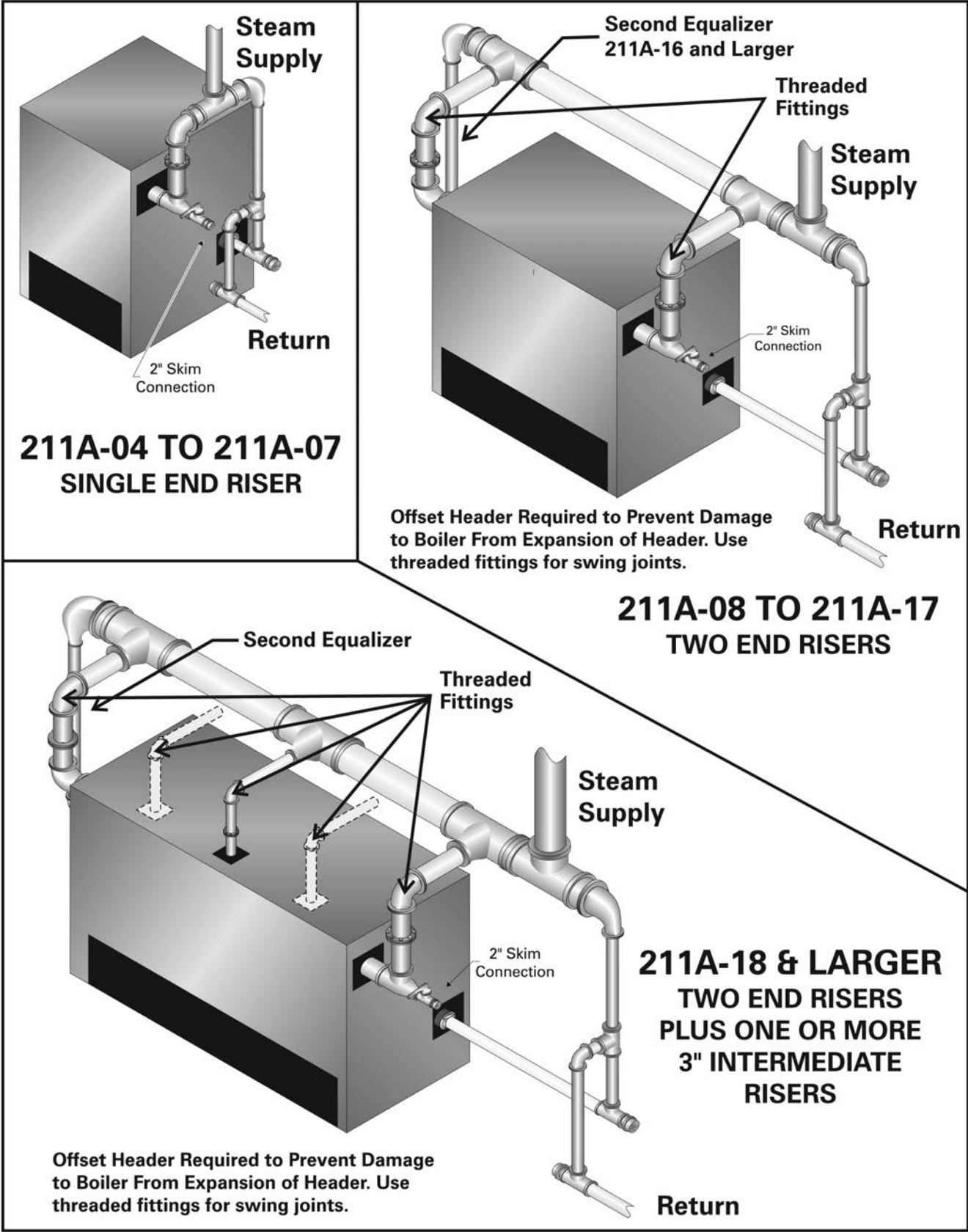

Figure 5.2: Supply and Return Piping – Pumped Return and Parallel Flow Gravity Systems

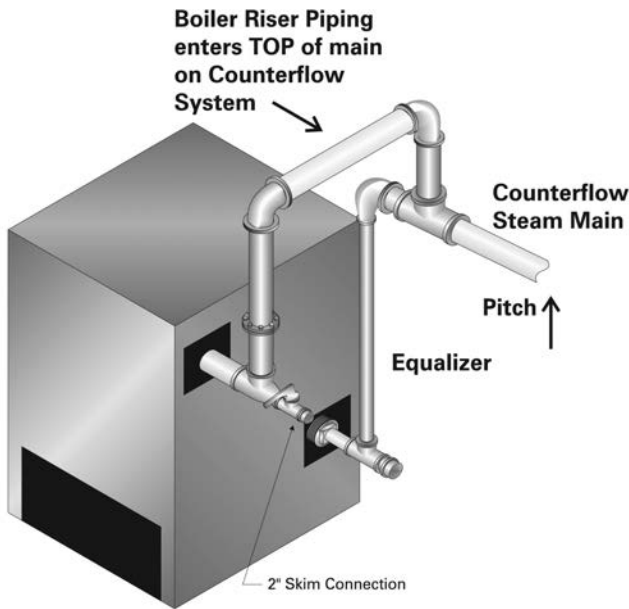

Figure 5.3: Supply and Return Piping – Counterflow Gravity Systems

2. On pumped return systems, install a boiler cock after the pump to allow throttling of the pump discharge. The pressure after the boiler cock should be no more than 5 psig (35 kPa) above the boiler operating pressure. Pumping the water into the boiler too fast will cause collapse of the water level and level control problems.
3. Size the equalizer per Table 5.1.
4. Pipe the Hartford loop tee so the inside top of the close nipple is 2 to 4 inches (51 to 102 mm) below the boiler water line.
5. If the pump discharge is looped overhead, above the boiler water line, install spring-loaded check valves at both the pump discharge and the connection to the boiler return.

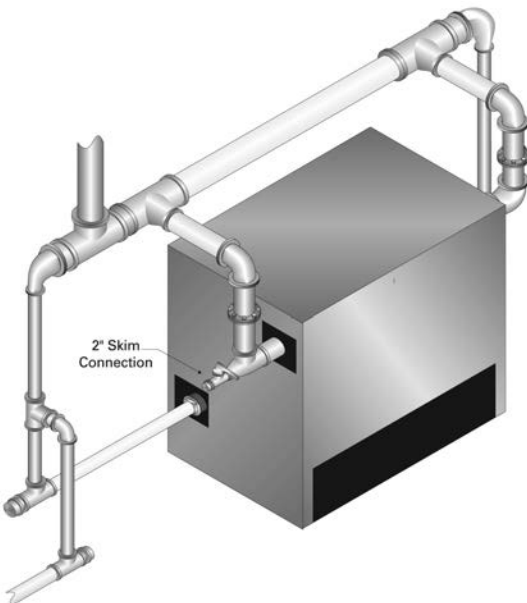

Figure 5.4: Left Hand Piping Arrangement – Typical

D. MULTIPLE BOILER INSTALLATIONS

1. Figure 5.5 shows typical piping for multiple boiler Gravity Return systems. Figure 5.6 shows typical piping for multiple boiler Pumped Return systems.
2. Provide separate feed lines for multiple boiler pumped return systems. Use either separate feed pumps or solenoid valves to isolate feeding of the boilers. This is needed to provide reliable level control and avoid nuisance performance problems.
3. Condensate return units are not effective for multiple boiler installations since they do not respond to the needs of the boilers. Always use Boiler feed units.
 - a. Install a Float and Thermostatic trap at the boiler water level on each of the multiple boilers on a pumped return system. This prevents flooding of idle boilers due to condensation of steam.

Table 5.1: Header, Risers & Equalizer Sizing

Boiler Model	Header Size	End Risers		Interm. Risers		Equalizers	
		No.	Size	No.	Size	No.	Size
211A-04	4"	1	4"	-	-	1	2-1/2"
211A-05	5"	1	5"	-	-	1	2-1/2"
211A-06	5"	1	5"	-	-	1	2-1/2"
211A-07	5"	1	5"	-	-	1	2-1/2"
211A-08	6"	2	5"	-	-	1	2-1/2"
211A-09	6"	2	5"	-	-	1	2-1/2"
211A-10	6"	2	5"	-	-	1	3"
211A-11	6"	2	5"	-	-	1	3"
211A-12	8"	2	5"	-	-	1	3"
211A-13	8"	2	5"	-	-	1	3"
211A-14	8"	2	5"	-	-	1	3"
211A-15	8"	2	6"	-	-	1	3"
211A-16	8"	2	6"	-	-	2	4"
211A-17	8"	2	6"	-	-	2	4"
211A-18	8"	2	6"	1	3"	2	4"
211A-19	8"	2	6"	1	3"	2	4"
211A-20	8"	2	6"	1	3"	2	4"
211A-21	8"	2	6"	1	3"	2	4"
211A-22	8"	2	6"	2	3"	2	4"
211A-23	8"	2	6"	2	3"	2	4"
211A-24	10"	2	6"	2	3"	2	4"
211A-25	10"	2	6"	3	3"	2	4"
211A-26	10"	2	6"	3	3"	2	4"
211A-27	10"	2	6"	4	3"	2	4"
211A-28	10"	2	6"	4	3"	2	5"
211A-29	10"	2	6"	5	3"	2	5"
211A-30	10"	2	6"	5	3"	2	5"
211A-31	10"	2	6"	6	3"	2	5"
211A-32	10"	2	6"	6	3"	2	5"
211A-33	10"	2	6"	7	3"	2	5"
211A-34	10"	2	6"	7	3"	2	5"
211A-35	10"	2	6"	7	3"	2	5"
211A-36	10"	2	6"	8	3"	2	5"
211A-37	10"	2	6"	8	3"	2	5"
211A-38	10"	2	6"	8	3"	2	5"
211A-39	10"	2	6"	9	3"	2	5"
211A-40	10"	2	6"	9	3"	2	5"
211A-41	10"	2	6"	10	3"	2	5"
211A-42	10"	2	6"	10	3"	2	5"
211A-43	10"	2	6"	11	3"	2	5"
211A-44	12"	2	6"	11	3"	2	5"
211A-45	12"	2	6"	12	3"	2	5"
211A-46	12"	2	6"	12	3"	2	5"

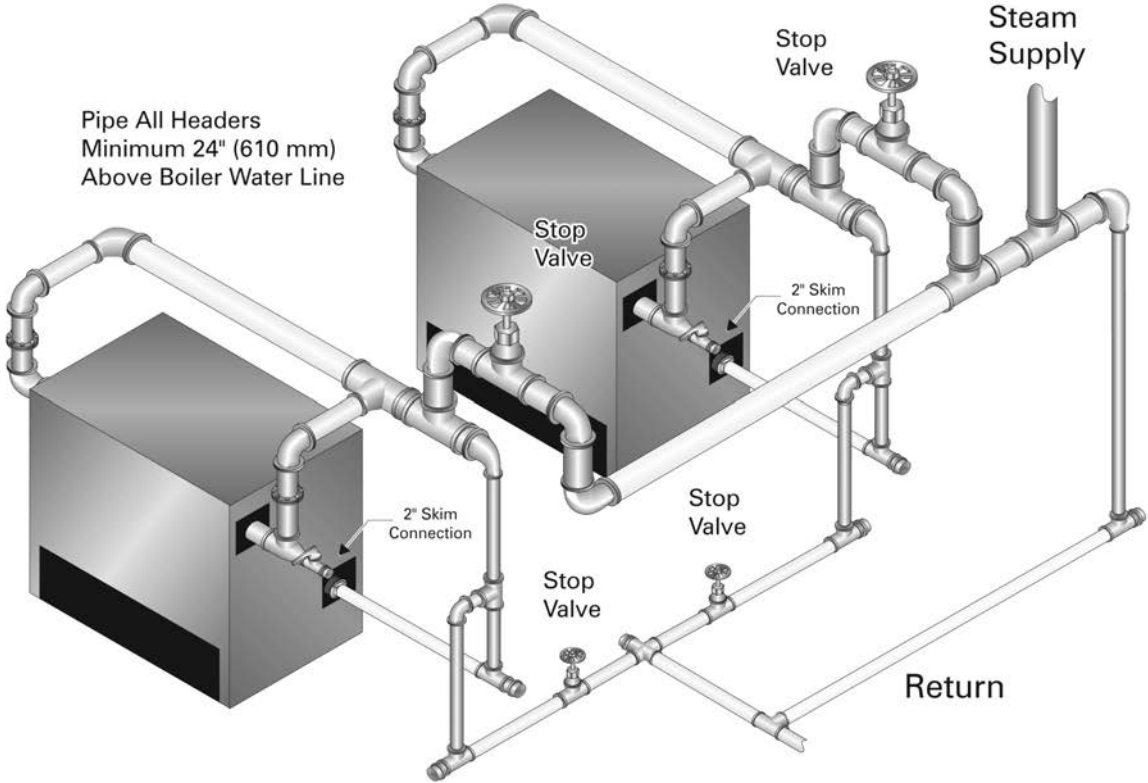

Figure 5.5: Piping Multiple Boilers, Typical, Gravity Return Systems

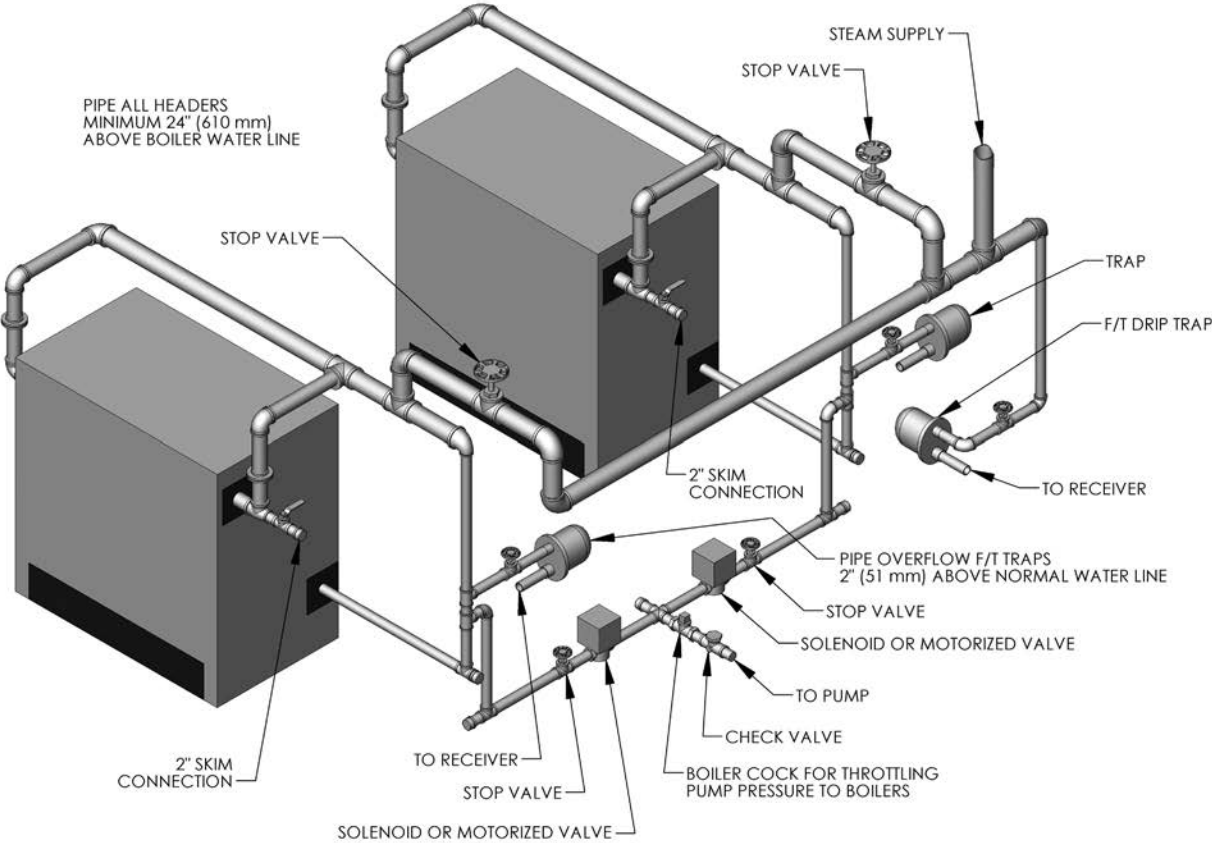

Figure 5.6: Piping Multiple Boilers, Typical, Pumped Return Systems

6. INSTALL THE JACKET & DRAFT HOOD

A. PREPARE THE PARTS

1. Collect the Jacket cartons and Draft Hood cartons (numbers 12 and 13).
2. See Figure 6.2 for the Jacket Assembly. Use these drawings for part identification and location.
3. See Figure 6.3 for the quantity of each carton required and placement of the jacket sections on the boiler.
4. See Table 6.1 for the contents of each Jacket Carton and Draft Hood carton.
5. See Table 6.2 for the Draft Hood cartons required.

B. APPLY CLEANOUT COVER PLATES

1. Remove Cleanout Cover Plates from carton 12.
2. Install one cover plate on each End Section. Use four 5/16"-18 x 2" (51 mm) long studs, 5/16-18" hex nuts and 5/16" flat washers.
3. Seal around the cleanout plates using the furnace cement provided and apply between base and bottom of sections.

C. APPLY JACKET END ASSEMBLIES

1. Remove necessary knockouts from the Jacket End Panel pieces in carton 12.
2. Attach a Corner Panel Support Bracket (GG-6029) to each Corner Panel using two #10 x 1/2" (13 mm) long sheet metal screws.
3. Attach the four Corner Panels to the Base Ends using 1/4"-20 x 1/2" (13 mm) long machine screws and 1/4" flat washers. The locations are:
 - Right Front – GG-6015
 - Left Front – GG-6016
 - Right Rear – GG-6017
 - Left Rear – GG-6018
4. Attach an End Panel Cover Plate (GG-6030) to the opening on the Upper Left End Panel if the 6 inch tapping on that end is not used.
5. Attach Upper Left End Panel (GG-6032) to the left end corner panels with five #10 x 1/2" (13 mm) long sheet metal screws.
6. Place Top Left End Panel (GG-6020) over the Corner Panels and Upper Panel with flange pointing downward. Use four #10 x 1/2" (13 mm) long sheet metal screws.
7. Repeat for the Right End.

D. 211A™-04 THROUGH 211A™-08 ONLY

1. Apply Front and Rear Panels as follows.
2. Open Jacket Intermediate Section carton, 12A, B, C, D or E, per Table 6.1. Remove necessary knockouts from panels.
3. Insert Front Panel (GG-6023) flange (on right side of panel) under the edge of the Right Front Corner Panel. Place the left edge of the Front Panel over the offset flange of the Left Front Corner Panel. Line up the screw holes and secure with ten #10 x 1/2" (13 mm) long sheet metal screws.
4. Insert the offset flange of the Upper Rear Panel under the edge of the Left Rear Corner Panel. Place the left edge of the panel over the Right Rear Corner Panel. Line up the holes and secure with ten #10 x 1/2" (13 mm) long sheet metal screws.
5. Apply the Lower Rear Panel using the same procedure and secure with two #10 x 1/2" (13 mm) long sheet metal screws.
6. Install Rear Panel Support Leg (GG-6028) inside the Left Rear Corner Panel. The flanges extend toward the boiler. Line up the holes and secure with three #10 x 1/2" (13 mm) long sheet metal screws.
7. Attach the Lower Rear Panel Guide (GG-6031) to the Rear Base Panel as shown in Figure 6.2.
8. Install the Draft Hood. Work from the left side (facing the front) of the boiler to the right. Apply the Draft Hood Sections in the sequence given in Table 6.2. Attach the Hood sections to the Flue Collector with two #10 x 1/2" (13 mm) long sheet metal screws per collector section.
9. Insert the offset flange of the Jacket Top Panel under the Top Left End Panel. Place the right flange on the Top Right End Panel. The front edge flange goes over the Jacket Front Panel. Line up the holes and secure with #10 x 1/2" (13 mm) long sheet metal screws.

E. 211A™-09 AND LARGER ONLY

1. The boilers have multiple intermediate jacket panels.
2. Collect the jacket cartons listed in Table 6.1. When installing the jacket panels, place them on boiler in the order shown in Figure 6.3.
3. Open the cartons in the order listed in Figure 6.3.
4. Install the Jacket Front Panels:
 - Make sure to slip the Front Panels into the Front Panel Support Brackets (mounted on the base). See Figure 6.2.
 - Install the first Front Panel with the left edge over the Left Front Corner Panel. Line up the holes and secure with #10 x 1/2" (13 mm) long sheet metal screws.
 - Continue applying Front Panels this way.

- Slip the right edge of the last Front Panel under the Right Front Corner Panel. Line up the holes and secure with #10 x 1/2" (13 mm) long sheet metal screws.
5. Install the Jacket Rear Panels:
 - Slip the offset flange of the first Upper Rear Panel under the edge of the Left Rear Corner Panel. Secure with #10 x 1/2" (13 mm) long sheet metal screws.
 - Attach the first Lower Rear Panel in the same way.
 - Attach a Rear Panel Support Leg on the inside of the Upper Rear Panel. The flanges point toward the boiler. Attach with #10 x 1/2" (13 mm) long sheet metal screws.
 - Install a Panel Support Angle on the inside top of the Upper Rear Panel (See Figure 6.2). Use #10 x 1/2" (13 mm) long sheet metal screws.
 - Install the remaining Upper Rear and Lower Rear Panels in the same way.
 - Place the edge of the last rear panel over the Right Rear Corner Panel.
 6. Install the Draft Hood Sections:
 - Start from the left of the boiler (facing the front). Apply the Draft Hood sections from left to right in the order given in Table 6.2.
 - Use two #10 x 1/2" (13 mm) long sheet metal screws for each Flue Collector section.

F. APPLY JACKET TOP PANELS

1. Apply the jacket top panels working from left to right (facing front of boiler). Place the panels from the cartons in the sequence given in Figure 6.3.
2. Mount a Panel Support Angle (GG-6027) on the back bottom edge of each Top Panel with the long flange pointed down. Peel the insulation slightly away from the back edge of the panel for better contact. Secure with one #10 x 1/2" (13 mm) long sheet metal screw.
3. Slide the left hand offset flange of the first Top Panel under the Top Left End Panel. Place the front flange of

the Top Panel over the Front Panel. Line up the holes and secure with #10 x 1/2" (13 mm) long sheet metal screws.

4. Slide the left hand edge of each additional panel under the panel to its left. Secure with #10 x 1/2" (13 mm) long sheet metal screws.
5. Apply the last Top Panel in the same way. Place its right hand edge over the Top Right End Panel. Secure with #10 x 1/2" (13 mm) long sheet metal screws.
6. Check for loose or missing screws as you complete the jacket assembly.

G. APPLY LOWER END PANELS

1. THIS APPLIES TO ALL BOILER SIZES.
2. The parts are packed in carton #12.
3. Attach an End Panel Cover Plate to the opening in the Lower End Panel (GG-6022) if the tapping in the boiler is not being used. Secure with two #10 x 1/2" (13 mm) long metal screws.
4. Apply a Lower End Panel to each end of the boiler, securing to the Corner Panels with eight #10 x 1/2" (13 mm) long sheet metal screws. Attach to the Upper End Panels with two #10 x 1/2" (13 mm) long sheet metal screws.

H. APPLY PLATES AND LABELS

1. Mount Boiler Rating Label, Agency Plates and Caution Labels in the Upper Right End Jacket Panel.
2. Plates to be field applied are packed in Box Number 7.
3. Place these plates as shown in Figure 6.1.
4. Secure metal plates with #6 x 6 mm (1/4") sheet metal screws. Apply all adhesive-backed labels.

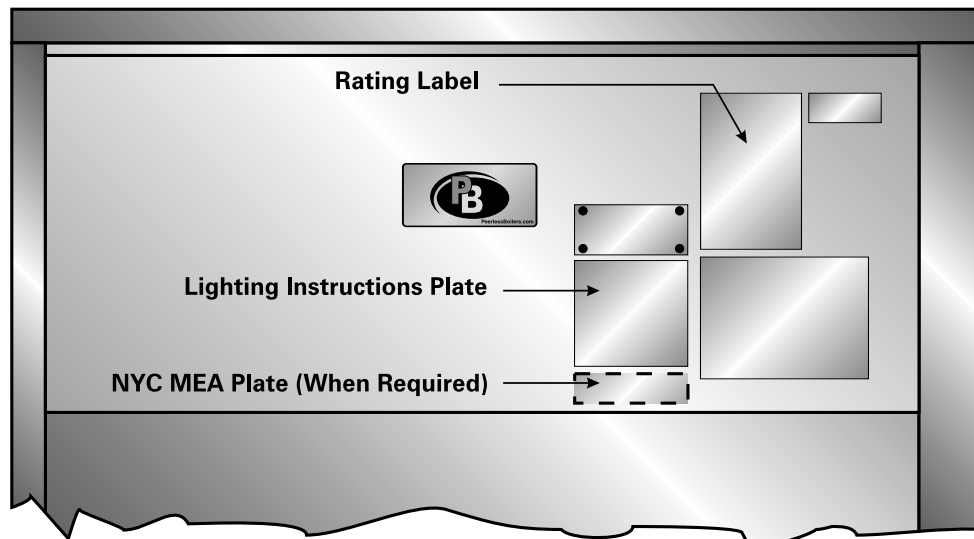

Figure 6.1: Location of Rating, Agency and Instruction Plates on Upper Right End Panel

INSTALL THE JACKET & DRAFT HOOD

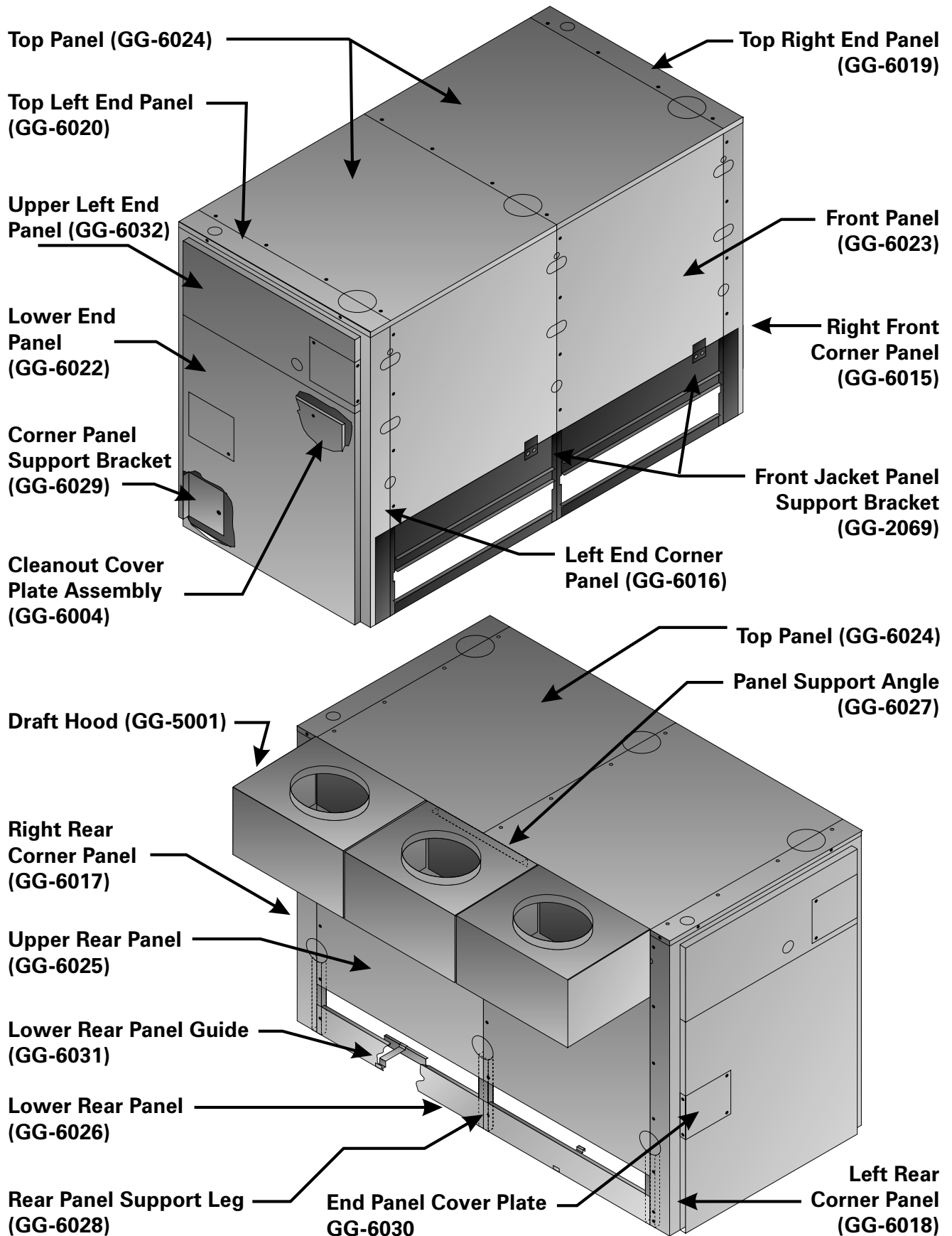

Figure 6.2: Jacket Assembly

Table 6.1: Jacket and Draft Hood Carton Contents – See Figure 6.2 for Placement of Jacket Sections

Carton	Contents	Sub-Assembly	Part Number	Quantity
12	Cleanout Cover Plates	GG-6033	GG-6004	2
	Jacket Corner Panel, Right Front		GG-6015	1
	Jacket Corner Panel, Left Front		GG-6016	1
	Jacket Corner Panel, Right Rear		GG-6017	1
	Jacket Corner Panel, Left Rear		GG-6018	1
	Corner Panel Support Brackets		GG-6029	4
	Jacket Upper End Panel, Left		GG-6032	1
	Jacket Upper End Panel, Right		GG6021	1
	End Panel Cover Plates		GG-6030	4
	Jacket Lower End Panels		GG-6022	2
	Top Right End Panel		GG-6019	1
	Top Left End Panel		GG-6020	1
	Sheet Metal Screws		—	
	Machine Screws, Washers, Nuts		—	
12A	Jacket Intermediate Panel – Front	GG-6034	GG-6023	1
	Jacket Intermediate Panel – Top		GG-6024	1
	Jacket Intermediate Panel – Upper Rear		GG-6025	1
	Jacket Intermediate Panel – Lower Rear		GG-6026	1
	Panel Support Angle		GG-6027	2
	Rear Panel Support Leg		GG-6028	1
	Lower Rear Panel Guide		GG-6031	1
	Sheet Metal Screws		—	23
12B	Jacket Intermediate Panel – Front	GG-6034-1	GG-6023-1	1
	Jacket Intermediate Panel – Top		GG-6024-1	1
	Jacket Intermediate Panel – Upper Rear		GG-6025-1	1
	Jacket Intermediate Panel – Lower Rear		GG-6026-1	1
	Panel Support Angle		GG-6027	2
	Rear Panel Support Leg		GG-6028	1
	Lower Rear Panel Guide		GG-6031	1
	Sheet Metal Screws		—	23
12C	Jacket Intermediate Panel – Front	GG-6034-2	GG-6023-2	1
	Jacket Intermediate Panel – Top		GG-6024-2	1
	Jacket Intermediate Panel – Upper Rear		GG-6025-2	1
	Jacket Intermediate Panel – Lower Rear		GG-6026-2	1
	Panel Support Angle		GG-6027	2
	Rear Panel Support Leg		GG-6028	1
	Lower Rear Panel Guide		GG-6031	1
	Sheet Metal Screws		—	23
12D	Jacket Intermediate Panel – Front	GG-6034-3	GG-6023-3	1
	Jacket Intermediate Panel – Top		GG-6024-3	1
	Jacket Intermediate Panel – Upper Rear		GG-6025-3	1
	Jacket Intermediate Panel – Lower Rear		GG-6026-3	1
	Panel Support Angle		GG-6027	2
	Rear Panel Support Leg		GG-6028	1
	Lower Rear Panel Guide		GG-6031	1
	Sheet Metal Screws		—	23
12E	Jacket Intermediate Panel – Front	GG-6034-4	GG-6023-4	1
	Jacket Intermediate Panel – Top		GG-6024-4	1
	Jacket Intermediate Panel – Upper Rear		GG-6025-4	1
	Jacket Intermediate Panel – Lower Rear		GG-6026-4	1
	Panel Support Angle		GG-6027	2
	Rear Panel Support Leg		GG-6028	1
	Lower Rear Panel Guide		GG-6031	1
	Sheet Metal Screws		—	23
13	Draft Hood Section	GG-5001	GG-5001	1
	Sheet Metal Screws		—	
13A	Draft Hood Section	GG-5001-1	GG-5001-1	1
	Sheet Metal Screws		—	
13B	Draft Hood Section	GG-5001-2	GG-5001-2	1
	Sheet Metal Screws		—	
13C	Draft Hood Section	GG-5001-3	GG-5001-3	1
	Sheet Metal Screws		—	

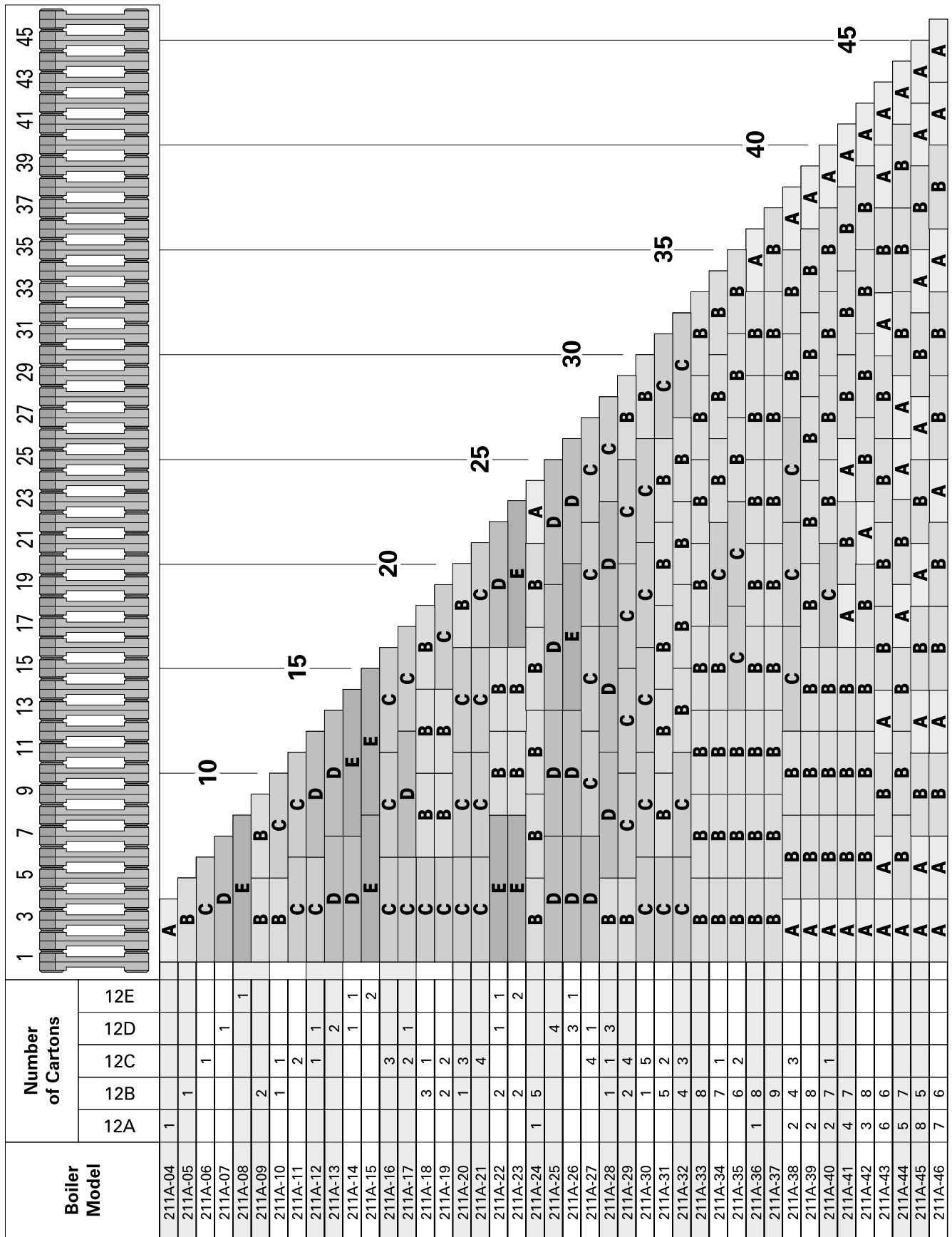

Figure 6.3: Jacket Assembly Sequence - Carton Numbers and Locations

Table 6.2: Draft Hood Section Placement (from Left to Right Facing Front of Boiler)

Boiler Model Number	Position 1	Position 2	Position 3	Position 4	Position 5	Position 6	Position 7	Position 8	Position 9
211A-04	13	—	—	—	—	—	—	—	—
211A-05	13A	—	—	—	—	—	—	—	—
211A-06	13C	—	—	—	—	—	—	—	—
211A-07	13	13	—	—	—	—	—	—	—
211A-08	13A	13	—	—	—	—	—	—	—
211A-09	13A	13A	—	—	—	—	—	—	—
211A-10	13C	13B	—	—	—	—	—	—	—
211A-11	13C	13C	—	—	—	—	—	—	—
211A-12	13A	13A	13	—	—	—	—	—	—
211A-13	13A	13A	13A	—	—	—	—	—	—
211A-14	13C	13B	13B	—	—	—	—	—	—
211A-15	13C	13B	13C	—	—	—	—	—	—
211A-16	13C	13C	13C	—	—	—	—	—	—
211A-17	13B	13B	13B	13B	—	—	—	—	—
211A-18	13C	13B	13B	13B	—	—	—	—	—
211A-19	13B	13C	13C	13B	—	—	—	—	—
211A-20	13C	13C	13C	13B	—	—	—	—	—
211A-21	13C	13C	13C	13C	—	—	—	—	—
211A-22	13C	13B	13B	13B	13B	—	—	—	—
211A-23	13C	13C	13B	13B	13B	—	—	—	—
211A-24	13C	13C	13C	13B	13B	—	—	—	—
211A-25	13C	13C	13C	13C	13B	—	—	—	—
211A-26	13C	13C	13C	13C	13C	—	—	—	—
211A-27	13C	13C	13B	13B	13B	13B	—	—	—
211A-28	13C	13C	13C	13B	13B	13B	—	—	—
211A-29	13C	13C	13C	13C	13B	13B	—	—	—
211A-30	13C	13C	13C	13C	13C	13B	—	—	—
211A-31	13C	13C	13C	13C	13C	13C	—	—	—
211A-32	13C	13C	13C	13B	13B	13B	13B	—	—
211A-33	13C	13C	13C	13C	13B	13B	13B	—	—
211A-34	13C	13C	13C	13C	13C	13B	13B	—	—
211A-35	13C	13C	13C	13C	13C	13C	13B	—	—
211A-36	13C	13C	13C	13C	13C	13C	13C	—	—
211A-37	13C	13C	13C	13C	13B	13B	13B	13B	—
211A-38	13B	13B	13B	13C	13C	13C	13C	13C	—
211A-39	13B	13B	13C	13C	13C	13C	13C	13C	—
211A-40	13B	13C	13C	13C	13C	13C	13C	13C	—
211A-41	13C	13C	13C	13C	13C	13C	13C	13C	—
211A-42	13B	13B	13B	13B	13C	13C	13C	13C	13C
211A-43	13B	13B	13B	13C	13C	13C	13C	13C	13C
211A-44	13B	13B	13C	13C	13C	13C	13C	13C	13C
211A-45	13B	13C	13C	13C	13C	13C	13C	13C	13C
211A-46	13C	13C	13C	13C	13C	13C	13C	13C	13C

7. CONNECT GAS PIPING

A. INSTALL GAS TRAIN

- The Gas Control Train(s) supplied with this boiler:
 - Has been factory assembled and tested for tightness of joints.
 - Must be re-tested after installation with a soap suds test to assure it is still leak-tight after assembly.
 - Must be isolated from the gas supply piping during testing of the supply piping.
- Assemble the Gas Control Train(s) to the Manifold with the ground joint union(s) provided. See Figure 7.1. Models 211A™-04 through 211A™-18 are supplied with a single Gas Control Train. Models 211A™-19 and larger are supplied with two or more Gas Control Trains.
- Support the Gas Control Train(s) with a permanent brace.

B. CONNECT PILOT GAS TUBING

- Use 3/8" aluminum tubing or as required by local codes.
- Connect the Pilot Line to the Pilot Cock Assembly supplied with the Gas Control Train.

- Connect tubing to each pilot.
 - Connect electronic pilots to the Pilot Gas Valves.
 - Connect standing pilots (when supplied – see Table 2.2) to the thermopilot valves.
 - Install thermocouples in the standing pilots and connect to the thermopilot valves.

C. INSTALL VENT AND BLEED PIPING

- Gas Pressure Regulator
 - Connect regulator vent outlet to outside atmosphere using 1/4" tubing or as required by local codes.
 - Terminate the tubing downward to prevent water from entering the tubing and protect from any obstruction.
 - Terminate the tubing above and well away from normal breathing level or building air intakes.
- Diaphragm Gas Valves
 - Pipe diaphragm gas valve bleed lines to outside atmosphere.
 - Use 1/4" tubing or as required by local codes. Always pipe the bleed lines separate from the regulator vent lines.

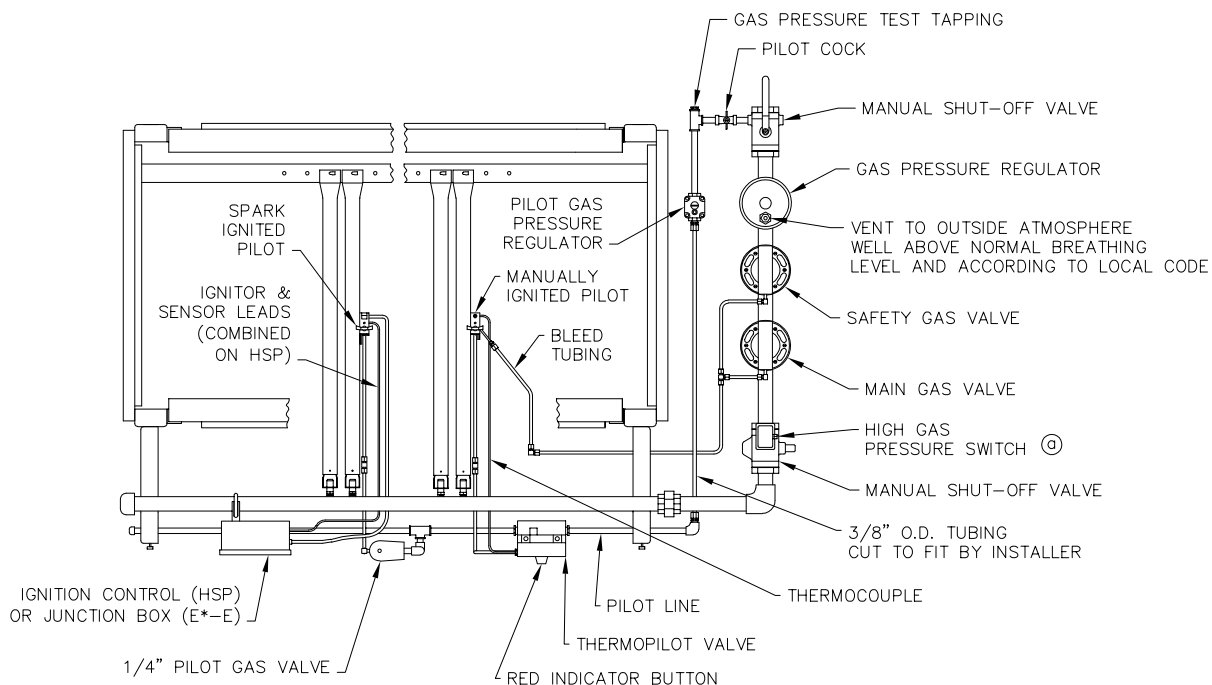

NOTES:

⊙ – REQUIRED ON BOILERS WITH AN INPUT OF 2500 MBH (733kw) OR MORE.

Figure 7.1: Gas Control Train and Burner Assembly, Single Natural Gas Control Train Shown (Models 211A™-19 and Larger Use Two or More Gas Control Trains)

- c. When piping bleed lines to outside, terminate the tubing downward to prevent water from entering the tubing, and protect the tubing termination from any obstruction. Terminate the tubing above and well away from normal breathing level or building air intakes.

D. INSTALL GAS SUPPLY PIPING

1. Size the piping as required by the National Fuel Gas Code, ANSI Z223.1/NFPA 54 and/or CAN/CGA B149 Installation Codes or as required by local codes.
 - a. Use Table 7.1 for sizing of natural gas for a system pressure drop of 0.3 inch water column (75 Pa).

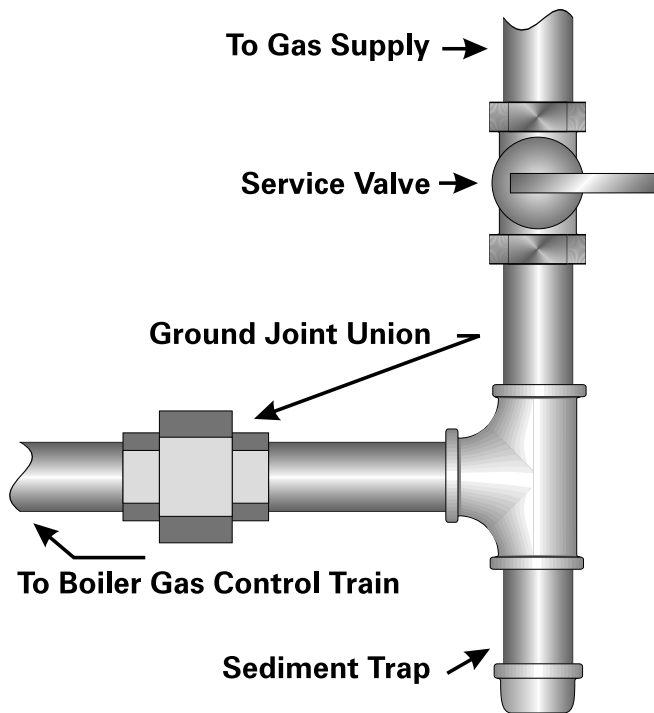

Figure 7.2: Gas Supply Connection to Boiler

2. The standard gas train is designed for a maximum pressure of 1/2 psig (14 inches water column/3.5 kPa). Make sure the system regulator will not allow a higher pressure to the Gas Control Train under any conditions.
3. The minimum gas supply pressure is listed on the Boiler Rating Label. Make sure the system regulator and the piping are sized and adjusted properly to provide this pressure under all conditions.
4. Install a Service Valve, Sediment Trap and Ground Joint Union at the supply connection to the Gas Control Train as shown in Figure 7.2. These are not supplied with the boiler. Install them in accordance with local codes.
5. Use only pipe joint compounds rated for use with Liquefied Petroleum Gases. This is necessary because most natural gas contains propane as well as methane.

E. TEST GAS SUPPLY PIPING

1. ISOLATE THE BOILER GAS CONTROL TRAIN FROM THE SYSTEM DURING TEST:
 - a. Test pressure 1/2 psig (3.5 kPa) or less – Close the Manual Shut-Off Valve on the Boiler Gas Control Train
 - b. Test pressure over 1/2 psig (3.5 kPa) – Disconnect the gas supply piping upstream of the Boiler Manual Shut-Off Valve

⚠ WARNING

Do not expose the Gas Control Train to excessive pressure. The gas valves can be damaged. This could result in explosion hazard and severe personal injury or death.

Do not test gas supply piping with open flame. Use a soap suds mixture brushed onto the pipe joints to test for leaks.

CONNECT GAS PIPING

Table 7.1: Capacity of Gas Supply Pipe in Cubic Feet (Cubic Meters) Per Hour of Natural Gas for 0.3 inch (75 Pa) Drop.

Pipe Length		1-1/4" Pipe		1-1/2" Pipe		2" Pipe		2-1/2" Pipe		3" Pipe		4" Pipe		6" Pipe	
Feet	Meters	Foot ³	Meter ³	Foot ³	Meter ³	Foot ³	Meter ³	Foot ³	Meter ³	Foot ³	Meter ³	Foot ³	Meter ³	Foot ³	Meter ³
10	3.0	1050	30	1,600	45	3,050	86	4,800	136	8,500	241	17,500	496	44,000	1246
20	6.1	730	21	1,100	31	2,100	59	3,300	93	5,900	167	12,000	340	31,000	878
30	9.1	590	17	890	25	1,650	47	2,700	76	4,700	133	9,700	275	25,000	708
40	12.2	500	14	760	22	1,450	41	2,300	65	4,100	116	8,300	235	22,000	623
50	15.2	440	12	670	19	1,270	36	2,000	57	3,600	102	7,400	210	20,000	566
60	18.3	400	11	610	17	1,150	33	1,850	52	3,250	92	6,800	193	18,000	510
70	21.3	350	10	560	16	1,050	30	1,700	48	3,000	85	6,200	176	17,000	481
90	27.4	320	9	490	14	930	26	1,500	42	2,600	74	5,400	153	15,000	425
100	30.5	305	9	460	13	870	25	1,400	40	2,500	71	5,100	144	14,000	396
150	45.7	250	7	380	11	710	20	1,130	32	2,000	57	4,100	116	11,500	326

Above ratings based on natural gas with specific gravity of 0.60 allowing pressure drop of 0.3 inches (75 Pa). No allowance is needed for pipe fittings. Use the following multipliers on above capacities for specific gravity other than 0.60:

Specific Gravity	0.50	0.55	0.60	0.65	0.70
Multiply Capacity by:	1.10	1.04	1.00	.962	.926

8. INSTALL CONTROLS & TRIM

A. INSTALL SAFETY VALVE(S)

1. Pipe the pop safety valve(s) in the 3" tapping located on the right or left end sections. Make sure the relief valve sizing meets local code requirements.

⚠ CAUTION

Pipe the discharge of the Safety Relief Valve(s) away from any traffic area, preferably to a floor drain. This is necessary to prevent injury should the valve discharge. Pipe the discharge full size of valve outlet.

B. INSTALL BLOWDOWN VALVES

1. Install a 1-1/2" full port ball valve in each of the tapings provided at the lower back of the end sections. See Figure 8.1.
2. Pipe the valve discharge to a floor drain if available or apply a nipple and cap to close off when not in use.

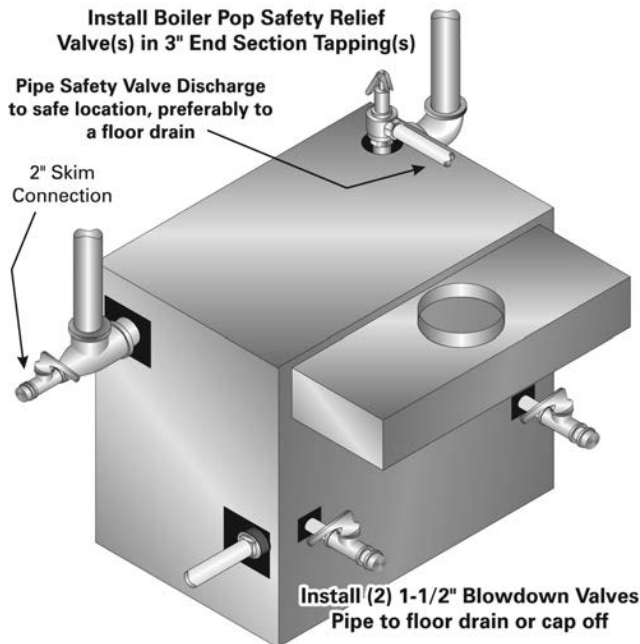

Figure 8.1: Blowdown Valve Piping

C. INSTALL LOW WATER CUT-OFF(S)

1. Mount the float type low water cut-off and gauge glass in the tapings provided in the front of either end section.
2. Do not apply piping which would raise or lower the location of the cut-off relative to the tapings in the boiler. Raising the water level over the design height will cause water carryover to the system.
3. For correct location of typical low water cut-off/feeder or low water cut-off/pump control, see Figures 8.3 through 8.6.
4. Mount the probe type low water cut-off supplied with the boiler. The end sections have 3/4" tapings in the front for mounting the probe low water cut-off auxiliary control. See Figure 3.3.
 - a. The standard probe control is Hydrolevel Model 650P. This control is automatic reset type.
 - b. When a manual reset control is required, the boiler can be supplied with Hydrolevel Model 550P.
5. Provide each float low water cut-off with a blowdown valve. Pipe the blowdown away from traffic to a floor drain if available. The blowdown valve is required for proper maintenance of the control.
6. Maintain a height of 40-1/2" (1029 mm) from boiler foundation to the normal water level.
7. When using multiple float type Controls: Always pipe the controls off of the same tapings to the boiler. Do not mount on different ends of the boiler or in different tapings. This can cause erratic operation and nuisance problems with the controls.

D. INSTALL PRESSURE CONTROLS

1. Pipe the Steam Pressure Gauge and Boiler Limit and Operating Pressure Controls as shown in Figure 8.2. Connect the control assembly to the 1/2" tapping on the right end of the boiler.

⚠ CAUTION

Make sure that the gas ignition system components, electrical controls, junction boxes and electrical panels are protected from water (dripping, spraying, rain, etc.) during boiler operation and service (circulator or pump servicing, control replacements or other).

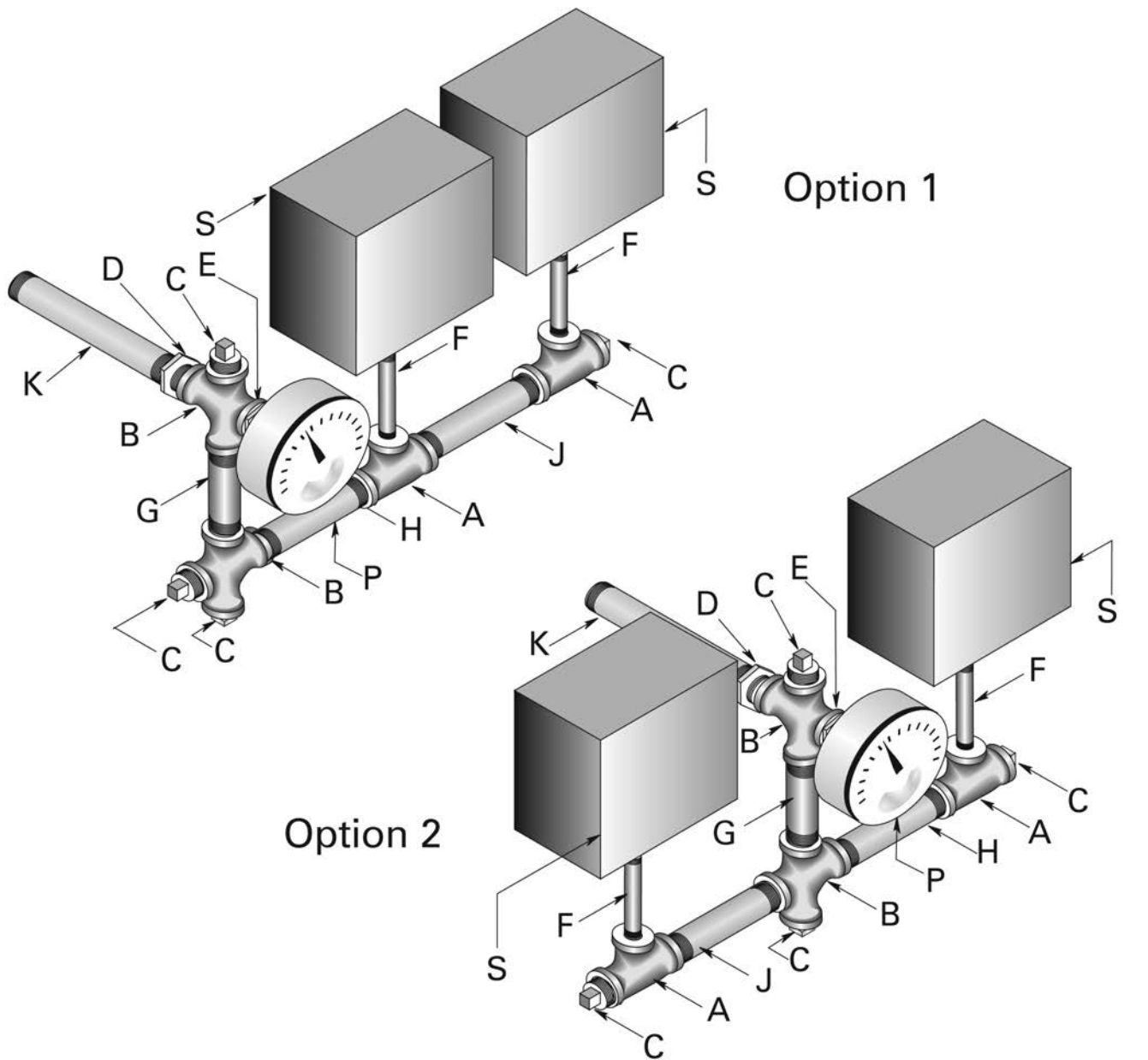

- | | | | |
|---|-------------------------------------|---|--------------------------------------|
| A | 3/4" X 3/4" X 1/4" Reducing Tee | G | 3/4" x 3" (76 mm) long Nipple |
| B | 3/4" Cross | H | 3/4" x 4" (102 mm) long Nipple |
| C | 3/4" Plug | J | 3/4" x 5" (127 mm) long Nipple |
| D | 3/4" x 1/2" Hex Bushing | K | 1/2" x 6" (152 mm) long Brass Nipple |
| E | 3/4" x 1/4" Hex Bushing | P | Steam Gauge |
| F | 1/4" x 3" (76 mm) long Brass Nipple | S | Pressuretrols |

(Right Hand Shown, Left Hand Opposite)

(NOTE: Some local codes may require larger piping)

Figure 8.2: Pressure Control Piping (Fittings Included with Boiler)

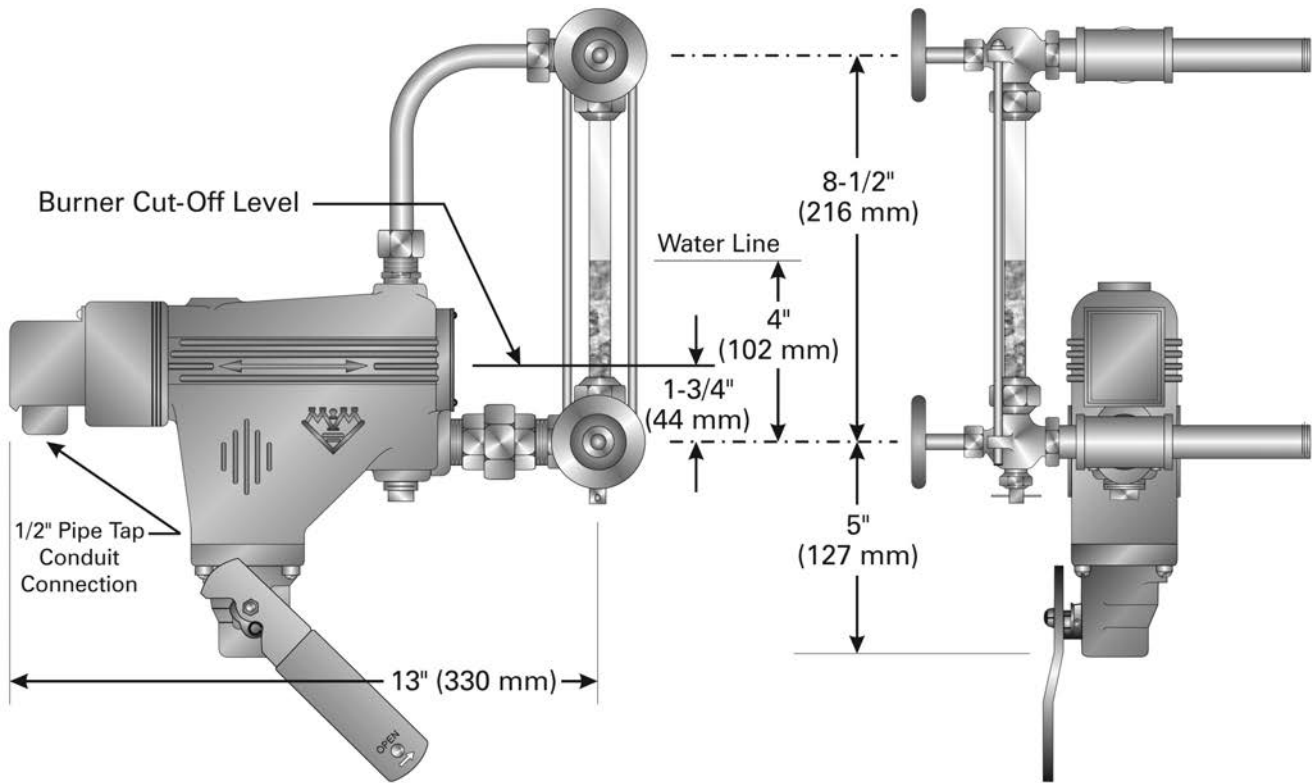

Figure 8.3: Standard Float Type Control, Model 67PE2

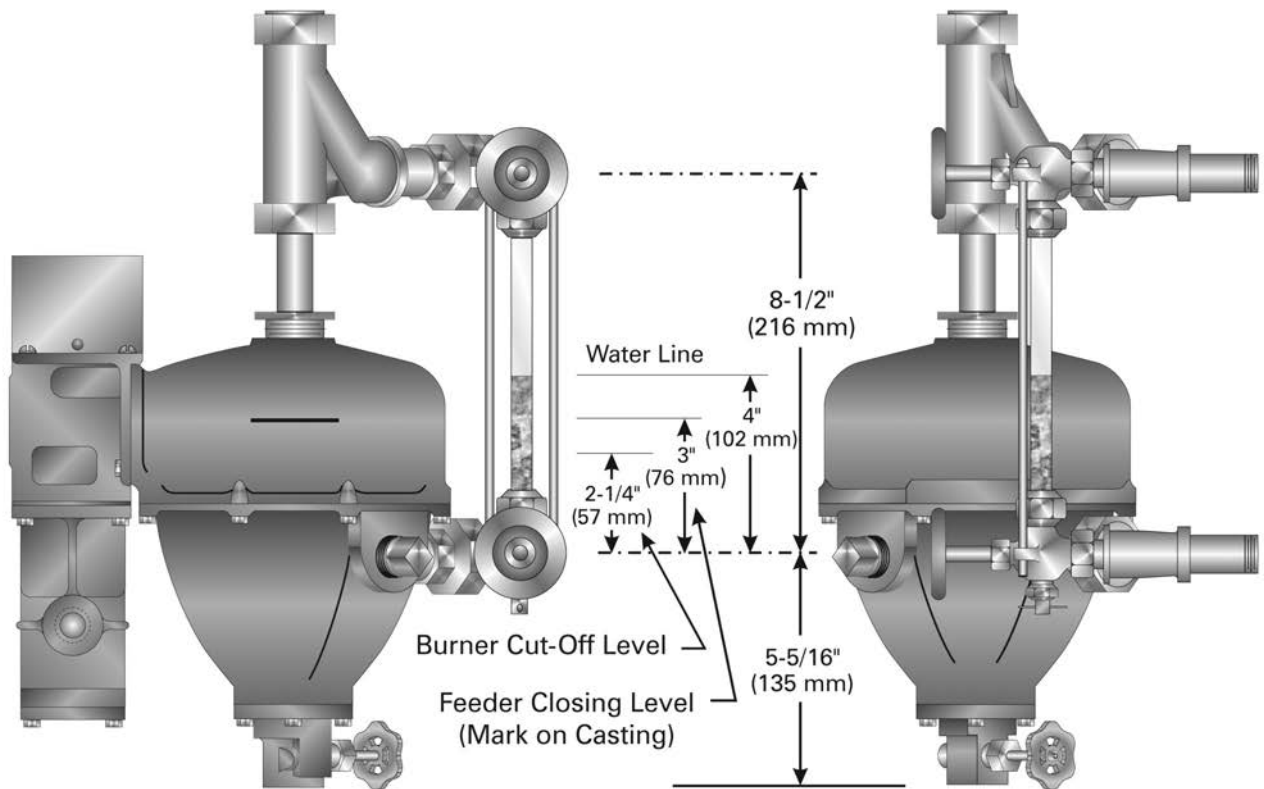
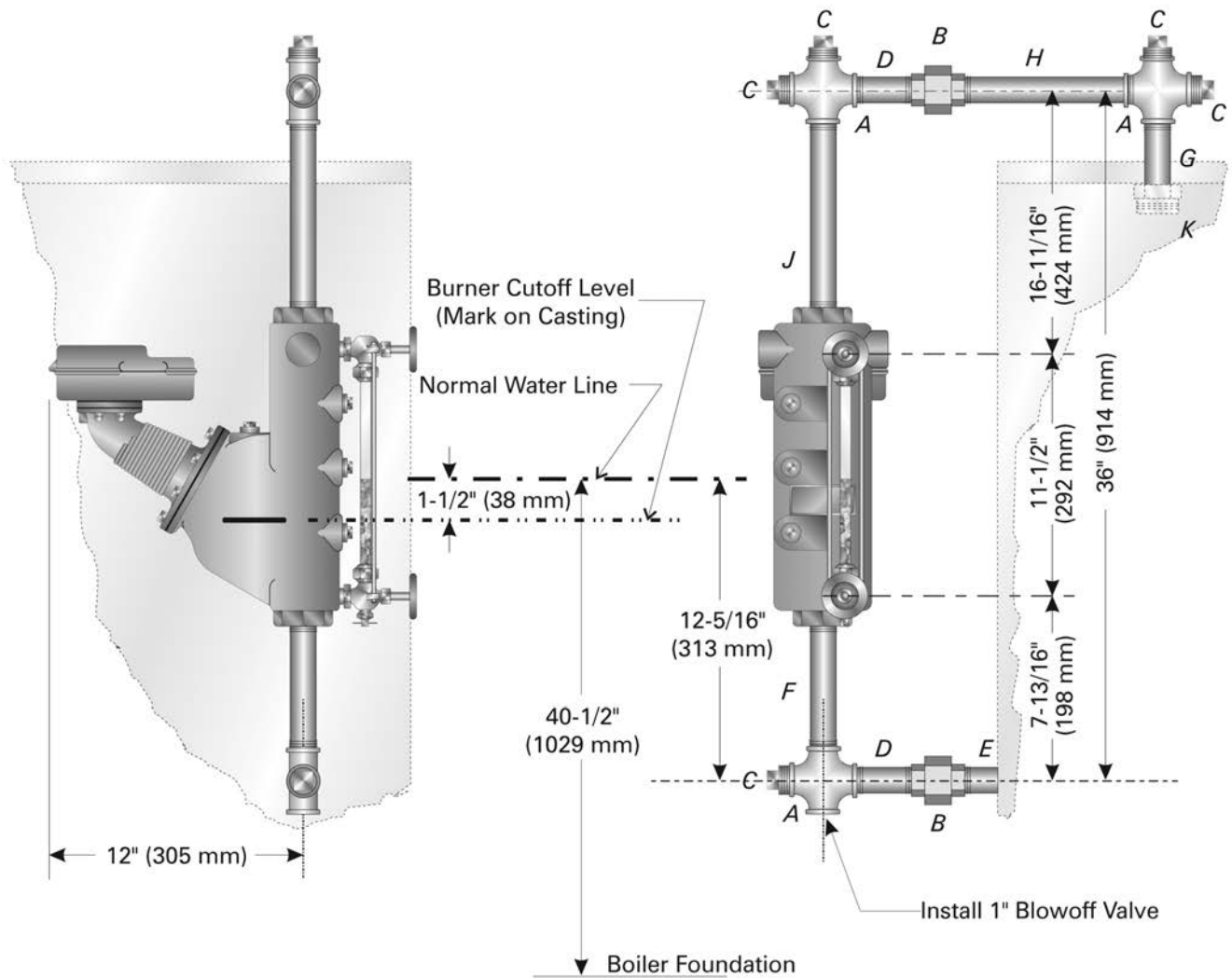

Figure 8.4: Optional Feeder/Low Water Cut-Off, Model 47-2 – Used Only on Models 211A™-04 through 211A™-08 – Capacity Not Adequate for Larger Boilers



SUGGESTED FITTINGS LIST

<i>A</i>	1" Cross	<i>F</i>	1" x 6" (152 mm) long Nipple
<i>B</i>	1" Ground Joint Union	<i>G</i>	1" x 8" (203 mm) long Nipple
<i>C</i>	1" Plug	<i>H</i>	1" x 8-1/4" (210 mm) long Nipple
<i>D</i>	1" x 2" (51 mm) long Nipple	<i>J</i>	1" x 14" (356 mm) long Nipple
<i>E</i>	1" x 3" (76 mm) long Nipple	<i>K</i>	3" x 1" Bushing

The connected fittings shown on this drawing are to be supplied by the installer.

Figure 8.5: Optional Float Type Pump Control/Low Water Cut-Off, Model 157

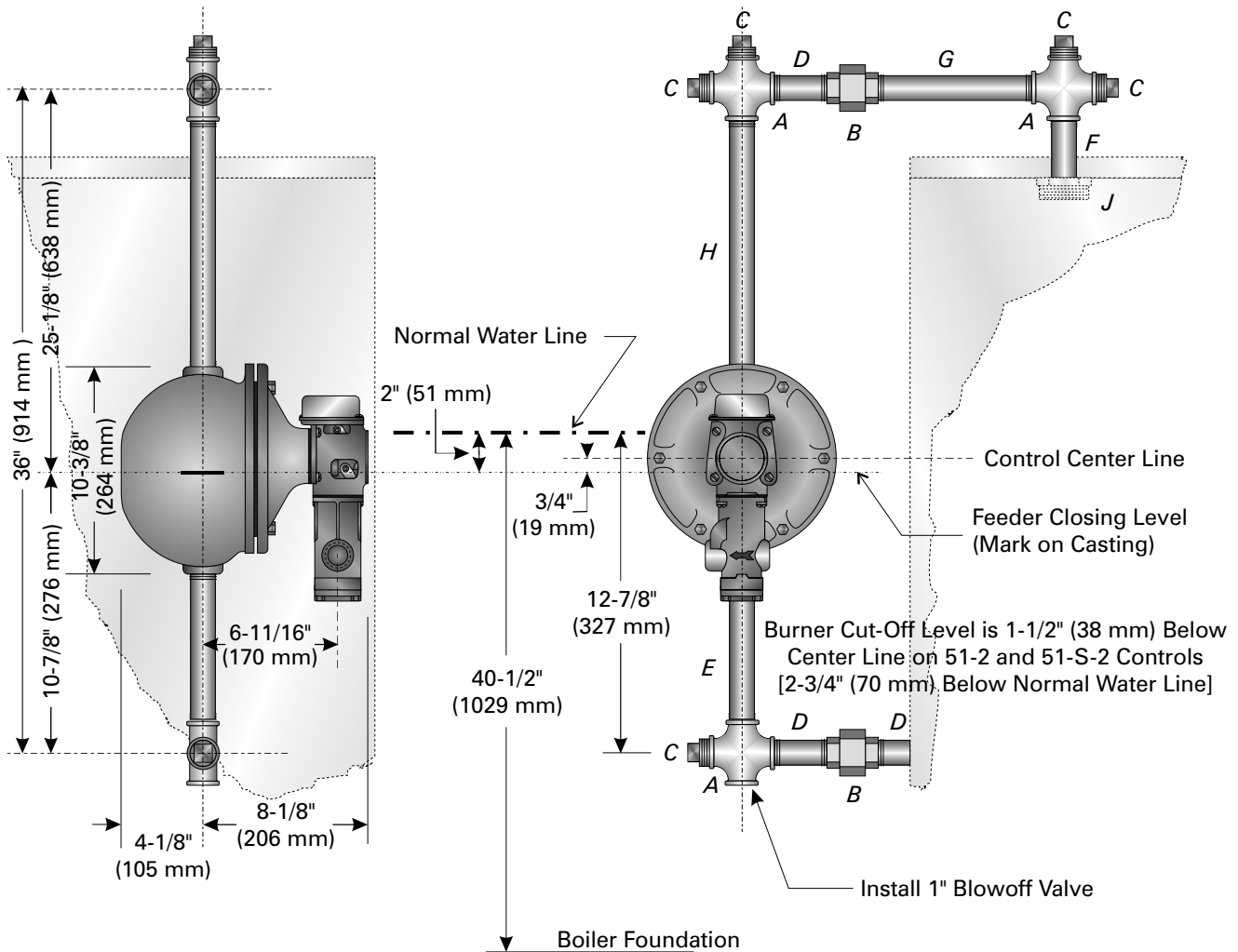

APPLICATION OF 51 FEEDERS

Models 211A-04 thru 211A-23
One 51-2 Feeder/Cutoff

Models 211A-24 thru 211A-39
One 51-S-2 Feeder/Cutoff

Models 211A-40 and Larger
Two 51-2 Feeder/Cutoffs

Consult Factory for proper application of feeders.
Always use a pump control and boiler feed system
instead when possible.

SUGGESTED FITTINGS LIST

- A 1" Cross
- B 1" Ground Joint Union
- C 1" Plug
- D 1" x 3" (76 mm) long Nipple
- E 1" x 5-1/2" (140 mm) long Nipple
- F 1" x 8" (203 mm) long Nipple
- G 1" x 8-1/4" (210 mm) long Nipple
- H 1" x 19-1/2" (495 mm) long Nipple
- J 3" x 1" Bushing

The connected fittings shown on this
drawing are to be supplied by the installer.

Figure 8.6: Optional Feeder/Low Water Cut-Off, Type 51-2

9. WIRE THE BOILER

A. CONNECT SUPPLY WIRING

1. All wiring must be done in accordance with local codes, the National Electrical Code ANSI/NFPA70 and/or the Canadian Electrical Code Part I, CSA C22.1, Electrical Code and other controlling agencies or governing bodies.

CAUTION

Label all wires prior to disconnection when servicing controls. Wiring errors can cause improper and dangerous operation. Verify proper operation after servicing.

AVERTISSEMENT

Identifier tous les câbles avant de les débrancher au moment d'effectuer l'entretien des commandes. Des erreurs dans le raccordement des câbles d'alimentation peuvent causer un fonctionnement inadéquat et dangereux. Vérifier le bon fonctionnement après les travaux d'entretien.

NOTICE

The boiler/burner must be electrically grounded in accordance with the requirements of the authority having jurisdiction, or in the absence of such requirements, with the current edition of the National Electrical Code, ANSI/NFPA Number 70 and/or the Canadian Electrical Code Part I, CSA C22.1, Electrical Code.

2. Use #14 gauge or heavier wire for supply wiring. Protect the circuit with a fused disconnect switch (by others) and a grounded neutral.
3. Mount an electrical junction box on the boiler Front Panel for connection of supply wiring and distribution to the boiler controls. See Figures 9.1.a and 9.1b.

B. PREPARE REMAINING CONTROLS

1. Mount the control transformer on the junction box as shown in Figures 9.1a and 9.1b.
2. Mount a junction box near each Gas Control Train for connection of conduit and wiring distribution to the gas train components.

C. INSTALL CONTROL WIRING

1. Wire the boiler according to the wiring diagram supplied with the boiler (in the Control Envelope). Figures 9.1a and 9.1b are a typical layout of the components on the boiler. Figures 9.2 through 9.4 are examples of standard wiring systems. Use these drawings for general reference only.
2. Low Energy Safety Control wiring must follow the contour of the boiler. Some local codes may require that all wiring, even low voltage, be routed in conduit.
3. Install all line voltage wiring in conduit.
4. Do not install single pole switches, including safety controls, in a grounded line.

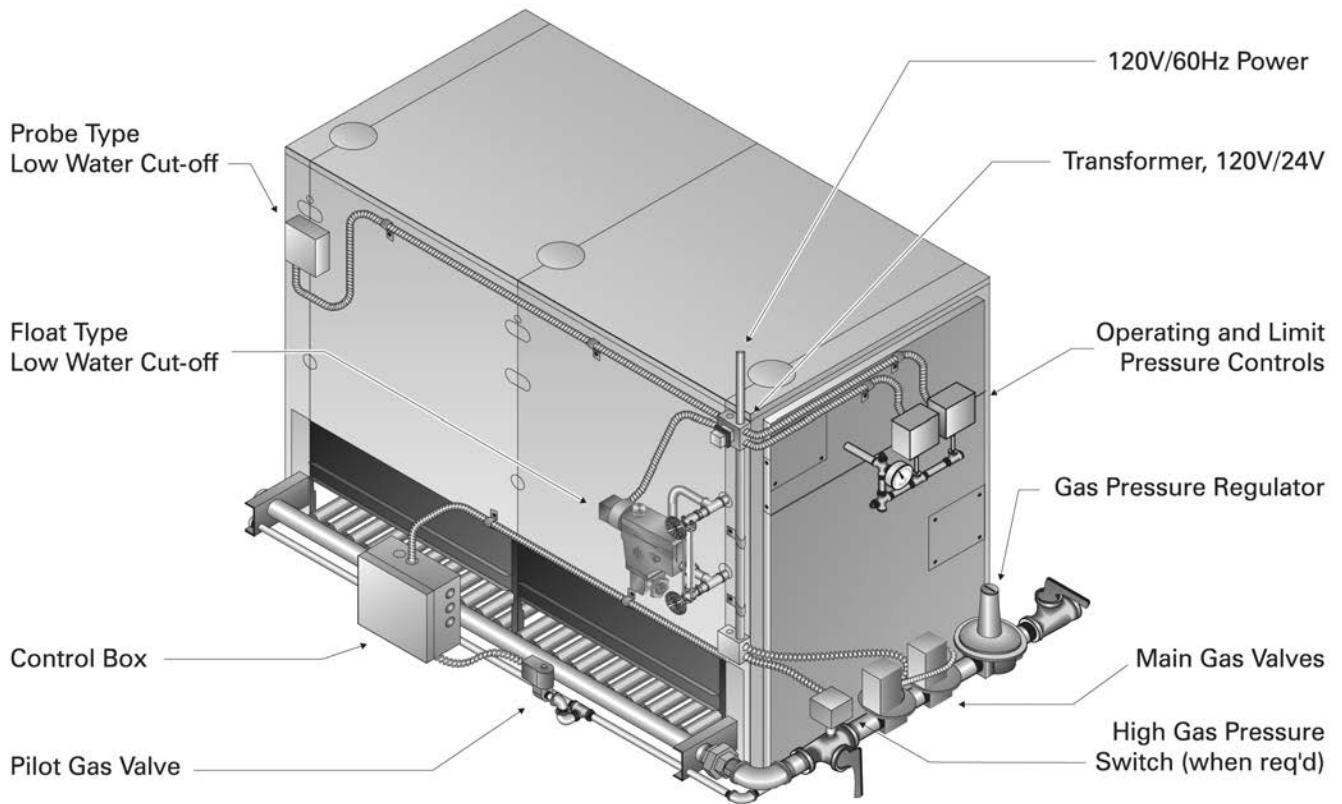

Figure 9.1a: Typical Control Layout and Wiring - HSP Ignition

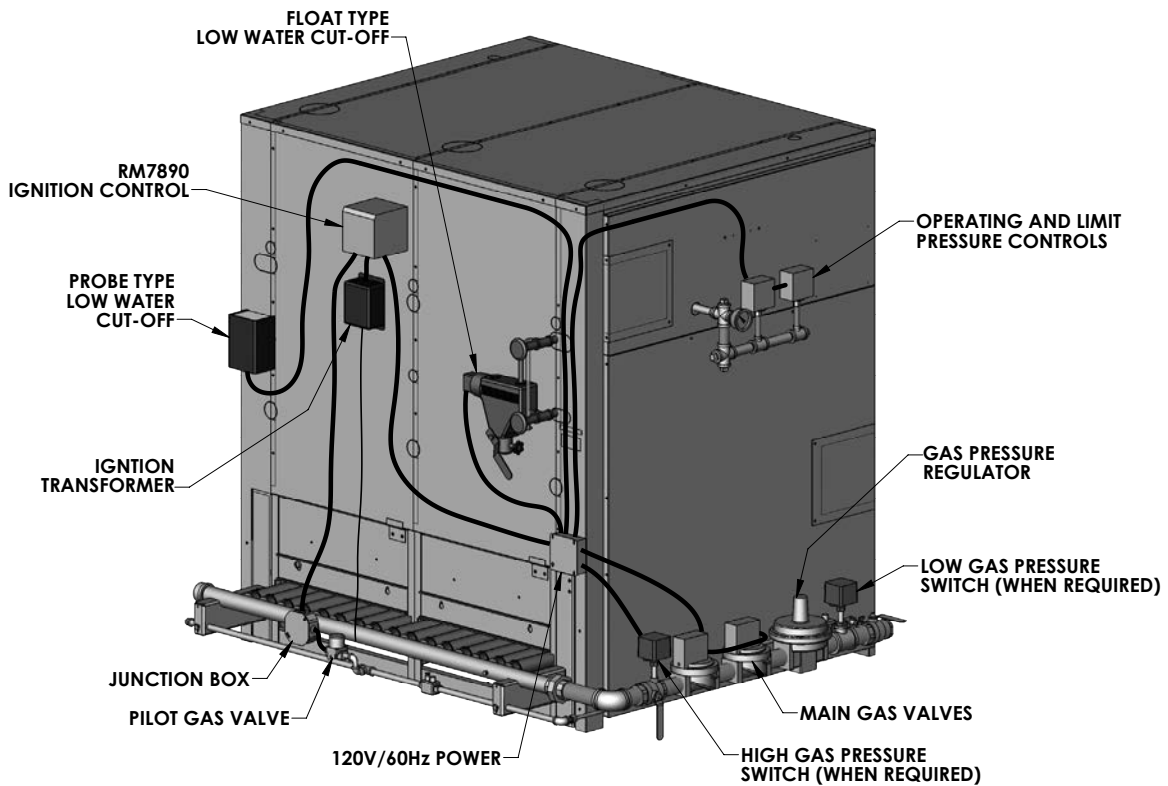
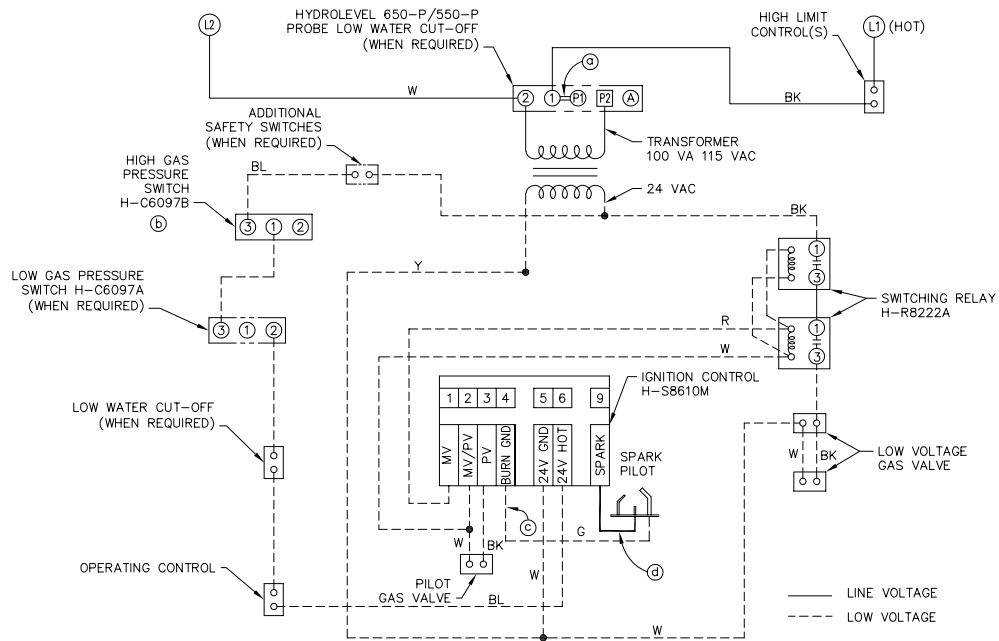

Figure 9.1b: Typical Control Layout and Wiring - E*-E Ignition

WIRE THE BOILER



- NOTES:
- Ⓐ - PLACE JUMPER
 - Ⓑ - HIGH GAS PRESSURE SWITCH H-C6097B REQUIRED ON BOILER MODELS 211A-13 THRU 211A-18.
 - Ⓒ - GROUND LEADWIRE 200°C THERMOPLASTIC, ALL OTHER WIRING 80°C THERMOPLASTIC.
 - Ⓓ - IGNITION AND SENSING CABLE
- 1) ALL WIRING MUST COMPLY WITH APPLICABLE CODES, ORDINANCES AND REGULATIONS.
 - 2) IF ANY OF THE ORIGINAL WIRE AS SUPPLIED WITH THE APPLIANCE MUST BE REPLACED, IT MUST BE REPLACED WITH WIRE AS SHOWN OR ITS EQUIVALENT.
 - 3) DANS LE CAS OÙ LES CÂBLES ORIGINAUX DE CET APPAREIL DEVRAIENT ÊTRE REMPLACÉS, LES CÂBLES DE RECHANGE DOIVENT ÊTRE TELS QUE CEUX ILLUSTRÉS.

Typical Wiring - HSP System - Single Gas Control Train, 24-Volt Gas Valves

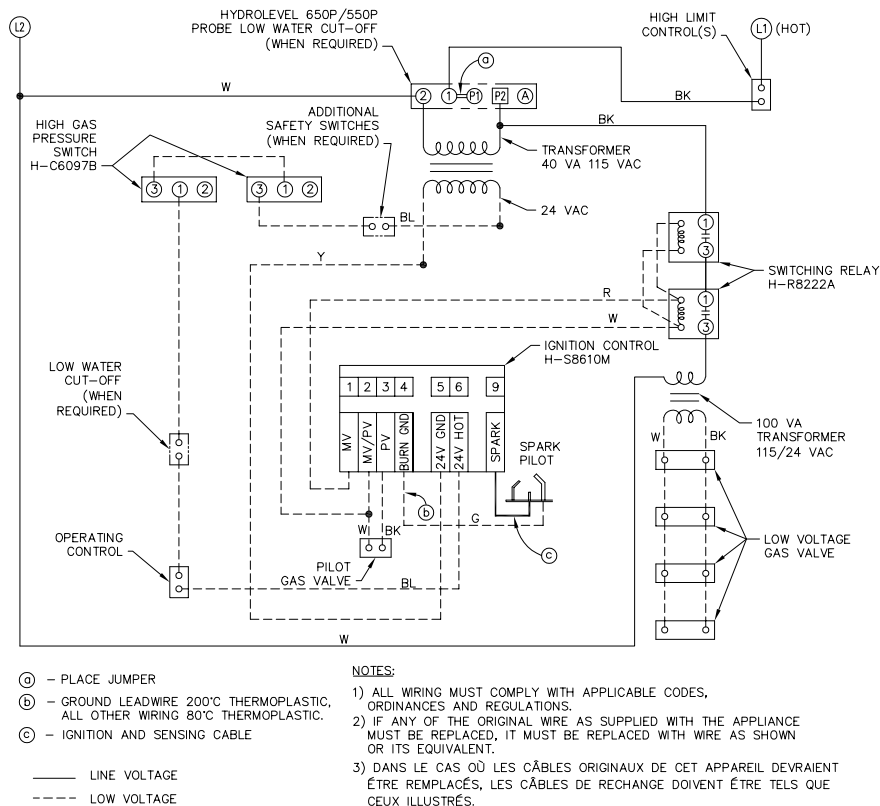

- NOTES:
- Ⓐ - PLACE JUMPER
 - Ⓑ - GROUND LEADWIRE 200°C THERMOPLASTIC, ALL OTHER WIRING 80°C THERMOPLASTIC.
 - Ⓒ - IGNITION AND SENSING CABLE
- 1) ALL WIRING MUST COMPLY WITH APPLICABLE CODES, ORDINANCES AND REGULATIONS.
 - 2) IF ANY OF THE ORIGINAL WIRE AS SUPPLIED WITH THE APPLIANCE MUST BE REPLACED, IT MUST BE REPLACED WITH WIRE AS SHOWN OR ITS EQUIVALENT.
 - 3) DANS LE CAS OÙ LES CÂBLES ORIGINAUX DE CET APPAREIL DEVRAIENT ÊTRE REMPLACÉS, LES CÂBLES DE RECHANGE DOIVENT ÊTRE TELS QUE CEUX ILLUSTRÉS.

Typical Wiring - HSP System - Two Gas Control Trains, 24-Volt Gas Valves

Figure 9.2: Typical Wiring – HSP System – Low Voltage Gas Valves

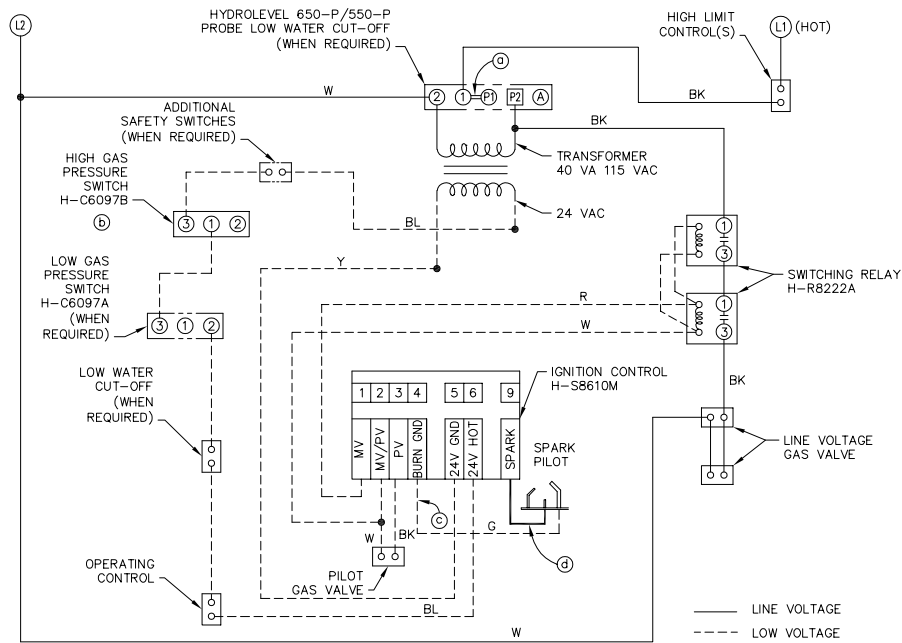

- Ⓐ - PLACE JUMPER
- Ⓑ - HIGH GAS PRESSURE SWITCH H-C6097B REQUIRED ON BOILER MODELS 211A-13 THRU 211A-18.
- Ⓒ - GROUND LEADWIRE 200°C THERMOPLASTIC, ALL OTHER WIRING 80°C THERMOPLASTIC.
- Ⓓ - IGNITION AND SENSING CABLE

NOTES:

- 1) ALL WIRING MUST COMPLY WITH APPLICABLE CODES, ORDINANCES AND REGULATIONS.
- 2) IF ANY OF THE ORIGINAL WIRE AS SUPPLIED WITH THE APPLIANCE MUST BE REPLACED, IT MUST BE REPLACED WITH WIRE AS SHOWN OR ITS EQUIVALENT.
- 3) DANS LE CAS OÙ LES CÂBLES ORIGINAUX DE CET APPAREIL DEVRAIENT ÊTRE REMPLACÉS, LES CÂBLES DE RECHANGE DOIVENT ÊTRE TELS QUE CEUX ILLUSTRÉS.

Typical Wiring - HSP System - Single Gas Control Train, 120-Volt Gas Valves

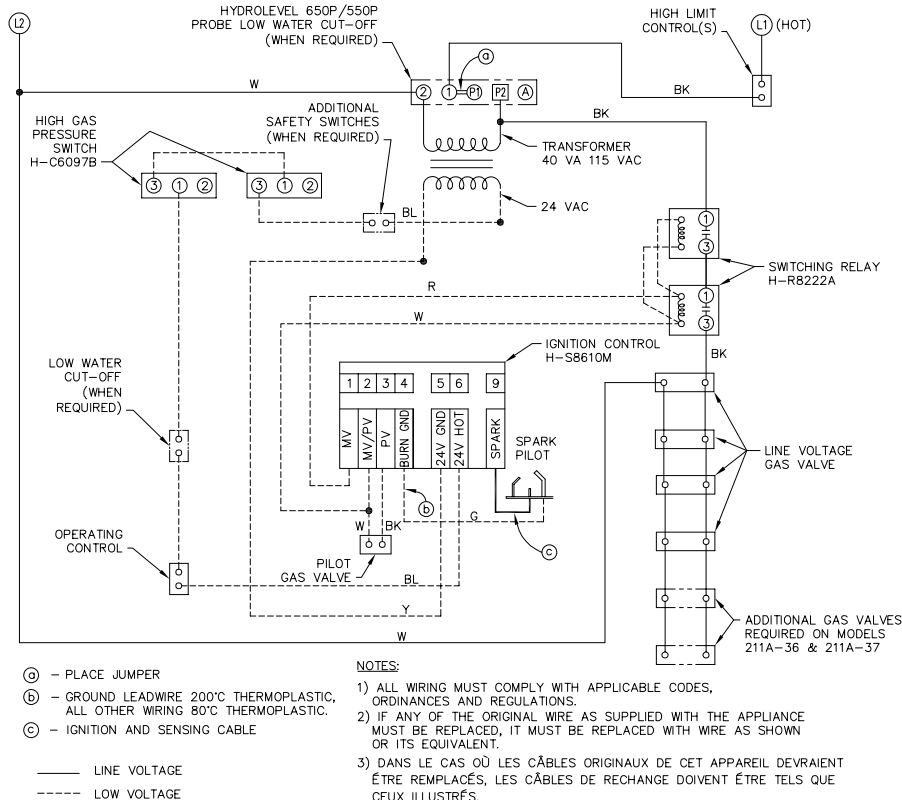

- Ⓐ - PLACE JUMPER
- Ⓑ - GROUND LEADWIRE 200°C THERMOPLASTIC, ALL OTHER WIRING 80°C THERMOPLASTIC.
- Ⓒ - IGNITION AND SENSING CABLE

NOTES:

- 1) ALL WIRING MUST COMPLY WITH APPLICABLE CODES, ORDINANCES AND REGULATIONS.
- 2) IF ANY OF THE ORIGINAL WIRE AS SUPPLIED WITH THE APPLIANCE MUST BE REPLACED, IT MUST BE REPLACED WITH WIRE AS SHOWN OR ITS EQUIVALENT.
- 3) DANS LE CAS OÙ LES CÂBLES ORIGINAUX DE CET APPAREIL DEVRAIENT ÊTRE REMPLACÉS, LES CÂBLES DE RECHANGE DOIVENT ÊTRE TELS QUE CEUX ILLUSTRÉS.

Typical Wiring - HSP System - Two Gas Control Trains, 120-Volt Gas Valves

Figure 9.3: Typical Wiring – HSP System – 120-Volt Gas Valves

WIRE THE BOILER

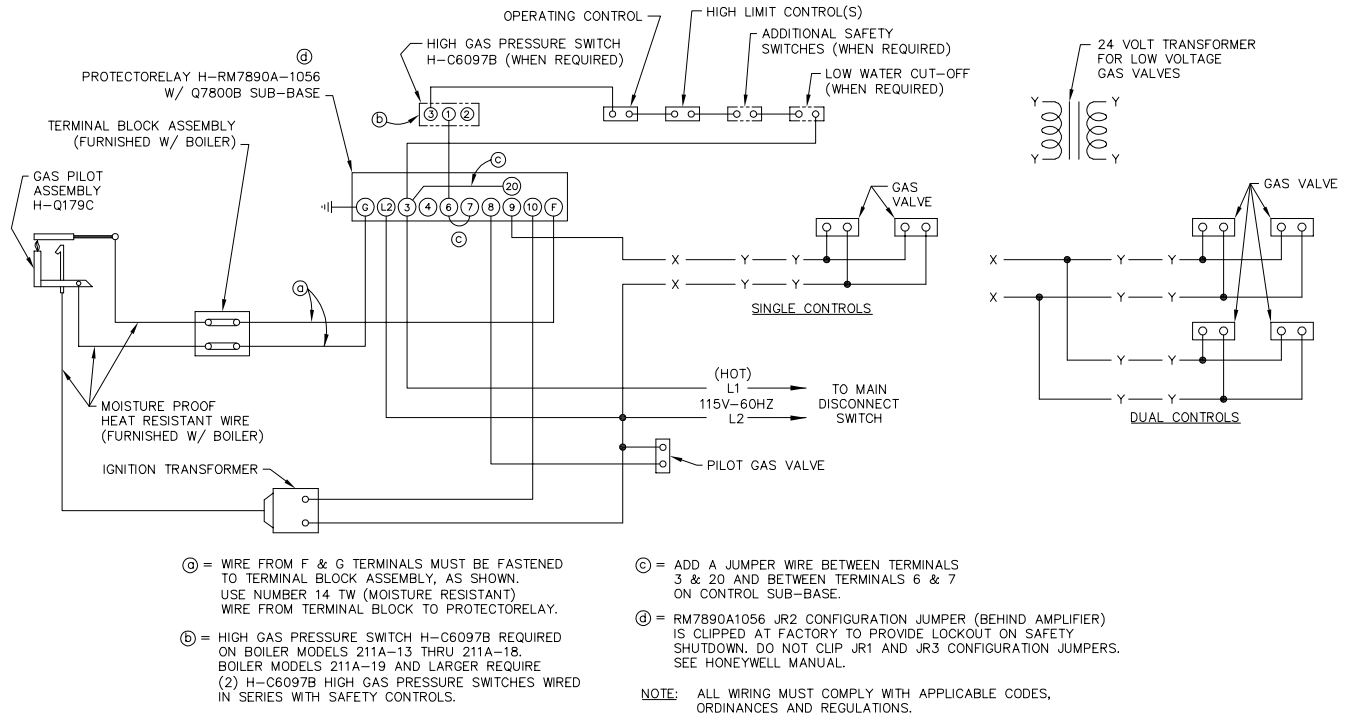

Figure 9.4: Typical Wiring – E1-E Ignition System

10. STARTING THE BOILER

A. CHECK THE PIPING

1. Water and Steam Piping
 - a. The Boiler must have been hydrostatically tested.
 - b. Check the attached piping for joint tightness.
 - c. Continue monitoring as you proceed through start up.
2. Gas Piping
 - a. Make sure the gas system piping and the connections to the boiler Gas Control Train(s) have been leak tested.
 - b. After the boiler is in operation, check the tightness of all joints in the boiler gas piping with a soap suds solution.
 - c. Purge the gas piping of all air up to the boiler Gas Control Train.

B. FILL THE BOILER

1. Fill the boiler to the normal water line.
 - a. Gravity Systems and Pumped Return with Condensate Units-Fill to 40-1/2" (103 cm) above the boiler foundation (center of gauge glass).
 - b. Pumped Return with Boiler Feed Unit-Fill the boiler using the boiler feed unit. Fill level will depend on the control being used, but should be 40-1/2" (103 cm) above the boiler foundation (just below center of gauge glass) when the pump stops.

C. STUDY LIGHTING INSTRUCTIONS

1. Before starting the boiler, study the Lighting Instructions supplied with the boiler.

D. RUN PILOT CHECK-OUT

1. Shut off all electrical power to the boiler.
2. Close Main and Pilot gas shut-off valves. Wait for five (5) minutes.
3. Set the Operating and Limit Pressure Controls to minimum setting so they will not call for heat.
4. Perform Pilot Spark Check:
 - a. Turn main electric disconnect switch to the ON position.
 - b. Turn up the settings on the Operating and Limit Pressure Controls so they will call for heat.
 - c. HSP System (S8610M) - The control will spark for 90 seconds (trial for ignition), then shut down for a 5 to 6 minute wait period before attempting another ignition.
 - d. E*-E Systems (RM7890) - The control will spark for 10 seconds, then lock out. Control will need to be reset.
 - e. Turn down the Operating Pressure Control to stop the call for heat.
 - f. Wait 60 seconds to allow the control to reset before proceeding with the next step.

5. Light Manual Pilots (where equipped)
 - a. Follow the procedure in the Lighting Instructions to manually light any standing pilots.
6. Electronic Spark-Ignited Pilot Ignition Check
 - a. Open pilot gas shut-off valves.
 - b. Turn up the Operating Pressure Control for a call for heat.
 - c. The electronic spark-ignited pilot(s) should ignite.
 - d. Turn down the Operating Pressure Control to stop the call for heat.
 - e. The spark-ignited pilot(s) should shut off.
7. Check Main Burner Ignition
 - a. With the Operating Pressure Control turned down, open the main gas shut-off valve(s).
 - b. Turn up the Operating Pressure Control for a call for heat.
 - c. The electronic spark-ignited pilot(s) should ignite.
 - d. The main gas valves will then open and the main burners should ignite.
 - e. Turn down the Operating Pressure Control to stop the call for heat.
 - f. The electronic spark-ignited pilot(s) and main burners should shut off.

E. CHECK MAIN BURNER SYSTEM

1. Remove the pressure test plug at the Main gas shut-off valve. Attach a U-tube manometer.
2. Restart the boiler by turning up the Operating Pressure Control for a call for heat.
3. Leak test all gas train joints with a soap suds solution.
4. Check the gas pressure at the entrance to the Gas Control train.
 - a. The pressure reading under flow should be between 5 and 14 inches water column (1.7 and 3.5 kPa).
 - b. If the pressure to the Gas Control Train exceeds 14 inches (3.5 kPa) under any conditions, the system must be provided with a lockup type gas pressure regulator to provide 14 inches (3.5 kPa) maximum.
5. Check the Manifold gas pressure.
 - a. Remove the 1/8" pipe plug from the manifold gas pressure tapping.
 - b. Attach a U-tube manometer.
 - c. Adjust the Main Gas Pressure Regulator to obtain 3.5 inches water column (.9 kPa) on Natural Gas 10 inches water column (2.5 kPa) on Propane (LP) Gas.
 - d. NOTE: If the pressure is adjusted to set the nameplate input to the boiler, do not set it more than 0.3 inches (75 Pa) plus or minus from the specified settings. If more adjustment to the rate is needed, it must be done by changing the burner gas orifices.

STARTING THE BOILER

- e. The Minimum input rate listed on the nameplate applies to boilers with staged firing rate. This minimum rate is not adjustable. It is controlled by an orifice in the gas train.
6. Check the burner input by reading the gas meter.
 - a. Each of the burners is rated at 105,000 Btu/hr (30.8 kW) for Natural Gas with a 0.60 specific gravity.
 - b. Each of the burners is rated at 102,500 Btu/hr (30 kW) for Propane (LP) Gas with a 1.56 specific gravity.
 - c. (U.S.) Determine the input by multiplying "F" – Meter Reading (Cubic Feet of Gas) times "H" – Heating Value of Gas (Btu per Cubic Foot) times 3600. Divide by "T" – the time in seconds at the meter reading.
$$\text{Rate, Btu/Hr} = \frac{F \times H \times 3600}{T}$$
(Metric) Determine the input by multiplying "F" – Meter Reading (Cubic Meters of Gas) times "H" – Heating Value of Gas (Joules per Cubic Meter). Divide by "T" – the time in seconds of the meter reading.
$$\text{Rate, Watts} = \frac{F \times H}{T}$$
 - d. Note: If the meter is not automatically corrected for temperature and pressure, the meter reading must be corrected to actual conditions during the rate test.
7. Adjustment of Primary Air
 - a. A bag of air adjustment screws is provided with the boiler, attached to one of the burners with pilot bracket.
 - b. Primary air adjustment is not normally required.
 - c. If primary air adjustment is needed, insert the self-tapping screws into the holes located on the top front of the burners.
 - d. Turn the screws in all the way until yellow flame tips appear. Turn the screws back out until the yellow tips disappear.

F. CHECK BOILER CONTROLS

1. Limit and Operating Pressure Controls
 - a. Lower the setting of each control until the burners shut down.
2. Low Water Cut-offs
 - a. Lower the water level in the boiler to below the control cut-off level. The burners should shut down.
3. Main Burner Shut-Off Valve(s)
 - a. Close Main Burner Shut-Off Valve(s).
 - b. The burners should shut down.
4. Check all controls to make sure they function correctly.
5. After all controls have been proven, set the Operating and Limit Pressure Controls to the pressures desired.

G. CLEAN THE BOILER

1. Clean the boiler as described below no later than one week after the initial start-up. Cleaning will be more effective if the boiler operates a day or two to loosen sediment and impurities in the system.
2. The boiler must be cleaned to remove any accumulation of oil, grease, sludge, etc. that may be

in the system. These substances can cause foaming and surging of the boiler water, producing an unstable water line and water carryover to the system.

WARNING

Cleaning the boiler requires the use of very hot water and corrosive chemicals. Use care when handling to prevent injury.

3. The piping for a skim valve must be done as shown in Section 5, "Pipe the Boiler," of this manual, with the skim valve mounted off of one of the end riser connections.
4. Connect a 2 inch drain line off of the skim valve, run to a point of safe discharge.
5. Close all valves to the system. Provide a means of continuous fresh water to the boiler for the cleaning process.
6. Use common washing soda (such as Arm and Hammer Super Washing Soda). Mix the soda with water in a 10 quart (9.5 liter) pail and pour into the boiler through the safety valve tapping. Use a proportion of one (1) pound (.5 kg) of washing soda for each 800 square feet (74 m²) EDR net boiler rating.
7. Open the skim valve. Fill the boiler until water begins to flow out the valve.

CAUTION

Do not leave the boiler unattended while firing.

Take great care not to allow the water level to drop below the bottom of the gauge glass or to allow fresh water make-up to flow in too fast. This will avoid the possibility of causing the boiler sections to fracture.

8. Turn burners on and allow the boiler water to heat up to just below steaming [180 to 200°F (82 to 93°C)]. Cycle the burners to maintain temperature during skimming. Do not allow the boiler to steam. Steaming mixes up the contaminants in the water instead of floating them at the surface.
9. Open the make-up water valve to continuously feed water to the boiler. Allow water to flow out of the skim tapping.
10. Continue skimming the boiler until the water flowing from the skim tapping flows clear. This will take some time, possibly several hours for a dirty system.
11. After skimming is complete, close the skim valve and turn off the boiler.
12. Close the make-up water valve and open the boiler blowdown valves.
13. Drain the boiler completely. Then refill and drain again one or two times to make sure all of the soda has been washed out.
14. Restore piping to normal. Pipe a nipple and cap in the skim valve.
15. Note: If the gauge glass becomes dirty again, this indicates more contaminants have worked loose in the system. Repeat the cleaning and skimming process as needed to clean the system.



11. OPERATING INSTRUCTIONS – TYPICAL

FOR YOUR SAFETY READ BEFORE LIGHTING

WARNING: If you do not follow these instructions exactly, a fire or explosion may result causing property damage, personal injury, or loss of life.

- A. This appliance is equipped with an ignition device which automatically lights the main pilots. Do not try to light the pilots by hand.
- B. BEFORE OPERATING smell all around the appliance area for gas. Be sure to smell next to the floor because some gas is heavier than air and will settle on the floor.
- WHAT TO DO IF YOU SMELL GAS
- Do not try to light any appliance
 - Do not touch any electric switch; do not use any phone in your building
 - Immediately call your gas supplier from a neighbor's phone. Follow the gas supplier's instructions.
- C. Use only your hand to push in or turn the gas control knob. Never use tools. If the knob will not push in or turn by hand, don't try to repair it, call a qualified service technician. Force or attempted repair may result in a fire or explosion.
- D. Do not use this appliance if any part has been under water. Immediately call a qualified service technician to inspect the appliance and to replace any part of the control system and any gas control which has been under water.
- If you cannot reach your gas supplier, call the fire department.

OPERATING INSTRUCTIONS

1. STOP! Read the safety information above on this label.
2. Set the thermostat or operating control to lowest setting.
3. Turn off all electric power to the appliance.
4. This appliance is equipped with an ignition device which automatically lights the pilot. Do not try to light the pilots by hand.
5. If the gas control assembly is not visible, remove control access panel.
6. If the manual shutoff lever(s) and pilot cock are not in the "OFF" position, turn both clockwise  to "OFF".
7. Wait five (5) minutes to clear out any gas, then smell for gas, including near the floor. If you smell gas STOP! Follow "B" in the safety information above on this label. If you don't smell gas, go to the next step.
8. Turn the pilot cock and the manual shutoff lever counterclockwise  to "ON".
9. Replace pilot access panel, if applicable.
10. Replace control access panel, if applicable.
11. Turn on all electric power to the appliance. Manually reset open limits and burner primary control. For boilers equipped with a Peerless Control Panel, place panel switches to "ON". Alarm may activate (if used). If so, switch alarm silencing switch.
12. Set thermostat or operating control to desired setting.
13. If the appliance will not operate, follow the instructions "To Turn Off Gas To Appliance" and call your service technician, or gas supplier.

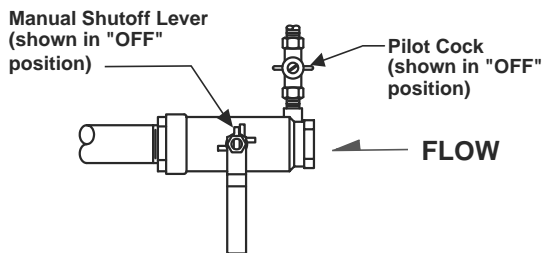

TO TURN OFF GAS TO APPLIANCE

1. Set the thermostat or operating control to lowest setting.
2. Turn off all electric power to the appliance if service is to be performed.
3. If the gas control assembly is not visible, remove the control access panel.
4. Turn the pilot cock and the manual shutoff lever clockwise  to "OFF".
5. Replace control access panel, if applicable.

V88A SPARK ONLY 9183R REV.2





Figure 11.1: Typical Operating Instructions - Spark Ignition Only (no Standing Pilots)

FOR YOUR SAFETY READ BEFORE LIGHTING

WARNING: If you do not follow these instructions exactly, a fire or explosion may result causing property damage, personal injury, or loss of life.

- A. This appliance is equipped with standing pilot(s) which must be lighted by hand, and may also be equipped with an ignition device which automatically lights intermittent pilot(s). Light only the standing pilot(s) by hand following these instructions exactly.
 - B. BEFORE OPERATING smell all around the appliance area for gas. Be sure to smell next to the floor because some gas is heavier than air and will settle on the floor.
- WHAT TO DO IF YOU SMELL GAS**
- Do not try to light any appliance
 - Do not touch any electric switch; do not use any phone in your building
 - Immediately call your gas supplier from a neighbor's phone. Follow the gas supplier's instructions.
 - If you cannot reach your gas supplier, call the fire department.
- C. Use only your hand to push in or turn the gas control knob. Never use tools. If the knob will not push in or turn by hand, don't try to repair it, call a qualified service technician. Force or attempted repair may result in a fire or explosion.
 - D. Do not use this appliance if any part has been under water. Immediately call a qualified service technician to inspect the appliance and to replace any part of the control system and any gas control which has been under water.

LIGHTING INSTRUCTIONS

1. STOP! Read the safety information above on this label.
 2. Set thermostat or operating control to lowest setting.
 3. Turn off all electric power to the appliance.
 4. If the gas control assembly is not visible, remove control access panel.
 5. If the manual shutoff lever(s) and pilot cock are not in the "OFF" position, turn both clockwise  to "OFF".
-
6. Wait five (5) minutes to clear out any gas. Then smell for gas, including near the floor. If you smell gas STOP! Follow "B" in the safety information above on this label. If you don't smell gas, go to the next step.
 7. Remove the pilot access panel, if supplied, located below and behind the gas valve directly above burner tubes.
 8. Find standing pilot(s) by following thermocouple from each thermopilot valve.
Note - Boiler may also be equipped with intermittent pilot(s) that are not to be lighted by hand.
 9. Turn the pilot cock handle counterclockwise  to "ON".
 10. Push in red reset button on right hand pilot all the way and hold in. Immediately light the right hand pilot with a match. Continue to hold the reset button in for about one (1) minute after the pilot is lit. Release button and it will pop back up. Pilot should remain lit. If it goes out, repeat steps 5 through 10.
 11. Repeat above lighting procedure for additional standing pilot(s).
 - If any button does not pop up when released, stop and immediately call your service technician or gas supplier.
 - If the pilots will not stay lit after several tries, turn the pilot cock handle to "OFF" and call your service technician or gas supplier.
 12. Replace pilot access panel, if applicable. 
 13. Turn manual shutoff lever counterclockwise  to "ON".
 14. Replace control access panel, if applicable.
 15. Turn on all electric power to the appliance. Manually reset open limits and burner primary control. For boilers equipped with a Peerless Control Panel, place all panel switches to "ON". Alarm may activate (if used). If so, switch alarm silencing switch.

TO TURN OFF GAS TO APPLIANCE

1. Set the thermostat or operating control to lowest setting.
2. Turn off all electric power to the appliance if service is to be performed.
3. If the gas control assembly is not visible, remove the control access panel.
4. Turn the gas pilot cock and manual shutoff lever clockwise  to "OFF".
5. Replace control access panel, if applicable.

9345 REV1

Figure 11.2: Typical Lighting and Operating Instructions - Models with Both Spark Ignited and Standing Pilots

12. OPERATION & MAINTENANCE

WARNING

Product Safety Information Refractory Ceramic Fiber Product

This appliance contains materials made from refractory ceramic fibers (RCF). Airborne RCF, when inhaled, have been classified by the International Agency for Research on Cancer (IARC), as a possible carcinogen to humans. After the RCF materials have been exposed to temperatures above 1800°F (982°C), they can change into crystalline silica, which has been classified by the IARC as carcinogenic to humans. If particles become airborne during service or repair, inhalation of these particles may be hazardous to your health.

Avoid Breathing Fiber Particulates and Dust

Suppliers of RCF recommend the following precautions be taken when handling these materials:

Precautionary Measures:

Provide adequate ventilation.

Wear a NIOSH/MSHA approved respirator.

Wear long sleeved, loose fitting clothing and gloves to prevent skin contact.

Wear eye goggles.

Minimize airborne dust prior to handling and removal by water misting the material and avoiding unnecessary disturbance of materials.

Wash work clothes separately from others. Rinse washer thoroughly after use.

Discard RCF materials by sealing in an airtight plastic bag.

First Aid Procedures:

Inhalation: If breathing difficulty or irritation occurs, move to a location with fresh clean air.

Seek immediate medical attention if symptoms persist.

Skin Contact: Wash affected area gently with a mild soap and warm water. Seek immediate medical attention if irritation persists.

Eye Contact: Flush eyes with water for 15 minutes while holding eyelids apart. Do not rub eyes.

Seek immediate medical attention if irritation persists.

Ingestion: Drink 1 to 2 glasses of water. Do not induce vomiting. Seek immediate medical attention.

⚠ WARNING

Do not store or allow combustible or flammable materials near the boiler. Substantial fire or explosion hazard could result, causing risk of personal injury, death or property damage.

Do not use this boiler if any part of it has been under water. Immediately call a qualified service technician to inspect the boiler. Any part of the control system, any gas control or any burner or gas component which has been under water must be replaced.

Should overheating occur or the fuel supply fail to shut off: Shut off the fuel supply at a location external to the boiler. Do not turn off or disconnect the electrical supply to the pump. Immediately call a qualified service technician to inspect the boiler for damage and defective components.

A. PLACING BOILER IN OPERATION

1. Start up the boiler per the Operating/Lighting Instructions shipped with the boiler.
2. Prove the correct operation of all controls on the boiler as outlined below.
3. Check the operation of the ignition and flame proving controls:
 - With the boiler operating, close the Pilot manual shutoff valve.
 - The ignition control should close the main gas valves within 1 second.
 - For HSP ignition systems, the control will spark and attempt to relight the pilot burner. After 90 seconds, the control will shut down and wait 5 to 6 minutes for another ignition trial.
 - For E*-E ignition systems, the RM7890 will need to be reset. Follow instructions provided with the control.
 - Open the Pilot manual shut-off valve and

re-start the boiler per the Lighting Instructions. (Standing pilots will have to be manually re-lit per the Lighting Instructions.)

4. Check the manifold gas pressure and use a soap suds mixture to check the gas tightness of all gas joints.
5. Test the limit and operating controls to assure they are operating correctly.
6. Inspect and test all low water cut-offs. (Float type controls must be flushed (blown down) weekly to remove any sediment from the float chamber.)
7. Test the pop safety relief valve(s) using the procedure given by the valve manufacturer on the valve tag.
8. Visually inspect the burner and pilot flames.
 - a. See Figure 12.1.
 - b. The flame inner cone should be about 1-1/2" (4 cm) high and should have a very sharp, blue color characteristic.
 - c. Poor flame conditions can be caused by dirty burners, obstructed orifices, or incorrect gas pressure.

B. TO SHUT DOWN THE BOILER

1. Open main line power disconnect switch to boiler.
2. Close Main and Pilot gas shut-off valves.
3. To take boiler out of service if the boiler and system are not to be used when temperatures are below freezing:
 - a. Drain the boiler and system completely and shut off make-up water supply.
 - b. Open main line power disconnect switch to boiler. Remove the fuses or secure the switch so that the power cannot be turned on accidentally.
 - c. Do not use ethylene glycol antifreeze in a steam boiler or system.

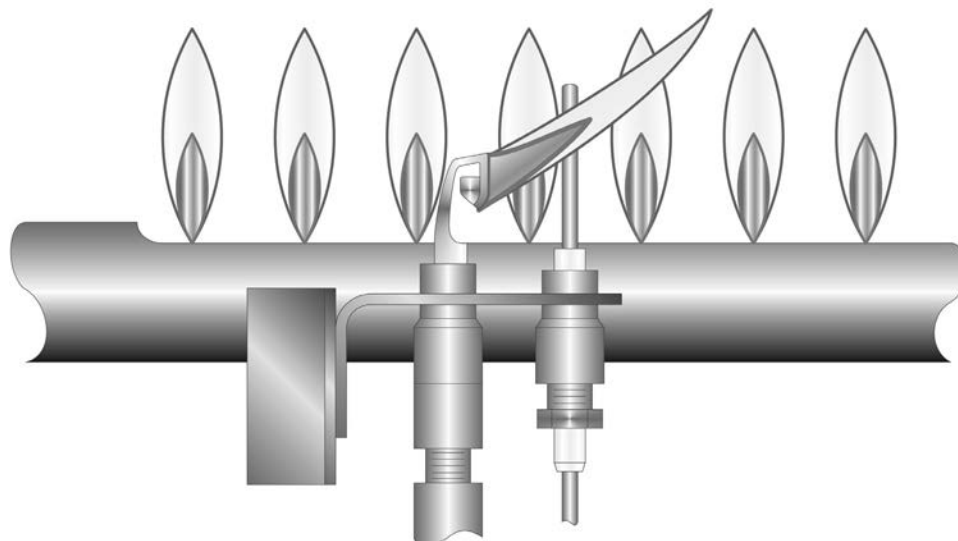

Figure 12.1: Pilot and Burner Flames

- d. Be certain that the boiler and system are refilled before returning to service. Follow the Instructions in this manual and the Lighting Instructions to operate.

C. ANNUAL MAINTENANCE

CAUTION

Before servicing the boiler:

- Turn off all electrical power to the boiler.
- Close the Gas Service Valve.
- Allow the boiler to cool if it has been operating.
- Label all wires prior to disconnection when servicing controls. Wiring errors can cause improper and dangerous operation. Verify proper operation after servicing.

1. **Before the start of each heating season**, inspect and make all necessary adjustments to insure proper boiler operation. Use the maintenance and inspection procedures following.
2. Inspect the Venting System
 - a. Check the chimney or vent to make sure it is clean and free from cracks or potential leaks.
 - b. All joints must be tight and sealed.
 - c. The vent connector must extend into, but not beyond, the inside edge of the chimney or vent.
3. Inspect the Boiler Area
 - a. The boiler area must be clean and free from combustible materials, gasoline or any other flammable liquids or vapors.
 - b. The combustion air openings and the area around the boiler must be unobstructed.
4. Inspect boiler flueways and burners for cleanliness. If cleaning is required, use the following procedure.
 - a. Turn off all electrical power to the boiler.
 - b. Remove top jacket panels, draft hood and flue collector.
 - c. Remove side cleanout panels.
 - d. Brush the boiler tube spaces both horizontally (through cleanout openings on ends) and vertically (from top of boiler).
 - e. Replace the flue collector, draft hood, jacket and cleanout panels using the procedures given in this manual.
 - f. Remove the burners and brush the gas ports lightly with a soft bristle brush.
5. Inspect the boiler base and insulation.
6. Inspect the boiler and piping for signs of leaks. Check to see if there are signs of heavy make-up water addition to the system.
7. When placing boiler into operation, follow Lighting Instructions shipped with the boiler and the instructions in this Chapter.
8. Test the operation of all limit controls, float controls, and ignition components as described in Part A, Placing Boiler in Operation, of this Chapter.

D. MONTHLY MAINTENANCE

1. Inspect the burner and pilot flames as for the annual inspection.
2. Inspect the boiler and system for any signs of leakage or excessive make-up water usage.
3. Inspect and check the operation of the venting system.

E. WEEKLY MAINTENANCE

1. Blow down the float type low water cut-offs and test for correct operation.

F. DAILY MAINTENANCE

1. Inspect the boiler area to make sure the area is free from combustible or flammable materials and that there are no obstructions to the flow of air to the boiler or combustion air openings to the room.
2. Make sure there are no signs of abnormal operation, such as overfilling or leakage.

CAUTION

Be very careful when adding water to a hot boiler. Add very slowly or, if possible, allow the boiler to cool naturally before adding water.

If an excessive loss of water occurs, check for a leak in the piping and correct the problem. Excessive make-up water will cause corrosion and damage to the boiler.

G. AUTOMATIC SAFETY SHUTOFF VALVE LEAKAGE TESTS

1. Installations subject to ASME CSD-1, Controls and Safety Devices for Automatically Fired Boilers, are required to perform leakage tests periodically on the automatic safety shutoff valves. CSD-1 recommends performing leakage tests annually.
2. Shut off electricity to boiler.
3. See Figure 12.2 for component locations referenced during these tests.
4. Disconnect wires at downstream automatic safety shutoff valve (A2). Isolate wires to prevent possible shock hazard.
5. Close both manual shutoff valves (M1, M2).
6. Test upstream automatic safety shutoff valve (A1).
 - a. Connect manometer or pressure gauge to inlet pilot tapping (P2) on downstream automatic safety shutoff valve.
 - b. Open upstream manual shutoff valve (M1).
 - c. If pressure rises with boiler de-energized, perform more detailed leakage test shown in Honeywell gas valve installation manual.
7. Test downstream automatic safety shutoff valve (A2).
 - a. Close both manual shutoff valves (M1, M2).
 - b. Connect manometer or pressure gauge to pilot tapping (P3) on downstream manual valve. If gas train includes pressure switches, plug will be in piping between manual valve (M2) and pressure switch.
 - c. Energize boiler, with power to downstream automatic shutoff valve (A2) still disconnected.
 - d. Verify that pilot(s) ignite and remain lit. Upstream shutoff valve (A1) must be energized during this test.
 - e. If pressure rises during this test, perform more detailed leakage test shown in Honeywell gas valve installation manual.

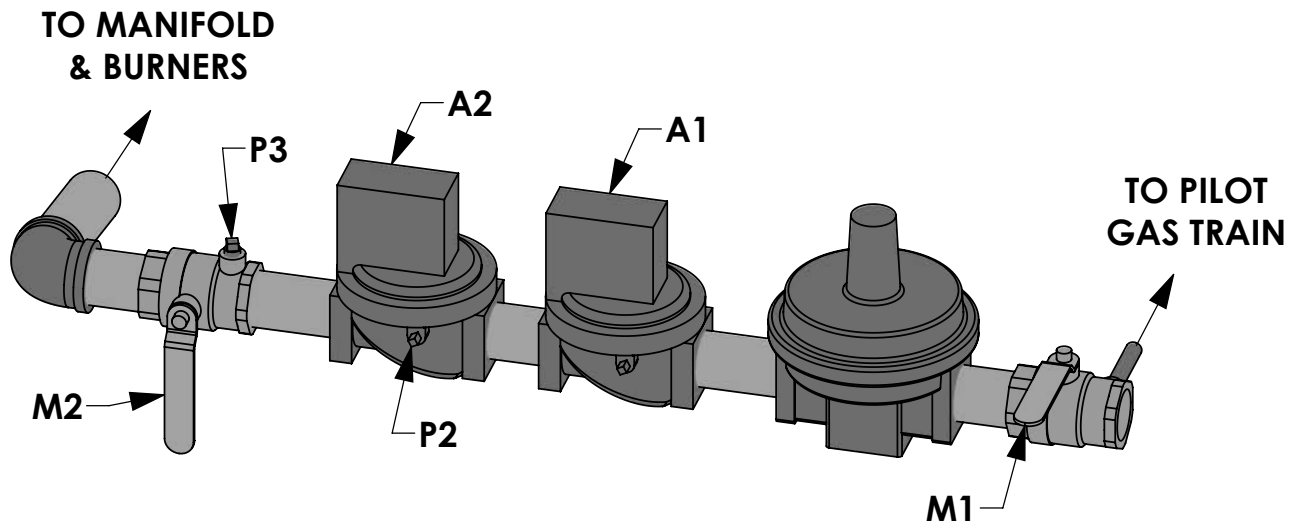

Figure 12.2: Automatic Safety Shutoff Valve Leakage Test



This Page Intentionally Left Blank

13. TROUBLESHOOTING – SERVICE TIPS

Problem	Possible Cause	Suggested Remedy
Pilot Outage (Units with Standing Pilots)	Defective Thermocouple	Replace
	Heavy Draft Blowing across Pilot	Redirect Air Movement or Eliminate
	Plugged Pilot Orifice	Replace Orifice
	No Gas	Check Manual Pilot Valve Check Main Gas Shut-Off Valve Check Manual Meter Valve Consult Gas Company
	Defective Thermopilot Valve	Replace
	Defective Ignition Control	Replace
Main Gas Valve Will Not Open	No Power	Check Power Source with Meter Check Fuses
	Defective Gas Valve	Replace
	RM7890A Locked Out on Safety (E*-E only)	Check for Pilot Outage
	Pilot Out (Units w/ Standing Pilots)	Relight Pilot (May have defective valve, relay or plugged orifice)
	Defective Relay	Replace
	Defective Thermocouple (Units w/ Standing Pilots)	Replace
	Low Water Level in Boiler or System Causing Low Water Cut-off to Function	Check for Leaks Check Feeder (if Supplied)
	Defective Thermopilot Valve (Units w/ Standing Pilots)	Replace
	Defective Ignition Control	Replace
	High Gas Pressure Switch Open (if Provided)	Check Switch Setting Check Manifold Gas Pressure
	Low Gas Pressure Switch Open (if Provided)	Check Switch Setting Check Manifold Gas Pressure
Burner(s) Burning with Yellow Flame	Air Adjustment Screws Turned in Too Far	Adjust Screws Out
	Low Gas Pressure in Manifold (Insufficient Air Injection)	Adjust Main Gas Pressure Regulator or Check Line Pressure
	Burner Ports Partially Closed (Rust, Dirt, Lint, etc.)	Replace Burners or Clean Ports
	Insufficient Air for Combustion	Check Size of Combustion Air Openings to Room, if Undersized, Correct as Required Check for Negative Pressure in Boiler Room
	Oversized Burner Orifice	Install Correct Orifice
	High Gas Pressure in Manifold	Adjust Main Gas Pressure Regulator
Gas Spillage from Draft Hood Relief Opening	Insufficient Draft – Chimney Too Low	Increase Height or Add Induced Draft Fan
	Insufficient Draft – Chimney Too Small	Replace Chimney or Add Induced Draft Fan
	Insufficient Draft – Blockage in Chimney or Vent	Repair Chimney or Vent
	Insufficient Draft – Downdraft Caused by Chimney Location with Respect to Other Buildings, Roofs, etc.	Install Chimney Cap
	Negative Pressure in Boiler Room (Due to Exhaust Fan or Duct System)	Remove Exhaust Fan or Isolate Fan From Boiler Room
	Insufficient Combustion Air Openings	Provide Correctly Sized Combustion and Ventilation Air Openings

Problem	Possible Cause	Suggested Remedy
Main Gas Valve Opens But No Gas Flows	Manual Valve Closed at Gas Train	Open Valve
	Manual Valve Closed at Meter	Open Valve
	Test Firing Valve Closed (if Provided)	Open Valve
Water Hammer On Start-Up	Sags in Steam Piping or not enough Pitch	Correct Piping Condition
	Concentric reducers causing condensate pooling	Correct Piping
	Drip trap failed closed	Replace Trap or Trap Element
	Dry returns wetted due to new boiler water line higher than old boiler	Correct Piping or Install Feed System and Traps
	No drip line on the back side of a back-pitched motorized valve	Install Drip Line and Trap
Water Hammer During Mid-Cycle	Clogged returns on gravity system	Clean or Re-Pipe Return Line(s)
	Incorrect near-boiler piping causing wet steam to system	Correct Piping per Manual
	Trap failed open, allowing steam to enter returns	Replace Trap or Trap Element
	{Radiator Hammer} Large radiator may be vented too quickly	Use smaller Air Vent or Use Two Small Vents in Place of One Large Vent, One Mounted Higher than the Other
	Long nipple at Hartford Loop	Replace with Close Nipple
	Water leg or back slope in return line to receiver tank, causing water pocketing	Correct Piping
	Trap installed at receiver tank, causing water trapping in return	Remove Trap at Tank, Installing Drip Traps and Radiator Traps where Required
	Boiler feed pump or condensate pump feed rate too fast, causing spraying into equalizer	Throttle Flow Rate
	No drip on the inlet side of a forward pitched motorized valve	Add Drip Line and Trap
	Uninsulated steam piping, causing excessive condensate loads	Insulate Steam Pipes
Water Hammer on Shut-Down	Close nipple on Hartford too high	Repipe 2" to 4" (5cm to 10cm) Below Water Line
	Uninsulated steam piping in boiler room, but system piping insulated, causing vacuum condition on shut-down	Insulate Steam Pipes
Hammering in the Boiler	Poor circulation in the boiler due to sludge accumulation	Clean and Blowdown the Boiler
No Heat or Poor Heat Distribution in the Building	Main vents not working	Replace Main Vents, Repiping away from End of Lines if Needed
	Drip Traps failed closed	Replace Traps or Trap Elements
	Radiator traps failed open, allowing pressurization of the returns	Replace Traps or Trap Elements
	Water legs or back slope in return lines to receiver tank, preventing air from venting out receiver vent	Correct Piping
	Boiler pressure too high, causing air vents to lock up or blowing water loop seals	Reduce Operating Pressure
System or Boiler Overfilling or Flooding	New boiler water content smaller than old boiler	Install Boiler Feed System with Receiver Tank Large enough for Condensate
	Boiler water feed rate or pump rate too fast causing water level to collapse (due to collapse of steam bubbles in boiler water)	Reduce Feed Rate
	Foaming, priming or surging due to poor water quality	Clean the Boiler
Excessive Water Level Bounce	Poor water quality, causing foaming and surging	Clean the Boiler
	Incorrect near-boiler piping, such as undersized or incorrectly placed risers	Pipe per Manual
	Boiler water feed rate or pump rate too fast	Reduce Feed Rate
Rapid Cycling	Air vents or traps not venting air, preventing steam from getting to radiation and pressurizing the air pocket	Replace Vents or Traps
	Pressure differential on pressure control too close	Adjust Control Differential
	Nuisance outages of water level control due to boiler water level bounce	See Excessive Water Level Bounce Above

14. BOILER RATINGS & DIMENSIONS

Table 14.1: Boiler Rating Information

Boiler Model Number	Natural Gas Ratings												LP Gas (2500 Btu/cu. ft.; 93,000 kJ/m ³)												Efficiency	
	Input						Output						Net Ratings						Net Ratings						Thml %	Cmb %
	MBH		kW		Sg. Ft.		MBH		kW		Sg. Ft.		Steam EDR		Steam EDR		M BH		kW		Boiler H.P.	Steam Piping Factor				
	MBH	kW	MBH	kW	Sg. Ft.	Sg. Ft.	MBH	kW	MBH	kW	Sg. Ft.	Sg. Ft.	MBH	kW	MBH	kW	M BH	kW	M BH	kW						
211A-04	630	185	486	142	1,521	141	365	107	1,333	14.5	615	180	474	139	1,483	138	356	104	1,333	14.2	77.1	79.8				
211A-05	840	246	650	190	2,033	189	488	143	1,333	19.4	820	240	635	186	1,983	184	476	140	1,333	19.0	77.4	80.0				
211A-06	1,050	308	816	239	2,550	237	612	179	1,333	24.4	1,025	300	796	233	2,488	231	597	175	1,333	23.8	77.7	80.0				
211A-07	1,260	369	980	287	3,063	285	735	215	1,333	29.3	1,230	360	957	280	2,992	278	718	210	1,333	28.6	77.8	80.0				
211A-08	1,470	431	1,145	336	3,579	332	859	252	1,333	34.2	1,435	421	1,118	328	3,496	325	839	246	1,333	33.4	77.9	80.0				
211A-09	1,680	492	1,310	384	4,113	382	987	289	1,333	39.1	1,640	481	1,279	375	4,008	372	962	282	1,330	38.2	78.0	80.0				
211A-10	1,890	554	1,476	433	4,688	436	1,125	330	1,312	44.1	1,845	541	1,441	422	4,567	424	1,096	321	1,315	43.0	78.1	80.0				
211A-11	2,100	615	1,642	481	5,263	489	1,263	370	1,300	49.1	2,050	601	1,603	470	5,125	476	1,230	360	1,303	47.9	78.2	80.0				
211A-12	2,310	677	1,806	529	5,829	542	1,399	410	1,291	54.0	2,255	661	1,763	517	5,679	528	1,363	399	1,293	52.7	78.2	80.0				
211A-13	2,520	739	1,958	574	6,333	588	1,520	445	1,288	58.5	2,460	721	1,911	560	6,179	574	1,483	435	1,289	57.1	77.7	80.0				
211A-14	2,730	800	2,124	622	6,871	638	1,649	483	1,288	63.5	2,665	781	2,073	608	6,704	623	1,609	472	1,288	61.9	77.8	80.0				
211A-15	2,940	862	2,290	671	7,408	688	1,778	521	1,288	68.4	2,870	841	2,236	655	7,233	672	1,736	509	1,288	66.8	77.9	80.0				
211A-16	3,150	923	2,454	719	7,938	737	1,905	558	1,288	73.3	3,075	901	2,395	702	7,746	720	1,859	545	1,288	71.5	77.9	80.0				
211A-17	3,360	985	2,621	768	8,479	788	2,035	596	1,288	78.3	3,280	961	2,558	750	8,275	769	1,986	582	1,288	76.4	78.0	80.0				
211A-18	3,570	1,046	2,785	816	9,008	837	2,162	634	1,288	83.2	3,485	1,021	2,718	797	8,792	817	2,110	618	1,288	81.2	78.0	80.0				
211A-19	3,780	1,108	2,952	865	9,550	887	2,292	672	1,288	88.2	3,690	1,081	2,882	845	9,325	866	2,238	656	1,288	86.1	78.1	80.0				
211A-20	3,990	1,169	3,116	913	10,079	936	2,419	709	1,288	93.1	3,895	1,142	3,042	892	9,842	914	2,362	692	1,288	90.9	78.1	80.0				
211A-21	4,200	1,231	3,280	961	10,613	986	2,547	746	1,288	98.0	4,100	1,202	3,202	938	10,358	962	2,486	729	1,288	95.7	78.1	80.0				
211A-22	4,410	1,292	3,449	1,011	11,158	1,037	2,678	785	1,288	103.0	4,305	1,262	3,367	987	10,892	1,012	2,614	766	1,288	100.6	78.2	80.0				
211A-23	4,620	1,354	3,599	1,055	11,642	1,082	2,794	819	1,288	107.5	4,510	1,322	3,513	1,030	11,363	1,056	2,727	799	1,288	104.9	77.9	80.0				
211A-24	4,830	1,416	3,763	1,103	12,175	1,131	2,922	856	1,288	112.4	4,715	1,382	3,673	1,076	11,883	1,104	2,852	836	1,288	109.7	77.9	80.0				
211A-25	5,040	1,477	3,931	1,152	12,717	1,181	3,052	894	1,288	117.4	4,920	1,442	3,838	1,125	12,417	1,154	2,980	873	1,288	114.7	78.0	80.0				
211A-26	5,250	1,539	4,095	1,200	13,246	1,231	3,179	932	1,288	122.3	5,125	1,502	3,998	1,172	12,933	1,202	3,104	910	1,288	119.4	78.0	80.0				
211A-27	5,460	1,600	4,259	1,248	13,779	1,280	3,307	969	1,288	127.2	5,330	1,562	4,157	1,218	13,446	1,249	3,227	946	1,288	124.2	78.0	80.0				
211A-28	5,670	1,662	4,428	1,298	14,325	1,331	3,438	1,008	1,288	132.3	5,535	1,622	4,323	1,267	13,983	1,299	3,356	984	1,288	129.1	78.1	80.0				
211A-29	5,880	1,723	4,592	1,346	14,854	1,380	3,565	1,045	1,288	137.2	5,740	1,682	4,483	1,314	14,504	1,347	3,481	1,020	1,288	133.9	78.1	80.0				
211A-30	6,090	1,785	4,756	1,394	15,388	1,430	3,693	1,082	1,288	142.1	5,945	1,742	4,643	1,361	15,021	1,395	3,605	1,057	1,288	138.7	78.1	80.0				
211A-31	6,300	1,846	4,920	1,442	15,917	1,479	3,820	1,120	1,288	147.0	6,150	1,802	4,803	1,408	15,538	1,444	3,729	1,093	1,288	143.5	78.1	80.0				
211A-32	6,510	1,908	5,084	1,490	16,446	1,528	3,947	1,157	1,288	151.9	6,355	1,862	4,963	1,455	16,054	1,491	3,853	1,129	1,288	148.3	78.1	80.0				
211A-33	6,720	1,969	5,255	1,540	17,000	1,579	4,080	1,196	1,288	157.0	6,560	1,923	5,130	1,503	16,596	1,542	3,983	1,167	1,288	153.2	78.2	80.0				
211A-34	6,930	2,031	5,419	1,588	17,529	1,628	4,207	1,233	1,288	161.9	6,765	1,983	5,290	1,550	17,113	1,590	4,107	1,204	1,288	158.0	78.2	80.0				
211A-35	7,140	2,093	5,583	1,636	18,063	1,678	4,335	1,270	1,288	166.8	6,970	2,043	5,451	1,598	17,633	1,638	4,232	1,240	1,288	162.8	78.2	80.0				
211A-36	7,350	2,154	5,748	1,685	18,596	1,728	4,463	1,308	1,288	171.7	7,175	2,103	5,611	1,644	18,150	1,686	4,356	1,277	1,288	167.6	78.2	80.0				
211A-37	7,560	2,216	5,904	1,730	19,100	1,774	4,584	1,343	1,288	176.4	7,380	2,163	5,764	1,689	18,646	1,732	4,475	1,311	1,288	172.2	78.1	80.0				
211A-38	7,770	2,277	6,068	1,778	19,629	1,824	4,711	1,381	1,288	181.3	7,580	2,216	5,915	1,730	19,150	1,774	4,598	1,349	1,288	177.8	78.1	80.0				
211A-39	7,980	2,339	6,232	1,826	20,163	1,873	4,839	1,418	1,288	186.2	7,780	2,277	6,068	1,778	19,629	1,824	4,711	1,381	1,288	181.3	78.1	80.0				
211A-40	8,190	2,400	6,396	1,874	20,692	1,922	4,966	1,455	1,288	191.1	7,980	2,339	6,232	1,826	20,163	1,873	4,839	1,418	1,288	186.2	78.1	80.0				
211A-41	8,400	2,462	6,560	1,923	21,221	1,971	5,093	1,493	1,288	196.0	8,180	2,400	6,396	1,874	20,692	1,922	4,966	1,455	1,288	191.1	78.1	80.0				
211A-42	8,610	2,523	6,724	1,971	21,750	2,021	5,220	1,530	1,288	200.9	8,380	2,462	6,560	1,923	21,221	1,971	5,093	1,493	1,288	196.0	78.1	80.0				
211A-43	8,820	2,585	6,888	2,019	22,283	2,070	5,348	1,567	1,288	205.8	8,580	2,523	6,888	1,971	21,750	2,021	5,220	1,530	1,288	200.9	78.1	80.0				
211A-44	9,030	2,646	7,061	2,069	22,842	2,122	5,482	1,607	1,288	210.9	8,780	2,585	7,061	2,069	22,842	2,122	5,482	1,607	1,288	210.9	78.1	80.0				
211A-45	9,240	2,708	7,226	2,118	23,375	2,172	5,610	1,644	1,288	215.9	8,980	2,646	7,226	2,118	23,375	2,172	5,610	1,644	1,288	215.9	78.2	80.0				
211A-46	9,450	2,770	7,390	2,166	23,908	2,221	5,738	1,682	1,288	220.8	9,180	2,708	7,390	2,166	23,908	2,221	5,738	1,682	1,288	220.8	78.2	80.0				

BOILER MODEL NUMBERS 211A-38 TO 211A-46 ARE CERTIFIED FOR NATURAL GAS ONLY. CONTACT THE FACTORY.

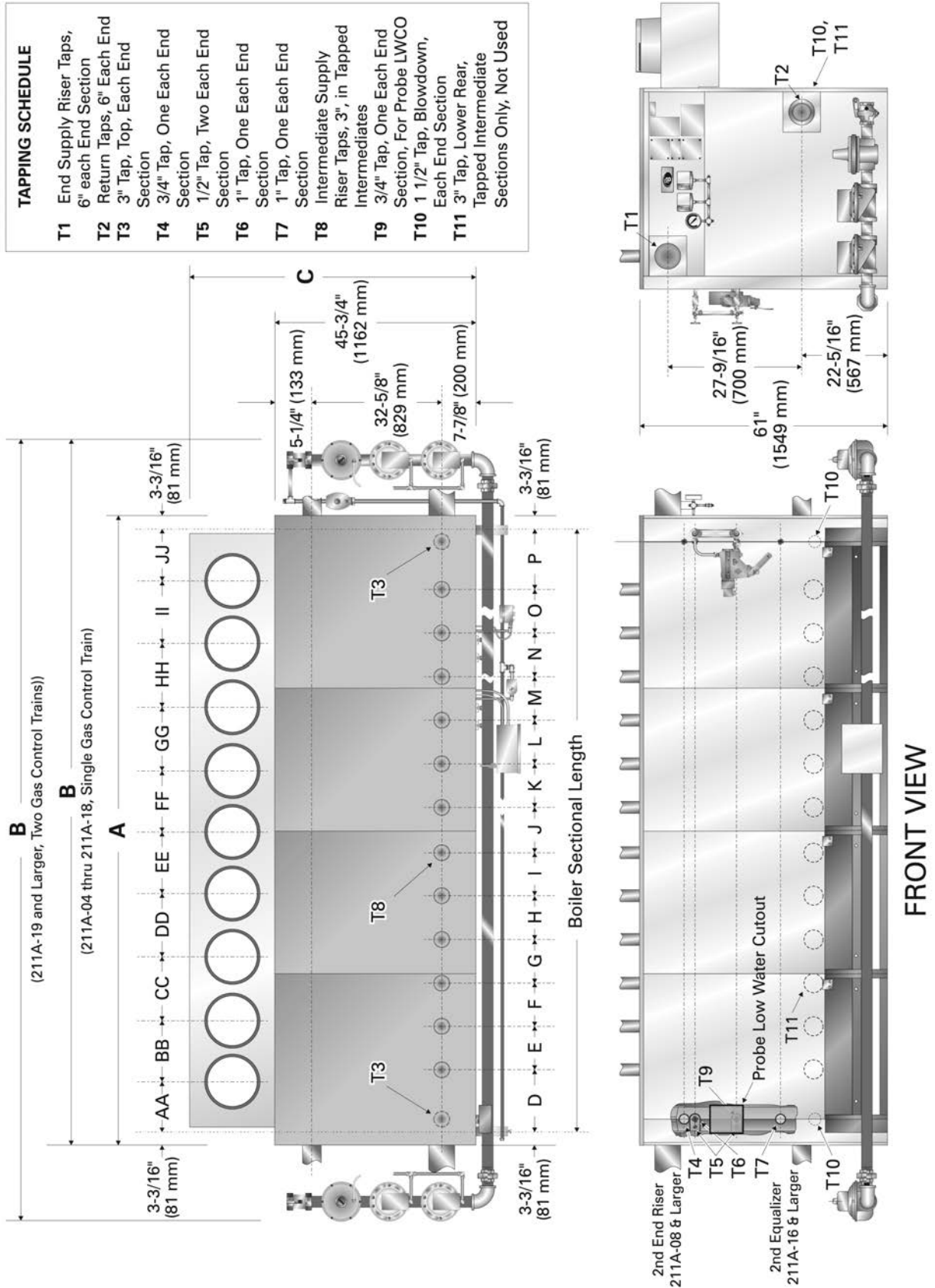

Figure 14.1: Boiler Dimensions

BOILER RATINGS & DIMENSIONS

Boiler Model No.	Length & Width Dimensions						Boiler Section Length		Intermediate Supply/Return Locations (Dimensions are approximate)																											
	A		B		C		inch	mm	No.	Size	D		E		F		G		H		I		J		K		L		M		N		O		P	
	inch	mm	inch	mm	inch	mm					inch	mm	inch	mm	inch	mm	inch	mm	inch	mm	inch	mm	inch	mm	inch	mm	inch	mm	inch	mm	inch	mm	inch	mm	inch	mm
211A-04	28 3/4	714	38 3/4	975	63	160	21 3/4	552																												
211A-05	33 3/4	857	44	1,118	63	160	27 3/4	695																												
211A-06	39 3/4	1,000	50 3/4	1,276	65	165	33	838																												
211A-07	45	1,143	55 3/4	1,419	63	160	38 3/4	981																												
211A-08	50 3/4	1,286	61 3/4	1,568	63	160	44 1/4	1,124																												
211A-09	56 1/4	1,429	67 3/4	1,718	63	160	49 3/4	1,267																												
211A-10	61 1/2	1,572	73 3/4	1,861	65	165	55 1/2	1,410																												
211A-11	67 1/2	1,715	80 3/4	2,051	65	165	61 1/2	1,553																												
211A-12	73 1/4	1,857	86 3/4	2,194	63	160	66 3/4	1,695																												
211A-13	78 3/4	2,000	91 3/4	2,324	63	160	72 3/4	1,838																												
211A-14	84 3/4	2,143	97 3/4	2,467	65	165	78	1,981																												
211A-15	90	2,286	102 3/4	2,610	65	165	83 3/4	2,124																												
211A-16	95 3/4	2,429	108 3/4	2,753	65	165	89 3/4	2,267																												
211A-17	101 1/4	2,572	114 3/4	2,902	65	165	94 3/4	2,410																												
211A-18	106 3/4	2,715	120 3/4	3,058	65	165	100 1/4	2,553																												
211A-19	112 3/4	2,858	126 3/4	3,214	65	165	106 1/4	2,696																												
211A-20	118 3/4	3,001	132 3/4	3,367	65	165	111 3/4	2,838																												
211A-21	123 3/4	3,144	138 3/4	3,520	65	165	117 3/4	2,981																												
211A-22	129 3/4	3,286	144 3/4	3,673	65	165	123 3/4	3,124																												
211A-23	135	3,429	150 3/4	3,826	65	165	128 3/4	3,267																												
211A-24	140 3/4	3,572	156 3/4	4,010	65	165	134 1/4	3,410																												
211A-25	146 1/4	3,715	172	4,369	65	165	139 3/4	3,553																												
211A-26	151 1/2	3,858	177 3/4	4,512	65	165	145 1/2	3,696																												
211A-27	157 1/2	4,001	183 3/4	4,655	65	165	151 1/2	3,839																												
211A-28	163 3/4	4,143	188 3/4	4,797	65	165	156 3/4	3,981																												
211A-29	168 3/4	4,286	194 3/4	4,940	65	165	162 3/4	4,124																												
211A-30	174 3/4	4,429	200 3/4	5,083	65	165	168	4,267																												
211A-31	180	4,572	205 3/4	5,226	65	165	173 3/4	4,410																												
211A-32	185 3/4	4,715	211 3/4	5,369	65	165	179 3/4	4,553																												
211A-33	191 1/4	4,858	217 1/2	5,512	65	165	184 3/4	4,696																												
211A-34	196 3/4	5,001	223 3/4	5,655	65	165	190 3/4	4,839																												
211A-35	202 3/4	5,144	229 3/4	5,829	65	165	196 3/4	4,982																												
211A-36	208 3/4	5,286	235 3/4	6,010	65	165	201 3/4	5,124																												
211A-37	213 3/4	5,429	241 3/4	6,153	65	165	207 3/4	5,267																												
211A-38	219 3/4	5,572	247 3/4	6,300	65	165	213 3/4	5,410																												
211A-39	225	5,715	253 3/4	6,443	65	165	218 3/4	5,553																												
211A-40	230 3/4	5,858	259 3/4	6,586	65	165	224 3/4	5,696																												
211A-41	236 1/4	6,001	265 3/4	6,729	65	165	229 3/4	5,839																												
211A-42	241 3/4	6,144	271 3/4	6,872	65	165	235 3/4	5,982																												
211A-43	247 3/4	6,286	277 3/4	7,015	65	165	241 3/4	6,125																												
211A-44	253 3/4	6,429	283 3/4	7,158	65	165	246 3/4	6,267																												
211A-45	258 3/4	6,572	289 3/4	7,301	65	165	252 3/4	6,410																												
211A-46	264 3/4	6,715	295 3/4	7,444	65	165	258	6,553																												

Chart continues on page 51.

Boiler Model No.	Flue Connection Center Lines												Flue Connections			Vent Connector		Chimney Diameter x 20ft (6m) high											
	AA		BB		CC		DD		EE		FF		GG		HH		II		JJ		No.		Size		Diameter		Diameter		
	inch	mm	inch	mm	inch	mm	inch	mm	inch	mm	inch	mm	inch	mm	inch	mm	inch	mm	inch	mm	inch	mm	inch	mm	inch	mm	inch	mm	inch
211A-04	10 3/4	276																			1	12	305	12	305	12	305	12	305
211A-05	13 3/4	349																			1	12	305	12	305	12	305	12	305
211A-06	16 1/2	419																			1	14	356	14	356	14	356	14	356
211A-07	10 3/4	276	16 1/2	429																	2	12	305	14	356	14	356	14	356
211A-08	13 3/4	349	19 3/8	498																	2	12	305	15	381	15	381	15	381
211A-09	13 3/4	349	22 1/2	572																	2	12	305	16	406	16	406	16	406
211A-10	16 1/2	419	25 3/8	645																	2	14	356	17	432	17	432	17	432
211A-11	16 1/2	419	28 3/8	714																	2	14	356	18	457	18	457	18	457
211A-12	13 3/4	349	22 1/2	572	19 3/8	498															3	12	305	18	457	18	457	18	457
211A-13	13 3/4	349	22 1/2	572	22 1/2	572															3	12	305	19	483	19	483	19	483
211A-14	16 1/2	419	25 3/8	645	22 1/2	572															3	14	356	20	508	20	508	20	508
211A-15	16 1/2	419	25 3/8	645	25 3/8	641															3	14	356	21	533	21	533	21	533
211A-16	16 1/2	419	28 3/8	714	28 3/8	714															3	14	356	21	533	21	533	21	533
211A-17	13 3/4	349	22 1/2	572	22 1/2	572	22 1/2	572													4	14	356	22	559	22	559	22	559
211A-18	16 1/2	419	25 3/8	645	22 1/2	572	22 1/2	572													4	14	356	23	584	23	584	23	584
211A-19	13 3/4	349	25 3/8	645	28 3/8	714	25 3/8	641													4	14	356	23	584	23	584	23	584
211A-20	16 1/2	419	28 3/8	714	28 3/8	714	25 3/8	645													4	14	356	24	610	24	610	24	610
211A-21	16 1/2	419	28 3/8	714	28 3/8	714	28 3/8	714													4	14	356	25	635	25	635	25	635
211A-22	16 1/2	419	25 3/8	645	22 1/2	572	22 1/2	572	22 1/2	572											5	14	356	25	635	25	635	25	635
211A-23	16 1/2	419	28 3/8	714	25 3/8	645	22 1/2	572	22 1/2	572											5	14	356	26	660	26	660	26	660
211A-24	16 1/2	419	28 3/8	714	28 3/8	714	25 3/8	645	22 1/2	572											5	14	356	26	660	26	660	26	660
211A-25	16 1/2	419	28 3/8	714	28 3/8	714	28 3/8	714	25 3/8	645											5	14	356	27	686	27	686	27	686
211A-26	16 1/2	419	28 3/8	714	28 3/8	714	28 3/8	714	28 3/8	714											5	14	356	27	686	27	686	27	686
211A-27	16 1/2	419	28 3/8	714	25 3/8	645	22 1/2	572	22 1/2	572	22 1/2	572									6	14	356	28	711	28	711	28	711
211A-28	16 1/2	419	28 3/8	714	28 3/8	714	25 3/8	645	22 1/2	572	22 1/2	572									6	14	356	29	737	29	737	29	737
211A-29	16 1/2	419	28 3/8	714	28 3/8	714	28 3/8	714	25 3/8	645	22 1/2	572									6	14	356	29	737	29	737	29	737
211A-30	16 1/2	419	28 3/8	714	28 3/8	714	28 3/8	714	28 3/8	714	25 3/8	645									6	14	356	30	762	30	762	30	762
211A-31	16 1/2	419	28 3/8	714	28 3/8	714	28 3/8	714	28 3/8	714	28 3/8	714									6	14	356	30	762	30	762	30	762
211A-32	16 1/2	419	28 3/8	714	28 3/8	714	25 3/8	645	22 1/2	572	22 1/2	572	22 1/2	572							7	14	356	31	787	31	787	31	787
211A-33	16 1/2	419	28 3/8	714	28 3/8	714	28 3/8	714	25 3/8	645	22 1/2	572	22 1/2	572							7	14	356	31	787	31	787	31	787
211A-34	16 1/2	419	28 3/8	714	28 3/8	714	28 3/8	714	28 3/8	714	25 3/8	645	22 1/2	572							7	14	356	32	813	32	813	32	813
211A-35	16 1/2	419	28 3/8	714	28 3/8	714	28 3/8	714	28 3/8	714	28 3/8	714	25 3/8	645							7	14	356	32	813	32	813	32	813
211A-36	16 1/2	419	28 3/8	714	28 3/8	714	28 3/8	714	28 3/8	714	28 3/8	714	28 3/8	714							7	14	356	33	838	33	838	33	838
211A-37	16 1/2	419	28 3/8	714	28 3/8	714	28 3/8	714	25 3/8	645	22 1/2	572	22 1/2	572	22 1/2	572					8	14	356	33	838	33	838	33	838
211A-38	13 3/4	349	22 1/2	572	22 1/2	572	25 3/8	641	28 3/8	714	28 3/8	714	28 3/8	714	28 3/8	714					8	14	356	34	864	34	864	34	864
211A-39	13 3/4	349	22 1/2	572	25 3/8	641	28 3/8	714	28 3/8	714	28 3/8	714	28 3/8	714	28 3/8	714					8	14	356	34	864	34	864	34	864
211A-40	13 3/4	349	25 3/4	641	28 3/8	714	28 3/8	714	28 3/8	714	28 3/8	714	28 3/8	714	28 3/8	714					8	14	356	35	889	35	889	35	889
211A-41	16 1/2	419	28 3/8	714	28 3/8	714	28 3/8	714	28 3/8	714	28 3/8	714	28 3/8	714	28 3/8	714					8	14	356	35	889	35	889	35	889
211A-42	13 3/4	349	22 1/2	572	22 1/2	572	22 1/2	572	25 3/8	641	28 3/8	714	28 3/8	714	28 3/8	714	28 3/8	714			9	14	356	36	914	36	914	36	914
211A-43	13 3/4	349	22 1/2	572	22 1/2	572	25 3/8	641	28 3/8	714	28 3/8	714	28 3/8	714	28 3/8	714	28 3/8	714			9	14	356	36	914	36	914	36	914
211A-44	13 3/4	349	22 1/2	572	25 3/8	641	28 3/8	714	28 3/8	714	28 3/8	714	28 3/8	714	28 3/8	714	28 3/8	714			9	14	356	36	914	36	914	36	914
211A-45	13 3/4	349	25 3/4	641	28 3/8	714	28 3/8	714	28 3/8	714	28 3/8	714	28 3/8	714	28 3/8	714	28 3/8	714			9	14	356	37	940	37	940	37	940
211A-46	16 1/2	419	28 3/8	714	28 3/8	714	28 3/8	714	28 3/8	714	28 3/8	714	28 3/8	714	28 3/8	714	28 3/8	714			9	14	356	37	940	37	940	37	940

15. REPAIR PARTS – SERIES 211A™

Repair parts are available from your local PB Heat, LLC distributor or from Parts To Your Door at 1 (610) 916-5380 (www.partstoyourdoor.com).

Note: Remember to include the boiler model number and serial number when ordering parts.

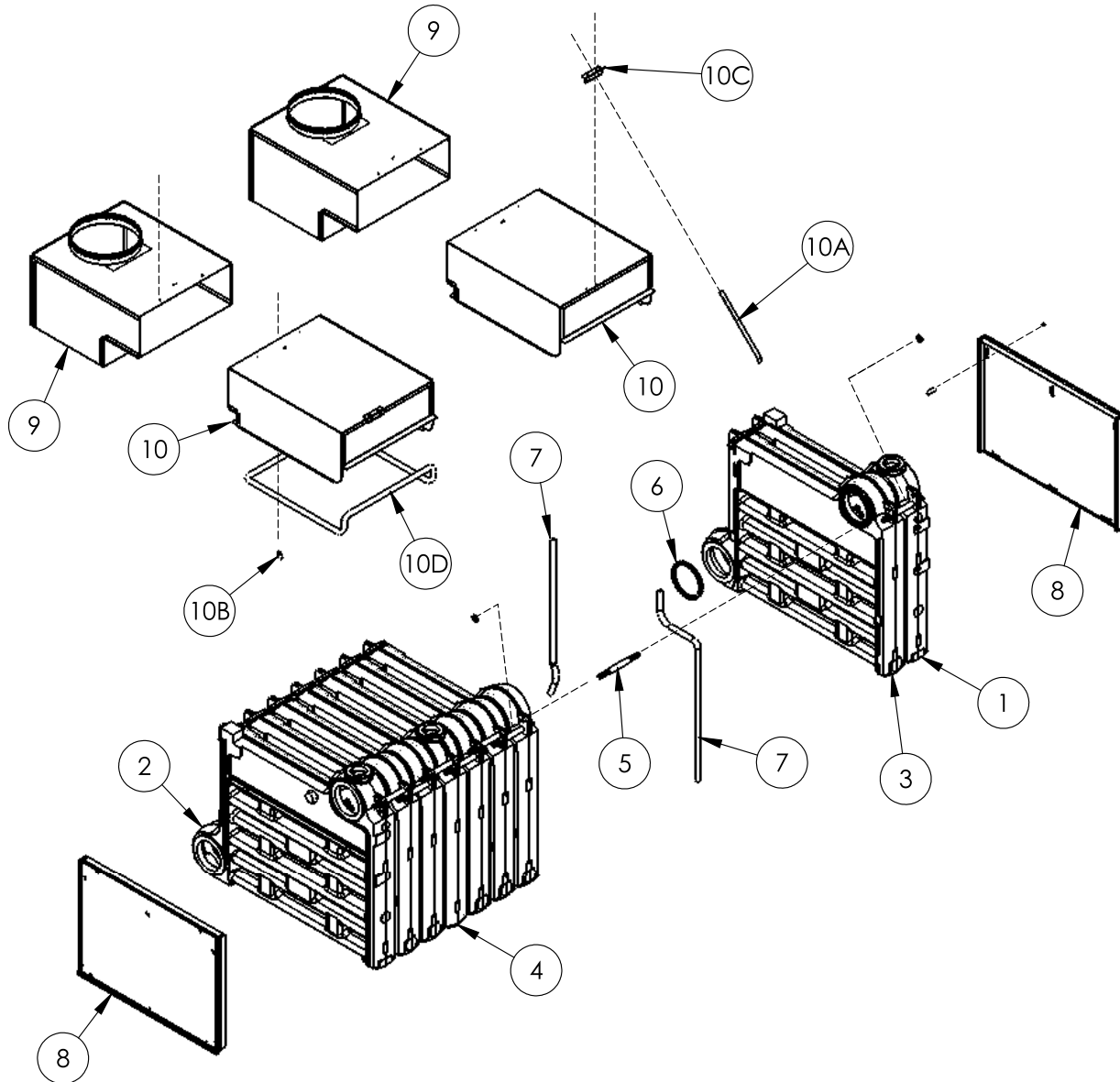

Figure 15.1: Block/Flue Collector/Draft Hood Repair Parts

Table 15.1: Block/Flue Collector/Draft Hood Repair Parts

	Description	Quantity Required	Stock Code
1	Right Hand End Section (50 psi) – GG1024	–	90059
	Right Hand End Section (80 psi) – GG1024-1	–	90060
2	Left Hand End Section (50 psi) – GG1023	–	90625
	Left Hand End Section (80 psi) – GG1023-1	–	90626
3	Plain Intermediate Section (50 psi) – GG1000	–	90356
	Plain Intermediate Section (80 psi) – GG1000-1	–	90357
4	Tapped Intermediate Section (50 psi) – GG1025	–	90065
	Tapped Intermediate Section (80 psi) – GG1025-1	–	90066
Not Shown	Plain Intermediate Section w/ Inspection Tapping (50 psi) – GG1000-2	–	90358
	Plain Intermediate Section w/ Inspection Tapping (80 psi) – GG1000-3	–	90359
5	Tie Rod	2 per Flueway	90090
6	Flow Port Gasket	2 per Flueway	51670
7	High Temperature Rope, Diameter 5/8" (16 mm) – 6-1/2' Length per Flueway	–	55723
8	Cleanout Cover Plate with Insulation (set of 2)	1	90489
9	Draft Hood – Box 13 with 12" Dia. Outlet (For Flue Collector 5000) ¹	–	90399
	Draft Hood – Box 13A with 12" Dia. Outlet (For Flue Collector 5000-1) ¹	–	90400
	Draft Hood – Box 13B with 14" Dia. Outlet (For Flue Collector 5000-1) ¹	–	90401
	Draft Hood – Box 13A with 14" Dia. Outlet (For Flue Collector 5000-2) ¹	–	90402
10	Flue Collector – Box 14 – GG-5000 (Includes 10A, 10B, 10C, 10D) ²	–	90557
	Flue Collector – Box 14A – GG-5000-1 (Includes 10A, 10B, 10C, 10D) ²	–	90558
	Flue Collector – Box 14B – GG-5000-2 (Includes 10A, 10B, 10C, 10D) ²	–	90559
10A	Front Flue Collector Hook Bolt (1 per Flue Collector)	1	GG5003
10B	Rear Flue Collector Hook Bolt (1 per Flue Collector)	1	GG5004
10C	Flue Collector Mounting Bracket (1 per Flue Collector)	1	GG5005
10D	High Temperature Rope, Diameter 5/8" (16 mm)- 10' Length per Flue Collector	–	55723

1 See IOM Instructions Table 6.2 for Draft Hood Location Layout

2 See IOM Instructions Table 4.1 for Flue Collector Location Layout

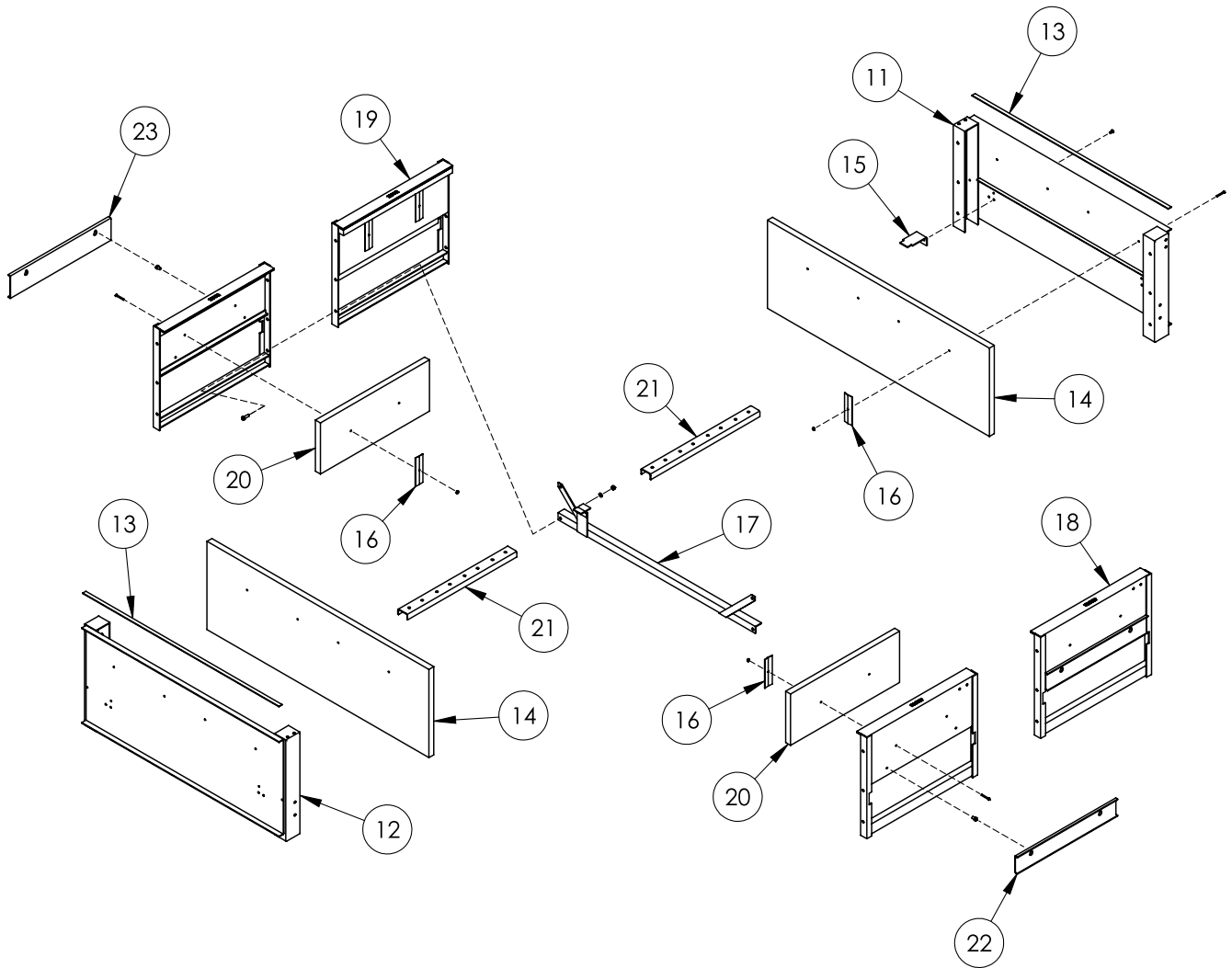

Figure 15.2: Base Assembly Repair Parts

Table 15.2: Base Assembly Repair Parts

	Description	Quantity Required	Stock Code
11	Base Right End Panel w/ Insulation (Includes Item #13, #14, #15 & #16)	–	90737
12	Base Left End Panel w/ Insulation (Includes Item #13, #14, #15 & #16)	–	90738
13	Ceramic Knitted Tape- 1/16 x 1" x 40"	–	99
14	Base End Panel Insulation Kit (Includes 2 insulation pieces, #14, #16 & hardware)	–	90333
15	Burner Support Clip	–	90590
16	Insulation Fastener	–	GG2104
17	Angle Tie Brace Assembly	–	90326
18	Base Front Panel Assembly (includes #16, #20 & #22) – 16-7/8" Wide Module 211A-04 ³	–	90932
	Base Front Panel Assembly (includes #16, #20 & #22) – 22-1/2" Wide Module 211A-05 ³	–	91800
	Base Front Panel Assembly (includes #16, #20 & #22) – 28-1/8" Wide Module 211A-06 ³	–	91801
	Base Front Panel Assembly (includes #16, #20 & #22) – 33-3/4" Wide Module 211A-07 ³	–	91802
	Base Front Panel Assembly includes #16, #20 & #22) – 39-3/8" Wide Module 211A-08 ³	–	91803
19	Base Back Panel Assembly (includes #16, #20 & #23) – 16-7/8" Wide Module 211A-04 ³	–	90934
	Base Back Panel Assembly (includes #16, #20 & #23) – 22-1/2" Wide Module 211A-05 ³	–	91804
	Base Back Panel Assembly (includes #16, #20 & #23) – 28-1/8" Wide Module 211A-06 ³	–	91805
	Base Back Panel Assembly (includes #16, #20 & #23) – 33-3/4" Wide Module 211A-07 ³	–	91806
	Base Back Panel Assembly (includes #16, #20 & #23) – 39-3/8" Wide Module 211A-08 ³	–	
20	Base Panel Insulation (includes Front & Back) – for 16-7/8" Wide Module 211A-04 ³	–	90328
	Base Panel Insulation (includes Front & Back) – for 22-1/2" Wide Module 211A-05 ³	–	90329
	Base Panel Insulation (includes Front & Back) – for 28-1/8" Wide Module 211A-06 ³	–	90330
	Base Panel Insulation (includes Front & Back) – for 33-3/4" Wide Module 211A-07 ³	–	90331
	Base Panel Insulation (includes Front & Back) – for 39-3/8" Wide Module 211A-08 ³	–	90332
21	Burner Support Channel – for 16-7/8" Wide Module 211A-04 ³	–	90585
	Burner Support Channel – for 22-1/2" Wide Module 211A-05 ³	–	90586
	Burner Support Channel – for 28-1/8" Wide Module 211A-06 ³	–	90587
	Burner Support Channel – for 33-3/4" Wide Module 211A-07 ³	–	90588
	Burner Support Channel – for 39-3/8" Wide Module 211A-08 ³	–	90589
22	Base Front Panel Cover Plate – for 16-7/8" Wide Module 211A-04 ³	–	90316
	Base Front Panel Cover Plate – for 22-1/2" Wide Module 211A-05 ³	–	90318
	Base Front Panel Cover Plate – for 28-1/8" Wide Module 211A-06 ³	–	90320
	Base Front Panel Cover Plate – for 33-3/4" Wide Module 211A-07 ³	–	90322
	Base Front Panel Cover Plate – for 39-3/8" Wide Module 211A-08 ³	–	90324
23	Base Back Panel Cover Plate – for 16-7/8" Wide Module 211A-04 ³	–	90317
	Base Back Panel Cover Plate – for 22-1/2" Wide Module 211A-05 ³	–	90319
	Base Back Panel Cover Plate – for 28-1/8" Wide Module 211A-06 ³	–	90321
	Base Back Panel Cover Plate – for 33-3/4" Wide Module 211A-07 ³	–	90323
	Base Back Panel Cover Plate – for 39-3/8" Wide Module 211A-08 ³	–	90325

³ See IOM Figure 2.1 and Table 2.1 for Base Assembly

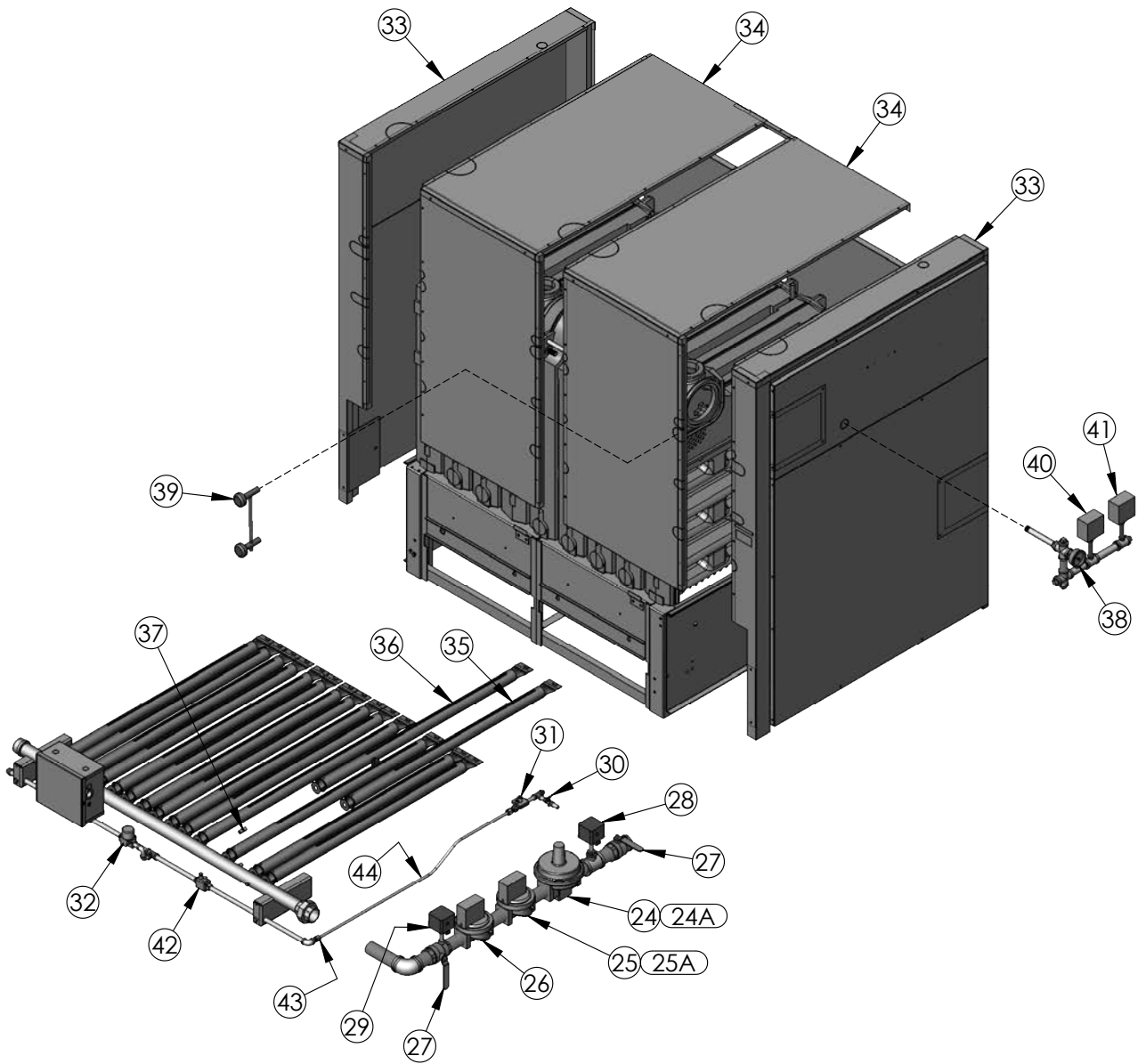

Figure 15.3: Jacket/Burner/Gas Manifold Repair Parts

Table 15.3: Typical Jacket/Burner/Gas Manifold Repair Parts

	Description	Quantity Required	Stock Code
24	Gas Pressure Regulator – 1" RV61 (Cad. Spring 2-5" w.c. Nat. Gas)	–	50645
	Gas Pressure Regulator – 1-1/4" RV81 (Cad. Spring 2-5" w.c. Nat. Gas)	–	50647
	Gas Pressure Regulator – 1-1/2" RV81 (Cad. Spring 2-5" w.c. Nat. Gas)	–	50646
	Gas Pressure Regulator – 2" RV91 (Cad. Spring 2-5" w.c. Nat. Gas)	–	50648
	Gas Pressure Regulator – 2-1/2" RV111 (Cad. Spring 2-5" w.c. Nat. Gas)	–	50642
	Gas Pressure Regulator – 3" RV111 (Cad. Spring 2-5" w.c. Nat. Gas)	–	50641
24A	Gas Pressure Regulator Vent Limiter – 12A06 1/8" NPT	–	50656
25-26	Gas Safety Valve – 1" V48A2169 – Diaphragm-Type 120 VAC	–	50598
	Gas Safety Valve – 1-1/4" V48A2177 – Diaphragm-Type 120 VAC	–	50599
	Gas Safety Valve – 1-1/4" K3A672S – Solenoid-Type 120 VAC (When Used)	–	50743
	Gas Safety Valve – 1-1/2" V48A2185 – Diaphragm-Type 120 VAC	–	50600
	Gas Safety Valve – 2" V48A2243 – Diaphragm-Type 120 VAC	–	50601
	Gas Safety Valve – 2" S261SG02N3JK4 – Soenoid-Type 120 VAC (When Used)	–	50746
	Gas Safety Valve – 2-1/2" V48A2250 – Diaphragm-Type 120 VAC	–	50602
	Gas Safety Valve – 2-1/2" S261SH02N3KK4 – Solenoid-Type 120 VAC (When Used)	–	51025
	Gas Safety Valve – 3" V48A2169 – Diaphragm-Type 120 VAC	–	50603
	Gas Safety Valve – 3" K3E52A2 – Solenoid-Type 120 VAC (When Used)	–	50745
25A	Bleed Restrictor for V48A Diaphragm Gas Valve – 126590	–	50631
27	Manual Gas Valve – 1" 50-GB5-A1	–	51703
	Manual Gas Valve – 1-1/4" 50-GB6-A1	–	51704
	Manual Gas Valve – 1-1/2" 50-GB7-A1	–	51705
	Manual Gas Valve – 2" 50-GB8-A1	–	51706
	Manual Gas Valve – 2-1/2" 50-803-08	–	50524
	Manual Gas Valve – 3" 64-100-01	–	50568
28	Low Gas Pressure Switch C6097A – 1/4" NPT 3-21" w.c. Manual Reset (When Used)	–	50700
29	High Gas Pressure Switch C6097B – 1/4" NPT3-21" w.c. Manual Reset (When Used)	–	50701
30	Manual Gas Valve – Pilot – 1/4" NPT 94MBV03	–	50559
31	Pilot Gas Regulator – 1/4" NPT RV20L (2-5" w.c. Nat. Gas)	–	50643
32	Pilot Gas Valve – 1/4" NPT H91BA-3 120 VAC - E*-E Ignition	–	50753
	Pilot Gas Valve – 1/4" NPT H91BG-2 24 VAC - HSP Ignition	–	50754
33	Common End Panel and Cleanout Cover Plate Assembly – Carton No. 12	–	90282
34	Intermediate Panel Jacket Assembly – Carton 12A – 211A-04	–	90283
	Intermediate Panel Jacket Assembly – Carton 12B – 211A-05	–	90284
	Intermediate Panel Jacket Assembly – Carton 12C – 211A-06	–	90285
	Intermediate Panel Jacket Assembly – Carton 12D – 211A-07	–	90286
	Intermediate Panel Jacket Assembly – Carton 12E – 211A-08	–	90287
35	Steel Burner	–	51045
36	Steel Burner w/ Pilot Mounting Clip	–	51046
37	Gas Orifice Spud – Natural Gas/0-2000 Feet Above MSL Altitude	–	51730
	Gas Orifice Spud – LP Gas/0-3000 Feet Above MSL Altitude	–	X4003-33LP
	Gas Orifice Spud – High Altitude (Specify Altitude & Fuel)	–	Call Factory
38	Steam Gauge – 30 psig	–	51769
39	Gauge Glass Set	–	50513
40	Operating Control – PA404A1009 Auto Reset (Standard)	–	50549
	Operating Control – L404F1060 Auto Reset (Optional)	–	50680
41	High Limit – L4079B1033 – Manual Reset	–	50681
42	Thermo Pilot Valve – 3/8" NPT H17CA-1 (where used)	–	50752
43	3/8" O.D. x 1/4" NPT Adapter	–	53
44	3/8" O.D. Aluminum Tubing	–	719

Table 15.4: Typical Ignition System Repair Parts

	Description	Stock Code
E*-E Ignition System		
–	Ignition Control - Honeywell RM7890A1056	50665
–	Ignition Control Sub-base - Honeywell Q7800B1003	50660
–	Ignition Control Amplifier - Honeywell R7847A1033	90807
–	Ignition Transformer - Allanson 1092F	51299
–	Pilot - Honeywell Q179C1009 - Natural Gas (use with 50635 on LP)	50550
–	Pilot Orifice - Honeywell 388146KD - LP Gas	50635
–	Pilot - Honeywell Q327A1626 - Natural Gas (where used)	50677
–	Pilot - Honeywell Q327A1147 - LP Gas (where used)	50557
HSP Ignition System		
–	Ignition Control - Honeywell S8610M3009	50672
–	Pilot - Honeywell Q3481B1644 - Natural Gas, with lead	50996
–	Pilot - Honeywell Q3481B - LP Gas, with lead	50997
–	Relay - Honeywell R8222A1002 (2 required)	50566
–	Transformer - Johnson 100VA	51716
–	Transformer - RIB 40VA	50791

Series 211A™

Gas Boilers – Steam

Installation, Operation & Maintenance Manual

TO THE INSTALLER:

This manual is the property of the owner and must be affixed near the boiler for future reference.

TO THE OWNER:

This boiler should be inspected annually by a Qualified Service Agency.



PeerlessBoilers.com

PB HEAT, LLC

131 S. CHURCH STREET • BALLY, PA 19503