

SPECIFICATION AND SUBMITTAL

GB1-CT 15 GPM Super-Capacity Grease Interceptor for Indoor Use

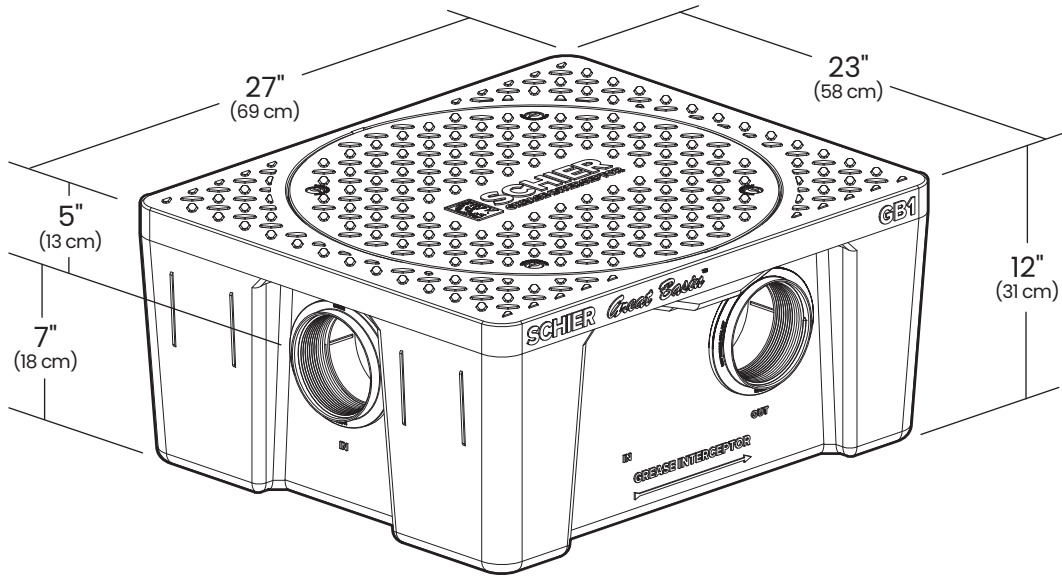

SUBMITTAL

Standard

Location: indoor
Installation: above/below grade
Flow Rates / Grease Capacities:
 15 GPM (0.9 L/s) / 70 lbs. (31.8 kg)
Solids Capacity: 1.3 gal. (4.9 L)
Liquid Capacity: 10 gal. (37.9 L)
Weight: 39 lbs. (17.7 kg)
Connections: 2" (50 mm) and 3" (75 mm) plain end
Cover: bolted gas/water tight polypropylene with 1,000 lb. load rating when unit is buried with FCRI riser

Options

- FCRI (x1):** > 2-1/8" - 12" field cut riser
- FCRI (x2):** > 12" - 24" field cut risers
- CCI:** membrane clamping collar kit (requires FCRI riser)
- PPI:** pumpout port kit
- PLAIN-EA-44:** 4" (100 mm) plain end fitting
- FPT-EA-34:** 4" x 3" (100 mm x 75 mm) FPT fitting
- FPT-EA-23:** 3" x 2" (75 mm x 50 mm) FPT fitting

Approval

Signature:	Date:	Company:
Specifying Engineer:		Engineering Firm:



MODEL NUMBER:
GB1-CT

DESCRIPTION: 15 GPM Polyethylene Super-capacity Grease Interceptor

PART #: 4060-101-04

DWG BY: B. Karrer

DATE: 4/01/2019

REV:

ECO:



SPECIAL PRECAUTIONS

For Schier Grease Interceptor Installations - Failure to follow this guidance voids your warranty

WARNING! DO NOT AIR TEST UNIT OR RISER SYSTEM!
Doing so may result in property damage, personal injury or death.

CAUTION! Do not install this unit in any manner except as described in the installation instructions.

Installation Instructions

Installation instructions and additional components are included with the interceptor. Read all instructions prior to installation. This interceptor is intended to be installed by a licensed plumber in conformance with all local codes.

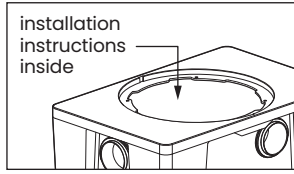

When Installing Interceptor Inside

If your dishwashing sink(s) discharges into a floor drain/sink (drain), you must regulate the flow into the drain to avoid an overflow of water onto the kitchen floor. This can be done by installing a valve or flow restriction cap on the sink piping that discharges into the drain. See drawing for guidance. For detailed guidance on indirect connections, go to: webtools.schierproducts.com/Technical_Data/Indirect_Connections.pdf

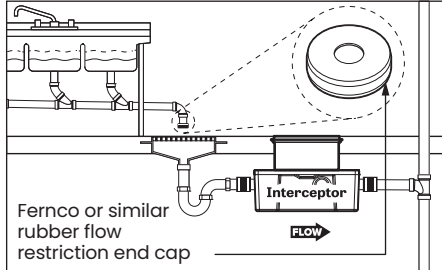

Flush-to-Grade Burials

Flush-to-Grade buried installations (without a riser) are not recommended for heavy foot traffic areas without the use of an internal gusset support kit **SGK2** (for GB2) or **SGK3** (for GB3).

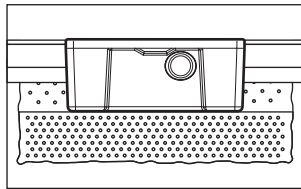

High Temperature Kitchen Water

If water is entering the interceptor at excessive temperature (over 140° F), a drain water tempering valve (DTV) and approved backflow prevention assembly must be installed. Most state and local plumbing codes prohibit water above 140° F being discharged into the sanitary sewer. Water above 140° F will weaken or deform PVC Schedule 40 pipe, poly drainage fixtures like interceptors and erode the coating of cast iron (leading to eventual failure).

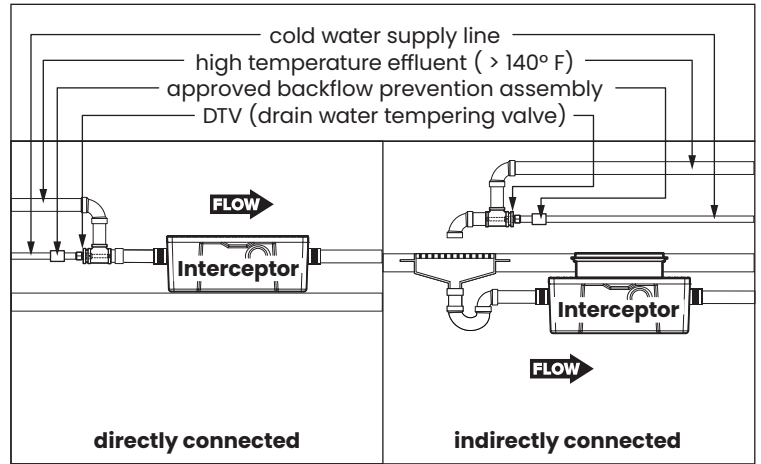

Fully Support Base of Unit

Install unit on solid, level surface in contact with the entire footprint of unit base; for suspended installations design trapeze to support the wet weight of the unit. Do not partially support unit or suspend unit using metal U-channel to create a trapeze

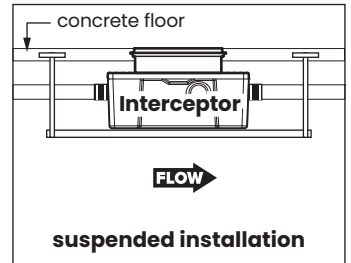

Support Inlet and Outlet Piping

For above grade installations ensure heavy inlet and outlet piping (such as cast iron or long runs) is properly supported or suspended during the entire installation process to prevent connection failure or damage to bulkhead fittings.

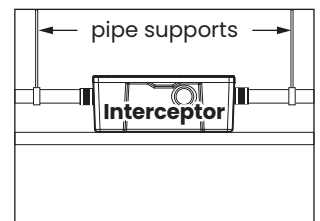

SCHIER
LIFETIME GUARANTEED
GREASE INTERCEPTORS

MODEL NUMBER:
GB1-CT

DESCRIPTION: 15 GPM Polyethylene
Super-capacity Grease Interceptor

PART #: 4060-101-04

DWG BY: B. Karrer

DATE: 4/01/2019

REV:

ECO:

SPECIFICATIONS

Notes

1. 4" FPT inlet/outlet with 2" and 3" plain end fittings.
2. Unit weight - 39 lbs. (wet weight 123 lbs.)
3. Capacities - Liquid: 10 gal.
@15 GPM- Grease: 70 lbs. (9.6 gal.)
Solids: 1.3 gal.
4. Built-in flow control.
5. For gravity drainage applications only.
6. Do not use for pressure applications.
7. Cover placement allows full access to tank for proper maintenance.
8. Vent not required unless per local code.
9. Engineered inlet and outlet diffusers are removable to inspect/clean piping.
10. Integral air relief / anti-siphon.

Engineer Specification Guide

Schier Great Basin™ grease interceptor model # GBI-CT shall be lifetime guaranteed and made in USA of seamless, rotationally-molded polyethylene. Interceptor shall be furnished for above or below grade installation. Interceptor shall be certified to ASME A112.14.3 (type C) and CSA B481.1, with field cut riser system, built-in flow control and three outlet options. Interceptor flow rate shall be 15 GPM. Interceptor grease capacity shall be 70 lbs. Cover shall provide water/gas-tight seal and have minimum 450 lbs. load capacity.

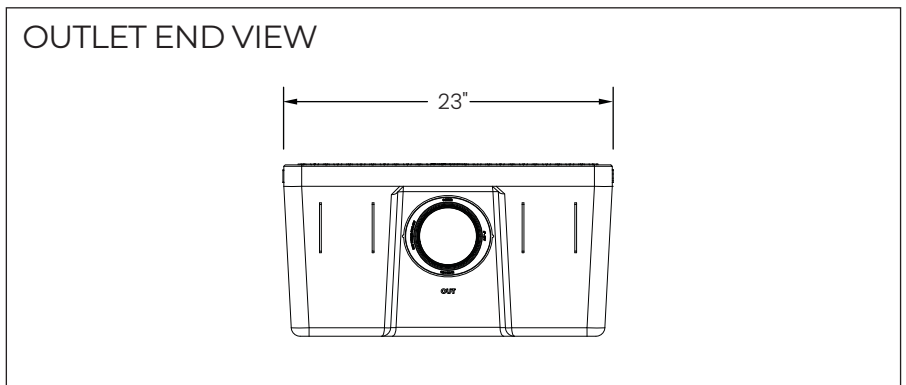
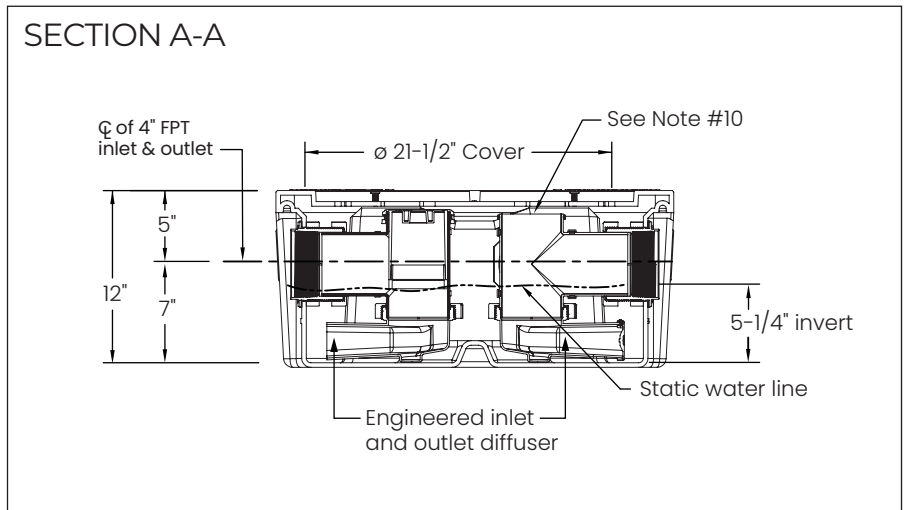
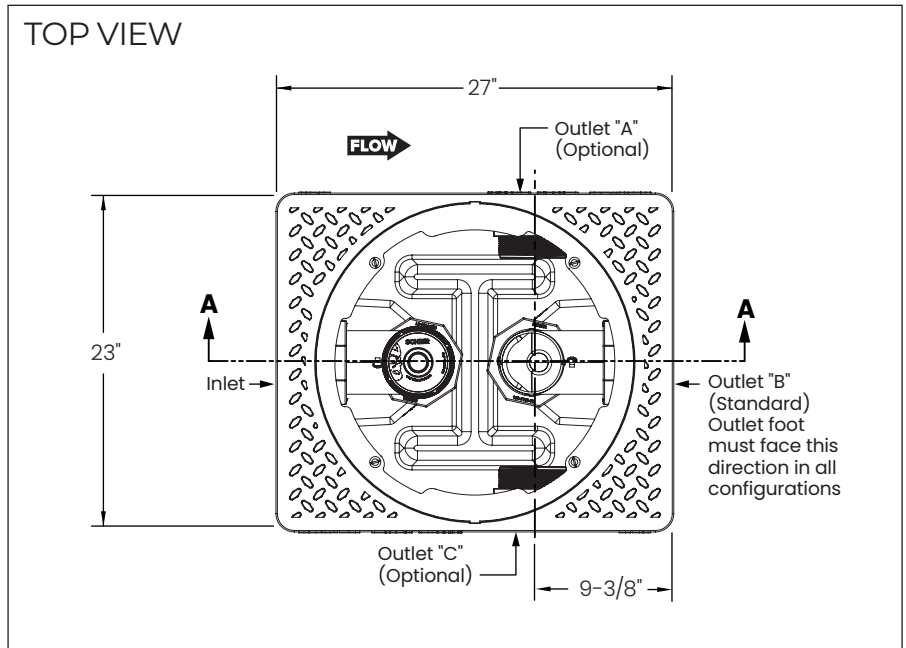

SCHIER
LIFETIME GUARANTEED
GREASE INTERCEPTORS

MODEL NUMBER:
GBI-CT

DESCRIPTION: 15 GPM Polyethylene
Super-capacity Grease Interceptor

PART #: 4060-101-04

DWG BY: B. Karrer

DATE: 4/01/2019

REV:

ECO: