

THIS SPACE FOR DESIGNER/ENGINEER APPROVAL

Job/Customer _____	Date _____	Contractor _____
Model Specified _____	Qty _____	Approved By _____
Designer/Engineer _____	Date _____	Contractor's PO# _____
Submitted by _____	Date _____	Other _____

4141HV-RF Series
Full Port Forged Brass Uni-Flange Ball Valve
w/ Detachable Rotating Round Flange
Multi-Function Hi-Flow Hose Drain
Adjustable Packing Gland, Nuts & Bolts
Fits High Efficiency Variable Speed Pumps
IPS x Rotating Flange
600 WOG
ISO 9001 - Patented Technology



ITEM #	SIZE	CTN	CASE	A	B	C	D	E	F	G	H	I	J	K	L
41416HV-RF375	1 1/2	1	6	1 1/2	4	3 3/8	3 3/8	7/16	5/8	1 1/2	3 7/8	5	2 11/16	5/8	1/2-13 x 2 1/4
41417HV-RF400	2	1	6	2	4 3/8	3 1/2	3 3/8	1/2	9/16	2	4	5 1/4	-	-	1/2 -13 x 2 1/4
41417HV-RF475	2	1	6	2	4 3/8	3 1/2	3 3/8	7/16	-	2	-	6 1/8	4	13/16	5/8-11 x 2 1/4



NO.	DESCRIPTION	MATERIAL
1	FLANGED BODY	BRASS
2	END CAP	BRASS
3	SEATS	PTFE
4	BALL	BRASS HCP
5	STEM	BRASS
6	STEM SEAL	PTFE
7	PACKING GLAND	BRASS
8	LEVER HANDLE	STEEL CP
9	HANDLE NUT	STAINLESS STEEL
10	HANDLE JACKET	VINYL
11	ROTATING FLANGE	DUCTILE IRON
12	ROTATING FLANGE RING	STAINLESS STEEL
13	FLANGE BOLTS & NUTS	STEEL ZP
14	DRAIN SEATS	PTFE
15	DRAIN BALL	BRASS CP
16	DRAIN STEM	BRASS
17	DRAIN END CAP	BRASS
18	DRAIN HANDLE	EPOXY COATED ALUMINUM
19	STEM SEAL	PTFE
20	PACKING GLAND	PTFE
21	SCREW	STAINLESS STEEL
22	CAP	BRASS
23	STRAP	PVC

TEMP °F	PSI
100	600
150	485
200	395
250	210
300	N/A
350	N/A
366	N/A



Quality and Commitment Since 1954

www.webstonevalves.com · P: (800) 225-9529 · F: (800) 336-5133

Webstone product specifications in U.S. customary units are approximate and are provided for reference only. Webstone reserves the right to change or modify product design, construction, specifications or materials without prior notice and without incurring any obligation to make such changes and modifications on Webstone products previously or subsequently sold.

4141HV-RF-spec_03302016

THIS SPACE FOR DESIGNER/ENGINEER APPROVAL

Job/Customer _____	Date _____	Contractor _____
Model Specified _____	Qty _____	Approved By _____
Designer/Engineer _____	Date _____	Contractor's PO# _____
Submitted by _____	Date _____	Other _____

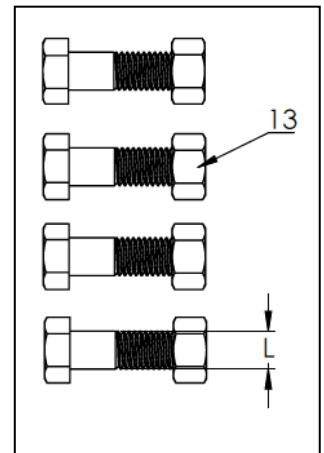
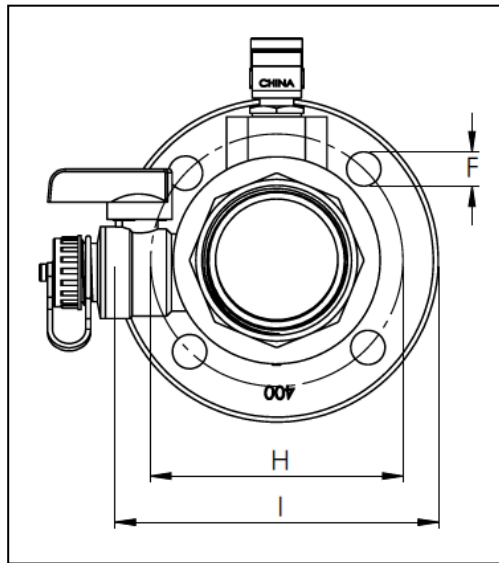
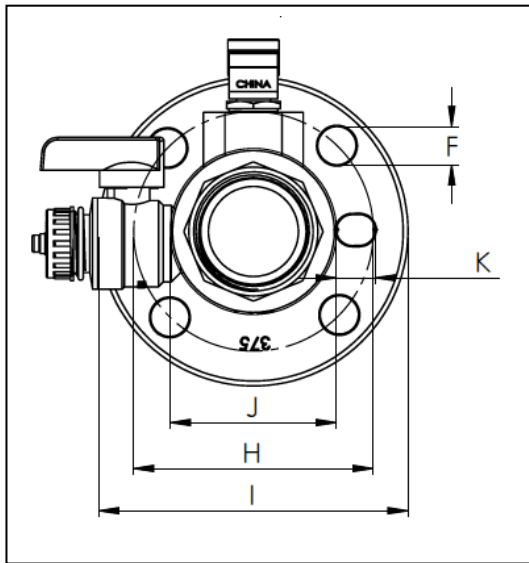
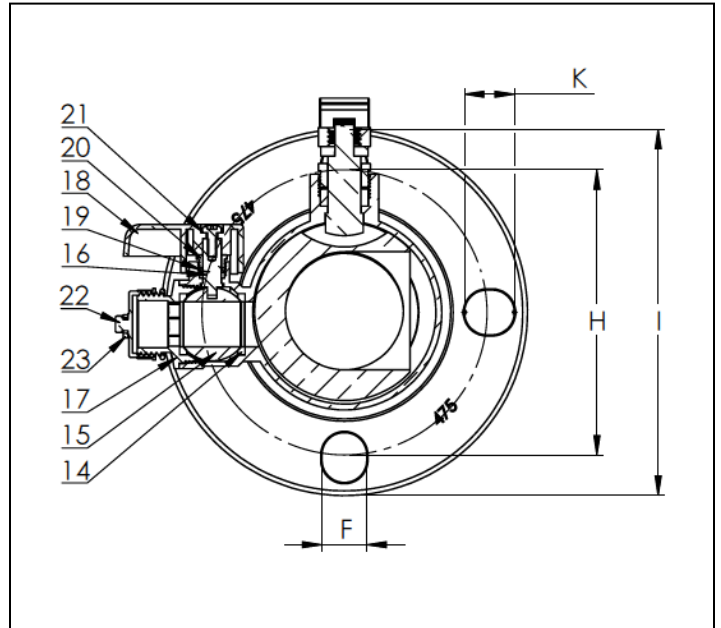
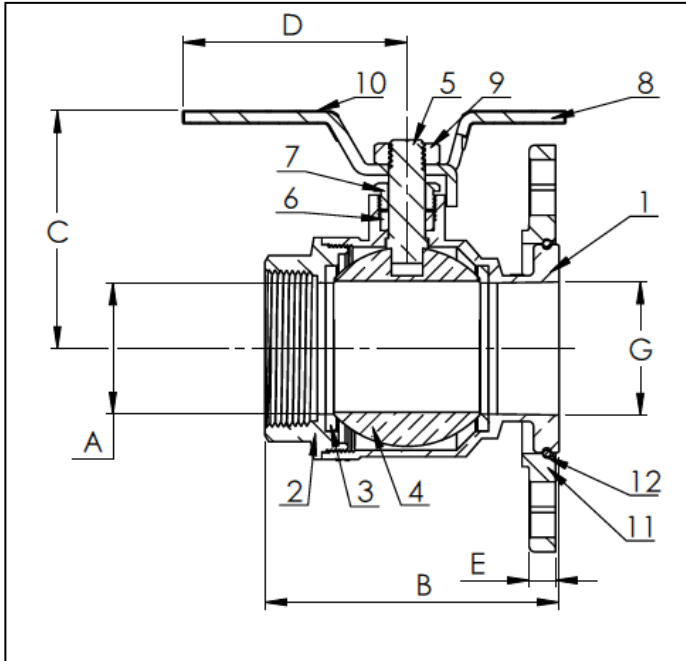

Specifications: Designed for residential, commercial or industrial use with water or a glycol mixture. This approved Webstone valve is actuated by a blowout proof stem and features an adjustable packing gland. Flange features a conical inlet to minimize turbulence. The rotating flange is secured by a snug-fit snap-ring that provides greater control over positioning during installation. Threaded ends comply with ANSI B1.20.1. HV models fit both standard and high velocity pumps.

Webstone
VALVE INNOVATION

Quality and Commitment Since 1954

www.webstonevalves.com · P: (800) 225-9529 · F: (800) 336-5133

Webstone product specifications in U.S. customary units are approximate and are provided for reference only. Webstone reserves the right to change or modify product design, construction, specifications or materials without prior notice and without incurring any obligation to make such changes and modifications on Webstone products previously or subsequently sold.

4141HV-RF-spec_03302016