

GP1402-1.28-TS

HIGH EFFICIENCY TOILET FLUSH VALVE
(1.28 gpf / 4.8 Lpf per flush)

TruEDGE

Description

Battery powered, sensor activated, diaphragm operated, chrome plated exposed flush valve for 1-1/2" floor mounted or wall hungtop spud water closet.

Flush Cycle

1.28 gpf / 4.8 Lpf High Efficiency

Specification

- 1" vandle proof TruStop ball valve designed angle control stop with TruChek.
- SmartChoice Technology software provides field adjustability for True-in-the-Field Water Conservation
- Remote for Range & Discharge Adjustability.
- Mashaerator self-cleaning diaphragm.
- Chloramine resistant diaphragm.
- 6 Volt DC latching solenoid valve
- 6 Volt DC litium batter (2C-P2 type).
- Infrared sensor with Dual Infrared Transmitter Technology.
- Arming delay of 10 seconds prevents unintentional flushes.
- Electronic courtesy flush push button.
- Renewable main valve seat.
- Sweat Adapter Kit.
- Vacuum Breaker w/ 9" flush connection.
- Wall flange, spud nut and spud flange for 1-1/2" top spud.
- All rubber parts molded of chloramine resistant rubber.

Variations

- GJ - Ground Jount Tailpiece
- SC - SlipFit Connection (adjustable joint tailpiece)
- G - Bumper on angle stop (for seat without cover)
- T36 - Solid ring wall support for flush connection
- T46 - Split ring wall support for flush connection
- TS - TruStop - Ball valve designed Control Stop
- VPS - Vandal Proof Control Stop with Key

Valve is in compliance with the applicable sections of ASSE 1037.

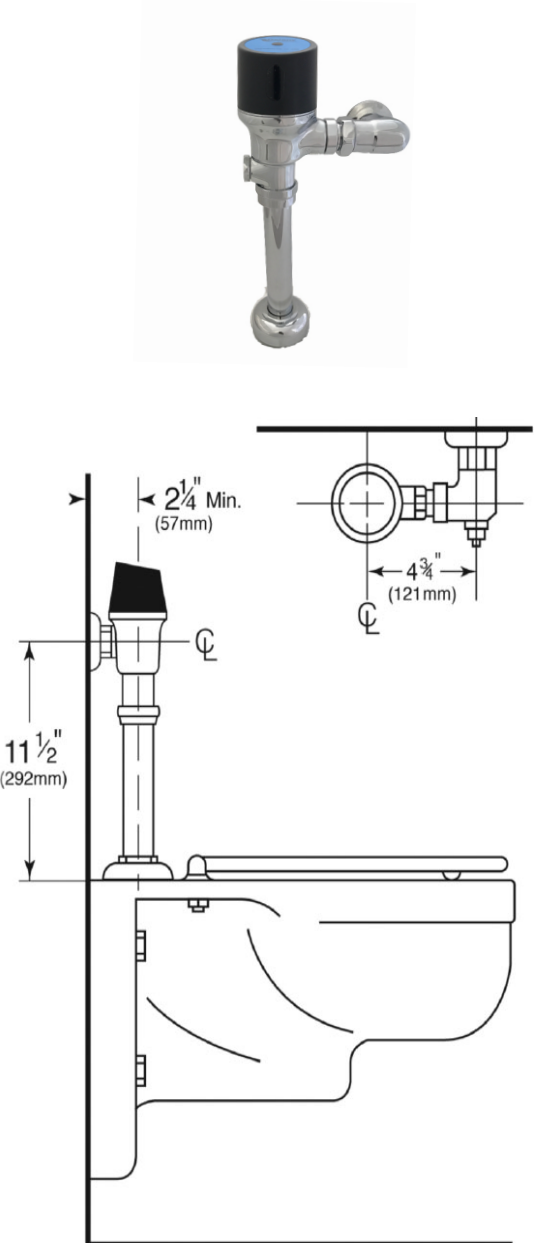

Note: Min.roughing height 10 1/2" centerline of supplu to top of fixture.

