

MOLDED

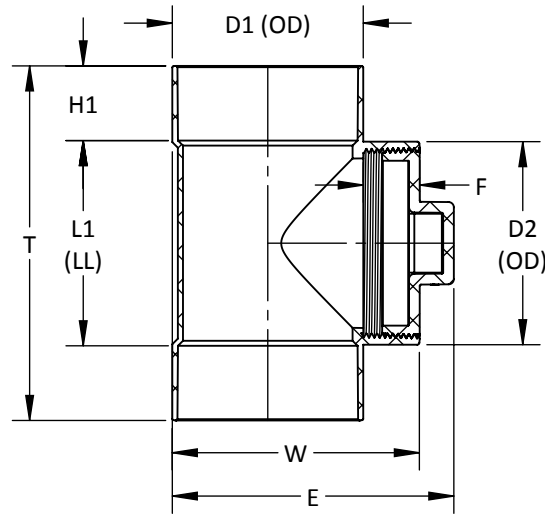

ASTM D2665, F1866, CSA B181.2 WHERE APPLICABLE

**TEST TEE WITH RAISED PLUG HxHxFIPT  
PVC SOLVENT WELD DWV**

PART NO.	SIZE IN INCHES	L1	H1	F	T	W	E	D1	D2
* D12904	4 x 4	5 3/16	1 25/32	1 1/4	8 3/4	6 1/8	6 15/16	5 1/32	5 1/32
* D12906-4	6 x 4	5 3/16	3 1/16	1 1/4	11 5/16	8 15/32	9 9/32	7 7/32	5 1/32
* D12906	6 x 6	7 1/4	3 1/16	1 5/8	13 3/8	8 3/4	9 23/32	7 7/32	7 7/32
* D12908-4	8 x 4	5 7/16	4 1/16	1 1/4	13 9/16	10 7/32	11 1/32	9 11/32	5 1/32
* D12908-6	8 x 6	7 7/16	4 1/16	1 5/8	15 9/16	10 7/8	11 27/32	9 11/32	7 7/32
* D12908	8 x 8	9 5/16	4 1/16	1 13/16	17 7/16	10 7/8	11 15/16	9 11/32	9 11/32
* D12910-4	10 x 4	6 1/2	5 1/16	1 1/2	16 5/8	13 5/8	14 7/16	11 17/32	5 1/32
* D12910-6	10 x 6	8 11/16	5 1/16	1 5/8	18 13/16	13 13/16	14 25/32	11 17/32	7 7/32
* D12910-8	10 x 8	10 15/16	5 1/16	1 13/16	21 1/16	14 3/32	15 5/32	11 17/32	9 11/32
* D12910	10 x 10	12 7/8	5 1/16	1 7/8	23	13 29/32	14 7/8	11 17/32	11 17/32
* D12912-4	12 x 4	6 7/8	6 1/16	1 1/4	19	15 5/8	16 7/16	13 19/32	5 1/32
* D12912-6	12 x 6	8 7/8	6 1/16	1 5/8	21	15 27/32	16 13/16	13 19/32	7 7/32
* D12912-8	12 x 8	11 1/16	6 1/16	1 13/16	23 3/16	16 1/8	17 3/16	13 19/32	9 11/32
* D12912-10	12 x 10	12 7/8	6 1/16	1 7/8	25	16	16 31/32	13 19/32	11 17/32
* D12912	12 x 12	15 1/16	6 1/16	1 29/32	27 3/16	16 7/32	17 5/32	13 19/32	13 19/32

-- DIMENSIONS AND APPEARANCE ARE APPROXIMATE AND SUBJECT TO CHANGE  
WITHOUT NOTICE DUE TO DESIGN OR PRODUCTION MODIFICATIONS  
-- MOLDED FITTING TOLERANCE = ±1/8" OVERALL LENGTH  
-- FABRICATED FITTING TOLERANCE = ±1" LINEAR, ± 2° ANGULAR

\* MOLDED FITTING  
† ASSEMBLED FROM MOLDED COMPONENTS  
ALL OTHER FITTINGS ARE FABRICATED