



HARTELL PUMPS



RESERVOIR STYLE DRAIN PUMPS

LTP-1 LTS-1

(801284)

(801285)

- ◆ 2 GALLON POLYPROPYLENE RESERVOIR.
- ◆ UNITIZED CONSTRUCTION.
- ◆ SUDS-PROOF DESIGN.
- ◆ FITS INSIDE 24" BASE CABINETS AND VANITIES.
- ◆ FITS UNDER UTILITY SINKS.
- ◆ ALLOWS SINK INSTALLATION WITHOUT BREAKING CONCRETE TO DRAIN.
- ◆ NO MAIN STACK VENT CONNECTION REQUIRED.¹

¹N.S.P.C. SECTION 11.7.9, CHECK LOCAL CODES

PUMP PERFORMANCE

	LTP-1 801284	LTS-1 801285
LIFT (FEET)	FLOW (GPM)	
4.0	44.0	48.0
8.0	34.5	39.5
12.0	7.5	26.4
16.0	—	4.7
MAXIMUM LIFT	13.0FEET	16.5FEET

NOTE: ACTUAL FLOW WILL VARY WITH LINE LOSSES

SPECIFICATIONS	LTP-1 801284	LTS-1 801285
MOTOR: (HP @ RPM)	1/4 @ 1725	1/3 @ 1725
ELECTRICAL	115V 5.0A*	115V 5.6A*
INLET SIZE	1 1/2" NPT FEMALE	1 1/2" NPT FEMALE
DISCHARGE SIZE	1" NPT FEMALE	1" NPT FEMALE
RESERVOIR CAPACITY	2.0 GALLONS	2.0 GALLONS
UNIT DIMENSIONS (WxDxH)	10"x12"x17"	10"x12"x17"
MAXIMUM TEMPERATURE	130° F	130° F



HARTELL PUMPS **201 IVYLAND ROAD** **IVYLAND, PA 18974**
 TELEPHONE: 215-322-0730 FAX: 215-322-2944 E-MAIL: INFO@HARTELL.COM

SPECIFICATIONS	LTP-1 (801284)	LTS-1 (801285)
MOTOR: (HP @ RPM)	1/4 @ 1725	1/3 @ 1725
ELECTRICAL	115 V 5.0 A	115 V 5.6 A
INLET SIZE	1 1/2" NPT FEMALE	
DISCHARGE SIZE	1" NPT FEMALE	
RESERVOIR	2 GALLON - POLYPROPYLENE	
UNIT DIMENSIONS	10" x 12" x 17"	
MAXIMUM TEMPERATURE	130° F	
SHAFT MATERIAL	ALUMINUM	STAINLESS STEEL
IMPELLER MATERIAL	CAST ALUMINUM	
POWER CORD	7 1/2 FOOT, GROUNDING	
SWITCH	60 AMP SURGE RATED SEALED - DOUBLE CONTACT	

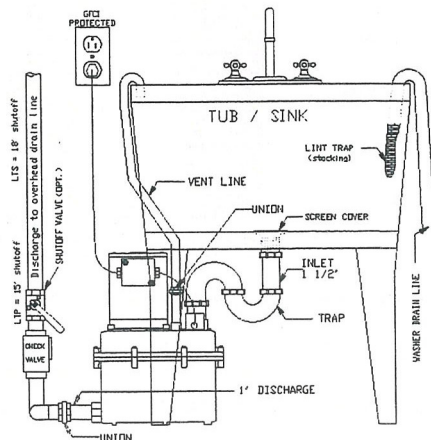
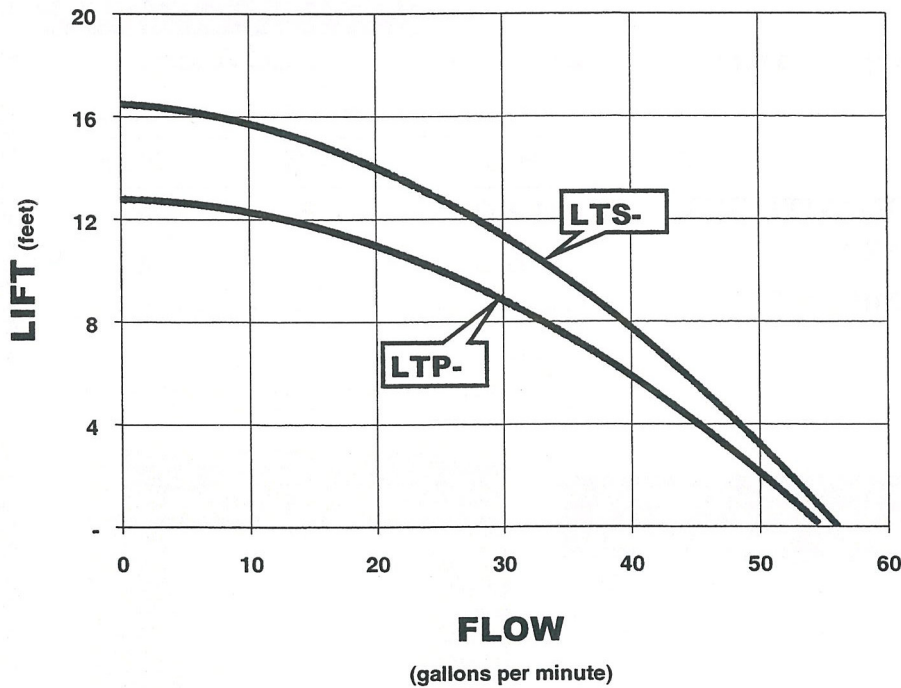
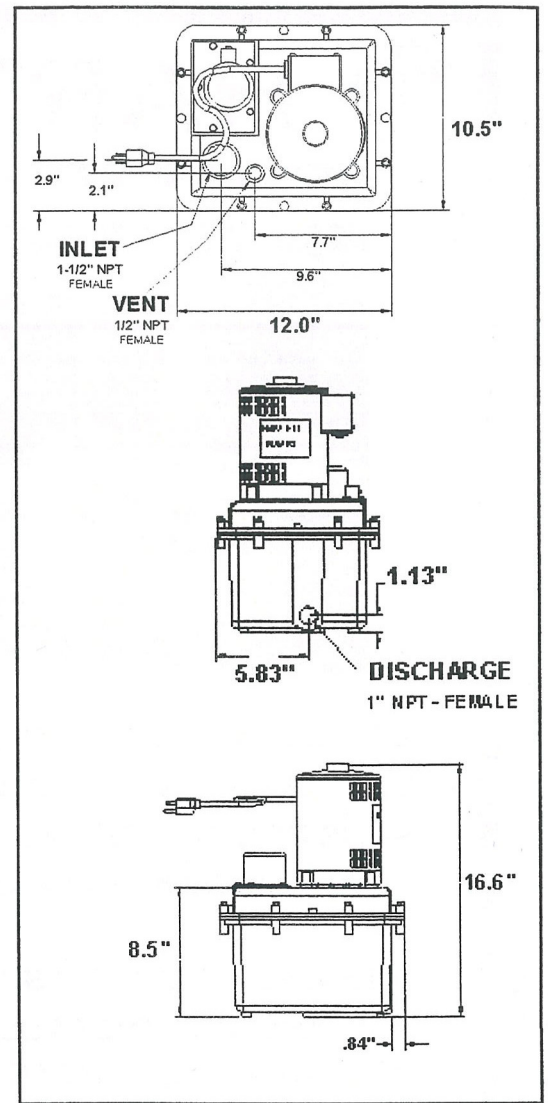

Hartell
MILTON ROY

IVYLAND, PA 18974

PHONE: 215-322-0730

FAX: 215-322-2944

E-MAIL: info@hartell.com

WEB SITE: WWW.HARTELL.COM