

**SPECIFICATIONS**

1. 2" plain end inlet/outlet.
2. Max flow rate: 15 GPM
3. Capacities: Liquid: 15 gal. (2 cu. ft.); Oil: 10 gal.; Sand: 1 gal.
4. Unit weight w/std. covers: 28 lbs.
5. Standard cover handles 450 lbs. when unit is directly buried and 2,500 lbs. when buried with SR16 riser.
6. Maximum operating temperature 140°F continuous.

**NOTES**

1. Snap-in Flow control (ships with unit).
2. For gravity drainage applications only. Do not use for pressure applications.
3. Seamless medium density polyethylene tank.
4. Cover placement allows full access to tank for proper maintenance.
5. Engineered inlet and outlet diffusers are removable to inspect/clean piping.
6. For on the-floor or buried applications.

**DIFFUSION FLOW TECHNOLOGY**

The inlet diffuser splits influent into three paths, creating laminar flow and utilizing the entire liquid volume of the tank for efficient oil separation. The calibrated openings greatly reduce influent turbulence. The influent enters the main chamber without disturbing the existing oil or sand layers. The bottom of the outlet diffuser allows only effluent that is free of oil to exit the tank.

**ENGINEER SPECIFICATION GUIDE**

Striem Oil Reserve™ oil/sand separator model OS-15 shall be lifetime guaranteed and made in USA of seamless, rotationally-molded polyethylene. Separator shall be furnished for above or below grade installation, with field adjustable riser system, snap-in flow control and (2) vent connections. Separator flow rate shall be 15 GPM. Separator oil capacity shall be 10 gallons. Sand capacity shall be 1 gallon. Cover shall provide water/gas-tight seal and have a maximum 450 lbs load capacity.

**OPTIONS**

- 2M** - Mail Thread Inlet / Outlet
- 3P** - 3" Plain End SCH.40 Inlet / Outlet
- 3M** - 3" Male Thread Inlet / Outlet
- SR16** - 2-1/16"-16" 16 Series Riser
- CC16** - 2-1/16"-16" 16 Series Riser with Integral Membrane Clamping Collar Kit

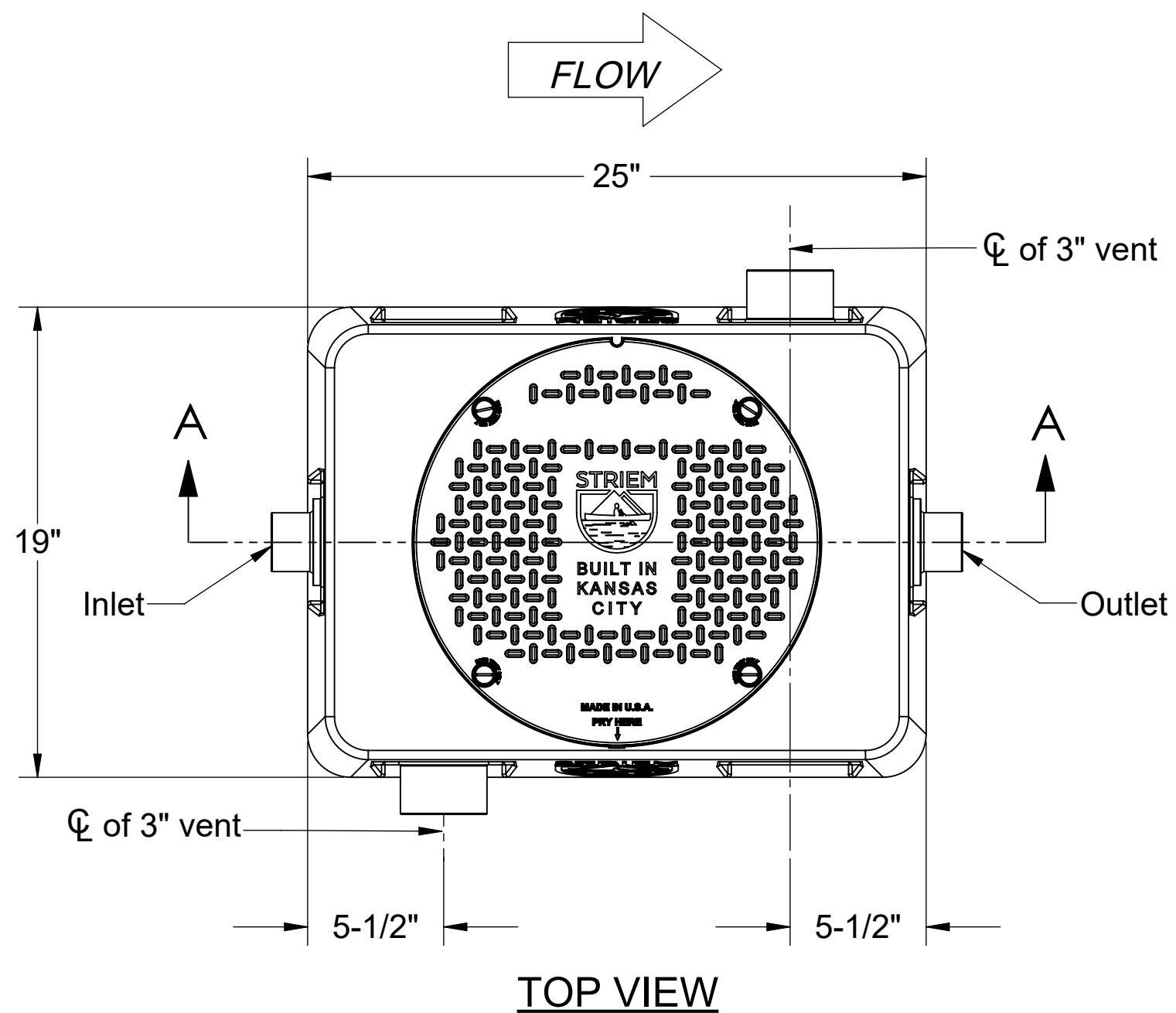

**TOP VIEW**

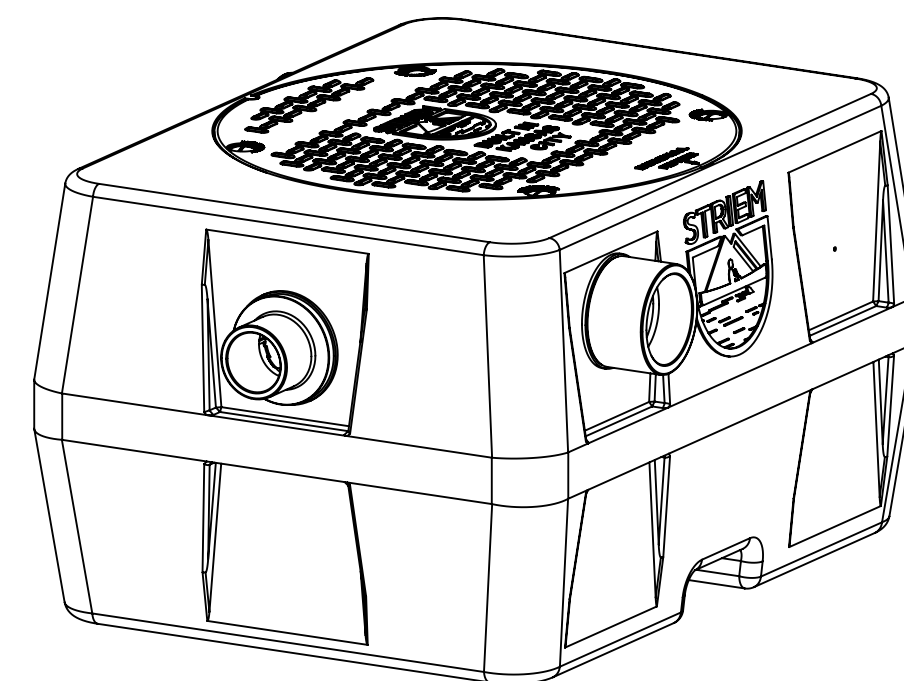

**ISOMETRIC VIEW**

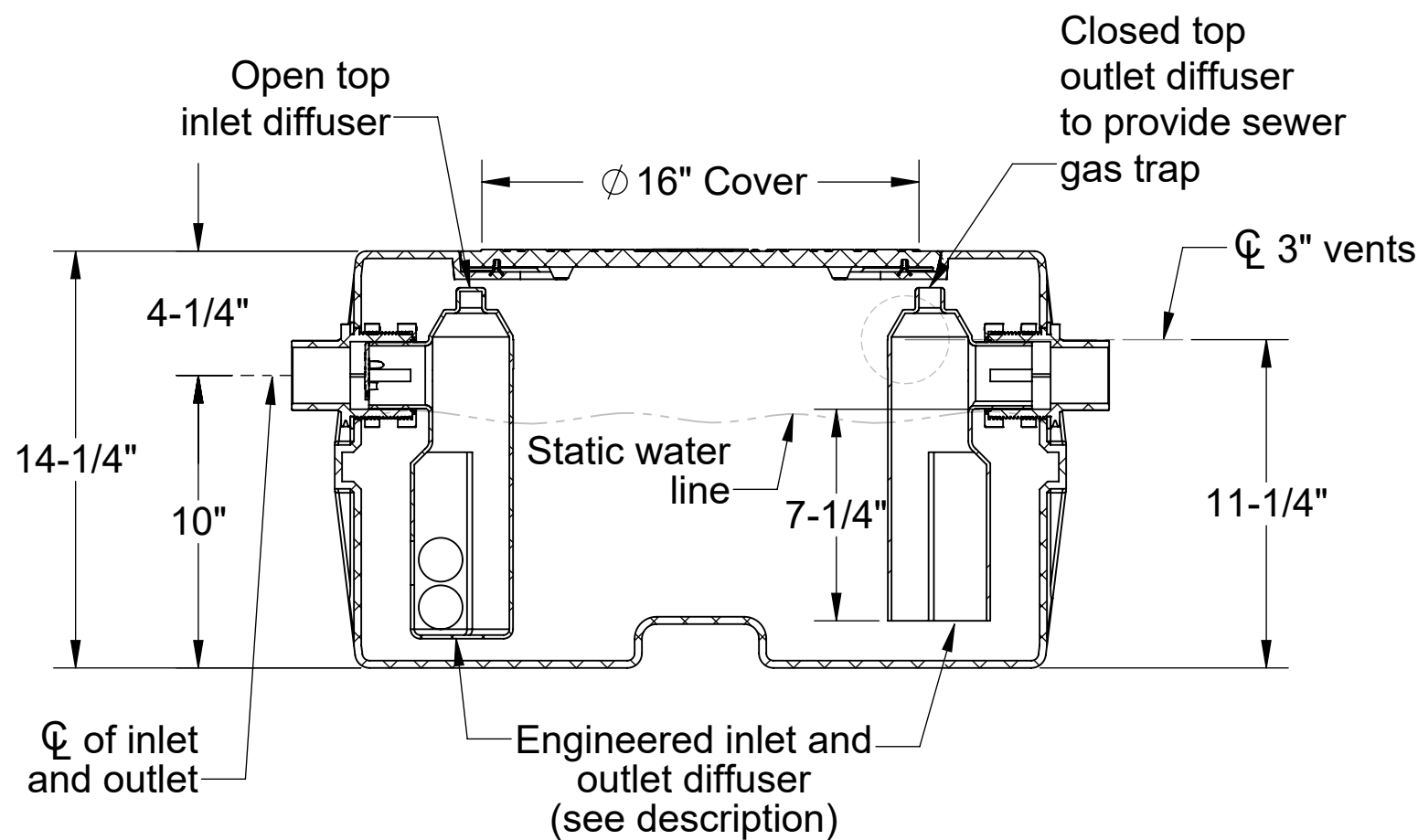

**SECTION "A-A"**

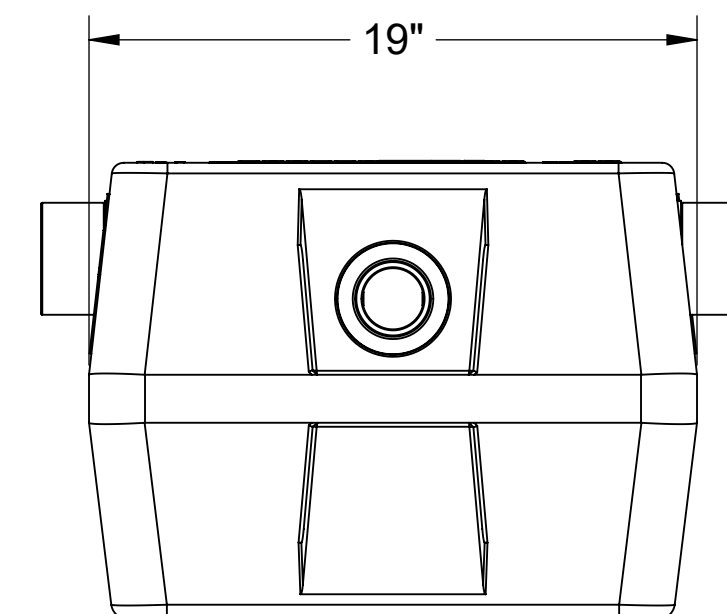

**OUTLET END VIEW**

<b>MODEL NUMBER:</b> OS-15	
<b>DESCRIPTION:</b> 15 GPM POLYETHYLENE OIL/SAND SEPARATOR	
<b>DWG BY:</b> MJ	<b>DATE:</b> 10/02/18
<b>REV:</b> 0	<b>ECO:</b>

**SPECIFICATION SHEET**

**Striem**  
3100 Brinkerhoff  
Kansas City, KS 66115  
Tel: 913-222-1500  
Fax: 913-291-0457  
www.striemco.com



Made in the U.S.A

PROPRIETARY AND CONFIDENTIAL

THE INFORMATION CONTAINED IN THIS DRAWING IS THE SOLE PROPERTY OF STRIEM, LLC. ANY REPRODUCTION IN PART OR AS A WHOLE WITHOUT THE WRITTEN PERMISSION OF STRIEM, LLC. IS PROHIBITED.