

SUBMITTAL SHEET

JOB NAME		ITEM TAG
JOB LOCATION		PART NUMBER
CONTRACTOR	DATE	
ENGINEER APPROVAL	DATE	

CURB STOP

Model T-5200

Above fittings conform to A.W.W.A.
(800-89) (underground service line
Valves and fittings)
300 WOG

Working Pressure, Non Shock (PSI)

Cold working pressure (CWP):
Saturated steam (WSP):

Pictured
Model T-5200



Pictured
Model T-5200
Cut-away

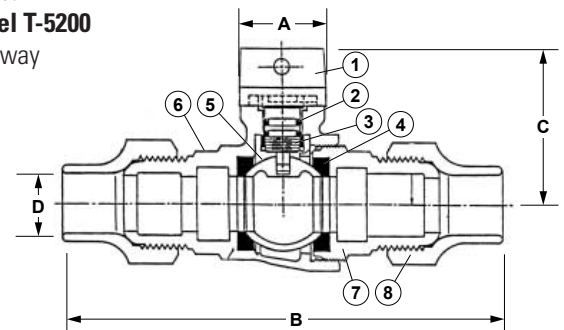

MATERIAL SPECIFICATION

PART	MATERIAL	SPECIFICATION
1	Handle/stem	Bronze
2	O-rings	Buna-n (NBR)
3	Locknut	Bronze
4	Seats	*Teflon
5	Ball	*Teflon coated bronze
6	Body	Bronze
7	End adapter	Bronze
8	Flare	Bronze
*Teflon is a registered trademark of DUPONT		

DIMENSIONS

Size	A	B	C	D
3/4"	1.61	6.95	2.69	0.90
1"	1.61	7.28	2.78	1.17
1-1/4"	1.61	8.28	2.80	1.42
1-1/2"	2.03	9.76	3.46	1.67
2"	2.02	12.50	3.64	2.18