

**CODE NUMBER**

3070065

**DESCRIPTION**

1.28 gpf, XL Sweat Solder Adapter Kit, Polished Chrome Finish, 1.5" Flush Connection, Fixture Connection Top Spud, Single Flush, 1" Inlet, 1" Control Stop, True Mechanical Override, Battery, Infrared, GEM-2® Exposed Sensor Water Closet Flushometer.

**DETAILS**

- Flush Volume: 1.28 gpf (4.8 Lpf)
- Finish: Polished Chrome (CP)
- Power Type: Battery
- Battery Life: 3 years
- Valve: Piston
- Valve Body Material: Semi-red Brass
- Fixture Type: Water Closet
- Fixture Connection: Top Spud
- Rough-In Dimension: 11 ½" (292mm)
- Spud Coupling: 1 ½" (38mm)
- Supply Pipe: 1" (25mm)
- Override: True Mechanical (TMO)
- Control Stop: 1" (1-IN-STOP)
- Inlet: 1"
- Flush Connection: 1.5" (T)
- Adapter: XL Sweat Solder Adapter Kit (XL)

**FEATURES**

- Fixed Volume Piston with Filtered O-ring Bypass
- "Low Battery" Flashing LED
- "User in View" Flashing LED
- No External Volume Adjustment to Ensure Water Conservation
- True Mechanical Override Flush Button
- 72-Hour Sentinel Flush
- Sweat Solder Adapter w/Cover Tube and Cast Wall Flange with Set Screw
- Packing, Stop Seat and Vacuum Breaker Molded from PERMEX® Rubber Compound fChloramine resistance
- Four (4) Size C batteries included
- 1" I.P.S. Screwdriver Bak-Chek® Angle Stop with Free Spinning Vandal Resistant Stop Cap



**COMPLIANCES & CERTIFICATIONS**

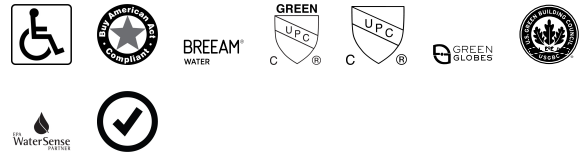

(ADA Compliant, BAA Compliant, BREEAM Water Credit, cUPC Green Certified, cUPC Certified, Green Globes Water Credit, LEED V4 Water Efficiency Credit, WaterSense Listed, Satisfies LEED Credits)

**RECOMMENDED SPECIFICATION**

Valve Body, Cover, Tailpiece and Control Stop shall be in conformance with ASTM Alloy Classification for Semi- Red Brass. Valve shall be in compliance with the applicable sections of ASSE 1037 and ANSI/ASME 112.19.2.

**ELECTRICAL SPECIFICATIONS**

- Arming Delay: 10 seconds
- Battery Life: 3 years
- Sensor Range: 22" - 42" (559 - 1,067mm)

**VALVE OPERATING PRESSURE (FLOWING)**

15-80 PSI (103-552 kPa). Specific fixtures may require greater minimum flowing pressure - consult manufacturer requirements.

**DOWNLOADS**

- [GEM/GEM 2 Piston Type Exposed Installation Instructions](#)
- [EBV-500/550-A Installation Instructions](#)
- [EL-700/750-A Installation Instructions](#)
- [Control Stop Repair and Maintenance Guide](#)
- [Flush Connections Flanges Repair and Maintenance Guide](#)
- [Tail Piece Repair and Maintenance Guide](#)
- [Gem 2 Repair and Maintenance Guide](#)
- [EBV500/EBV550 Repair and Maintenance Guide](#)
- [Additional Downloads](#)

**NOTES**

All information contained within this document subject to change without notice.

Looking for other variations of the GEM-2 111 SFSM product?  
[View the general spec sheet with all options.](#)

[Find a compatible urinal](#) for this flushometer.

[Find a compatible water closet](#) for this flushometer.

WaterSense compliant when used with a WaterSense compliant fixture

Battery life varies according to actual usage and restroom conditions.

**WARRANTY**

[View Warranty Information](#)

**ROUGH-IN**

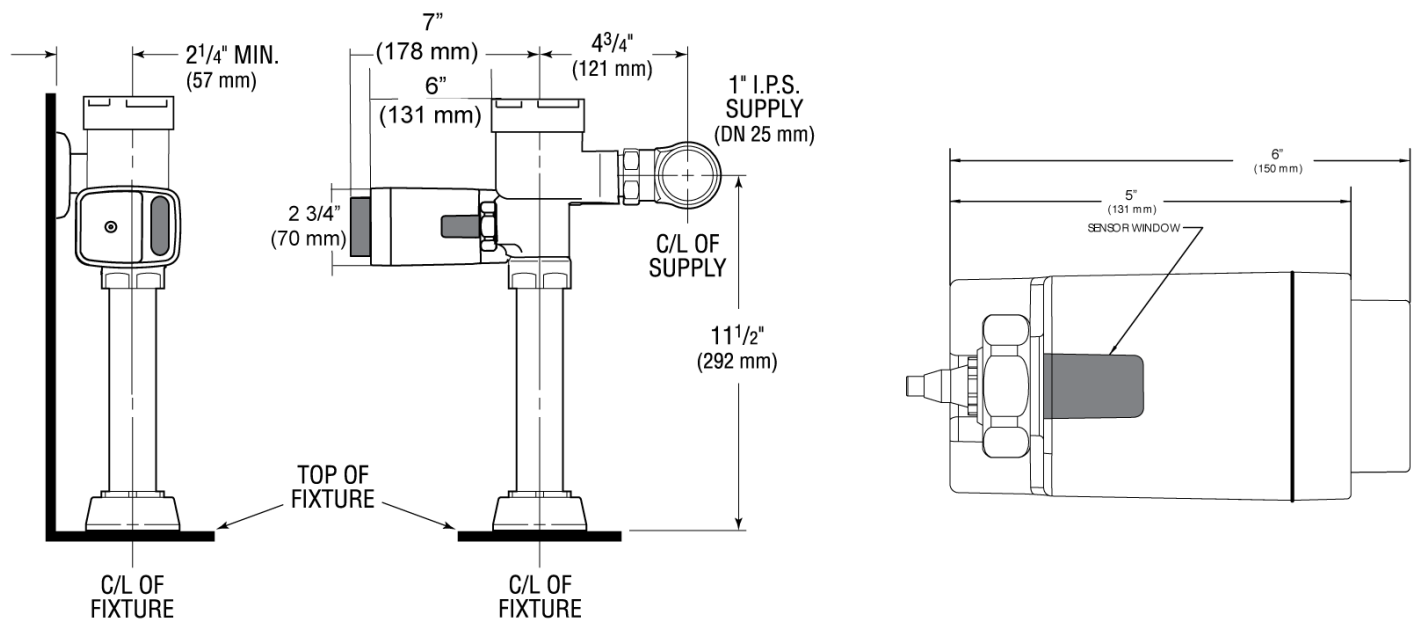

**Sloan 10500 Seymour Ave, Franklin Park, IL 60131**

Phone: 800.982.5839 • Fax: 800.447.8329 • [sloan.com](http://sloan.com)