

Product Specification

D3672LSG/LSGX-Series Omnivore® 2 hp Duplex Grinder Packages

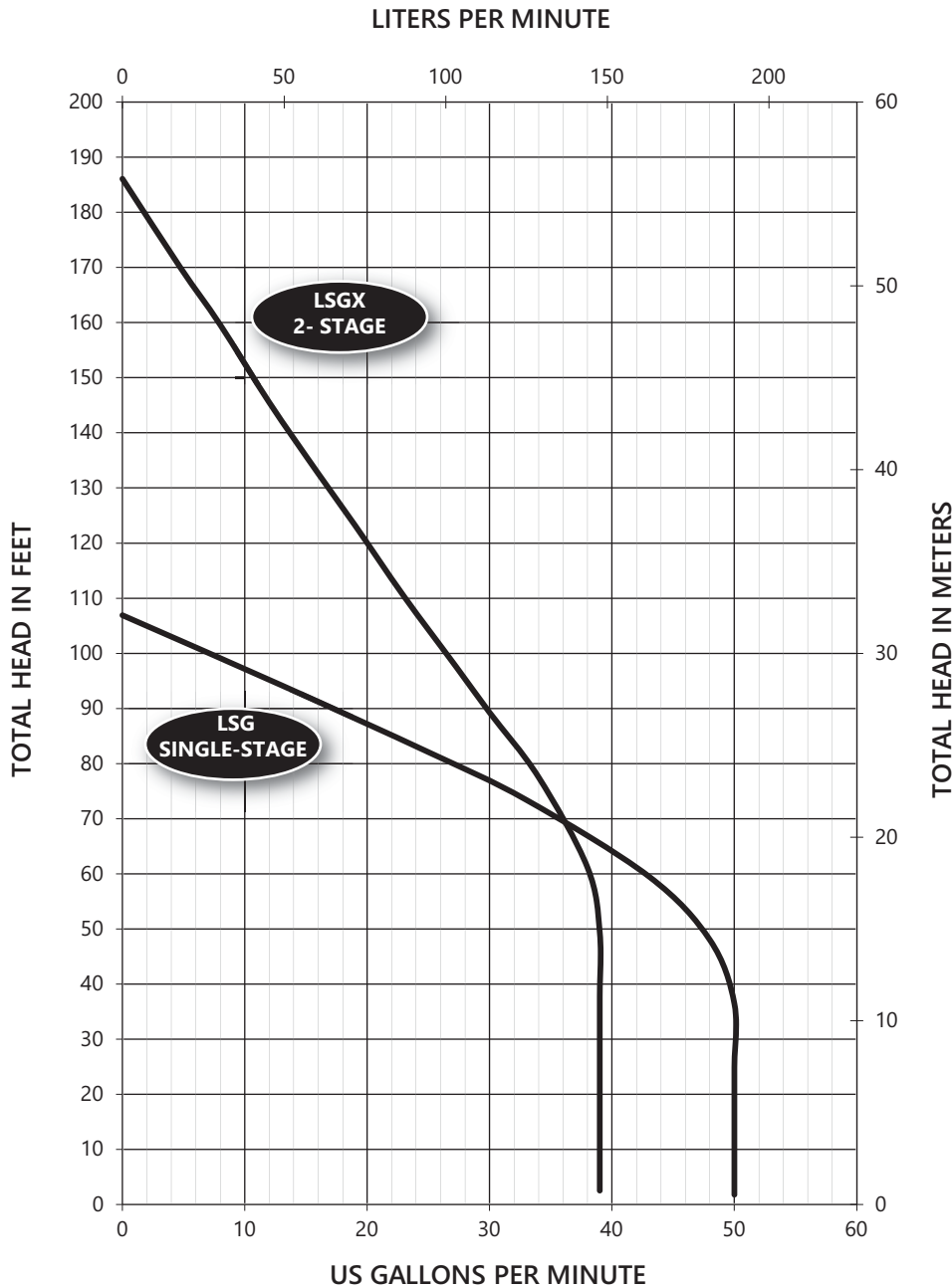
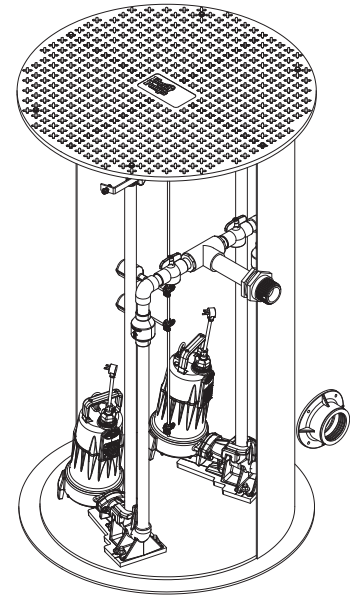

ATTENTION

For pressure sewer applications, verify a **Redundant Check Valve Assembly** (curb stop and check valve) is installed between the pump discharge and the street main, as close to the public right-of-way as possible, on all installations to protect from system pressures.

D3672LSG/LSGX-Series Dimensional Data

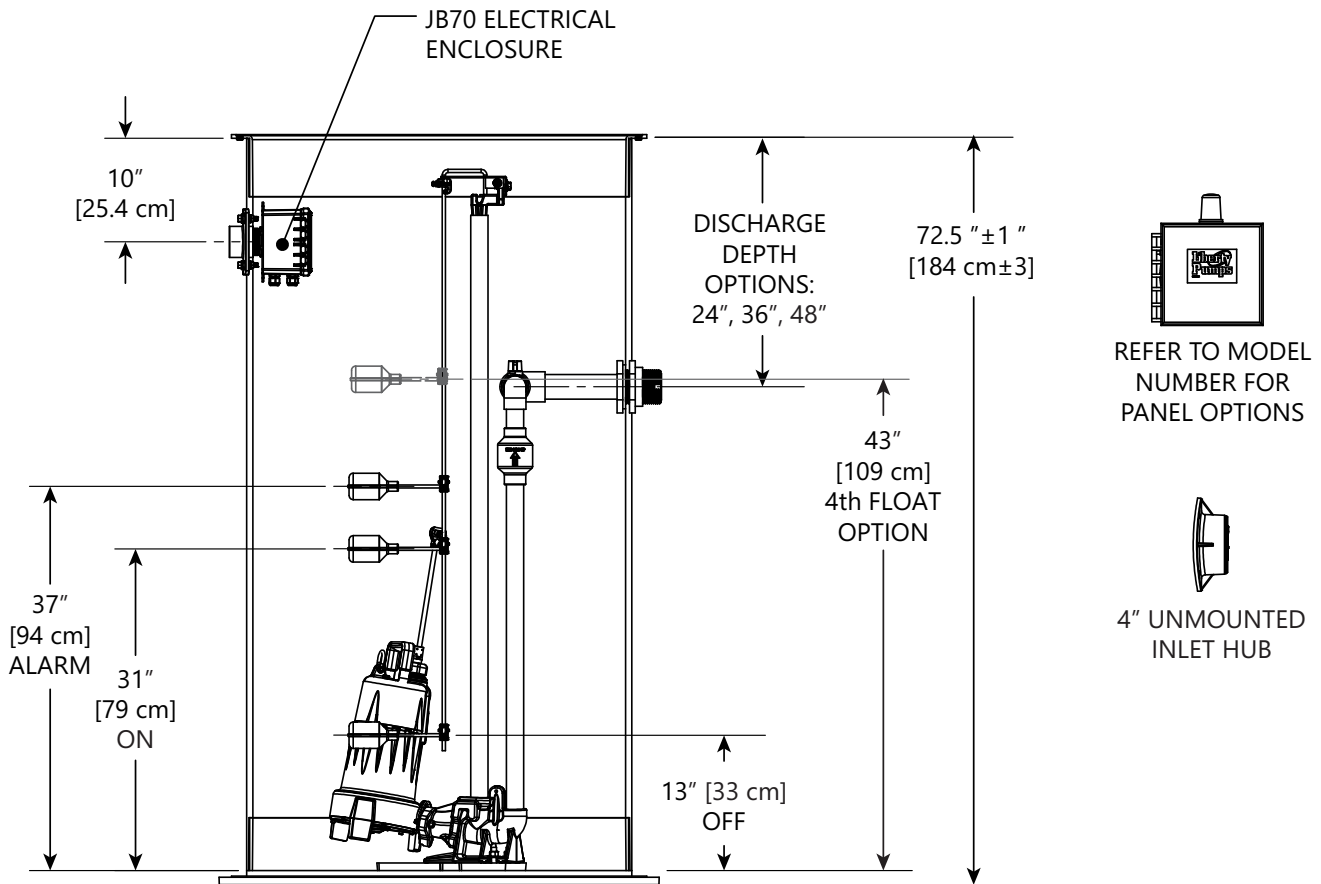
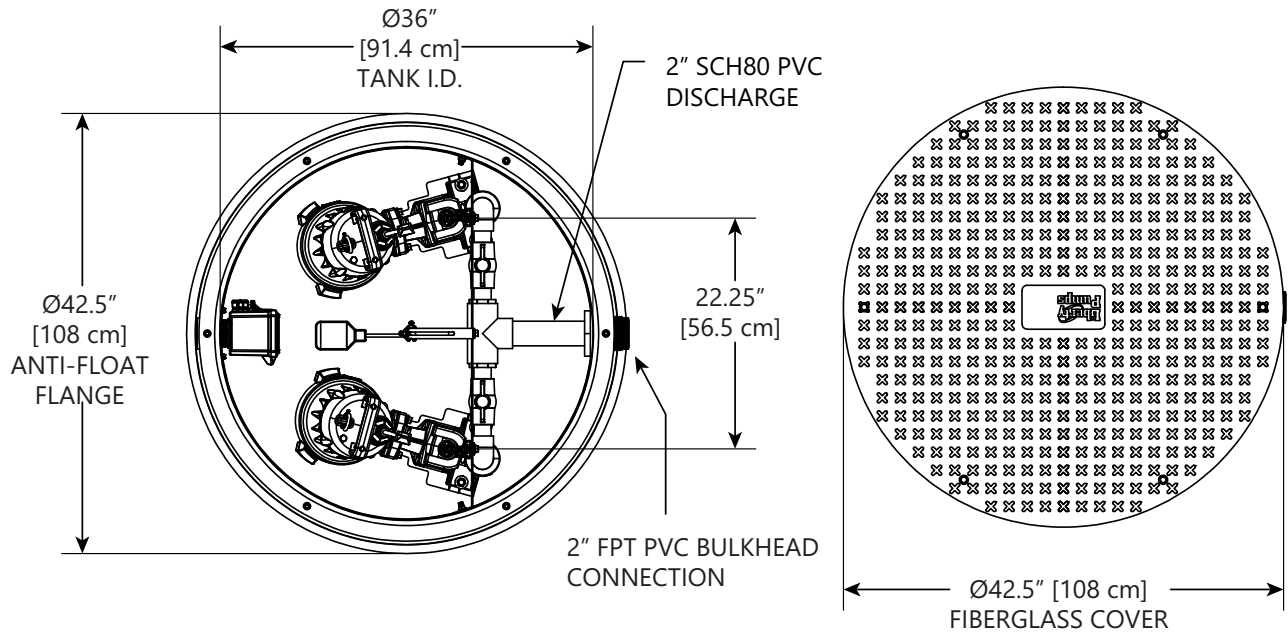

D3672LSG/LSGX-Series Dimensional Data

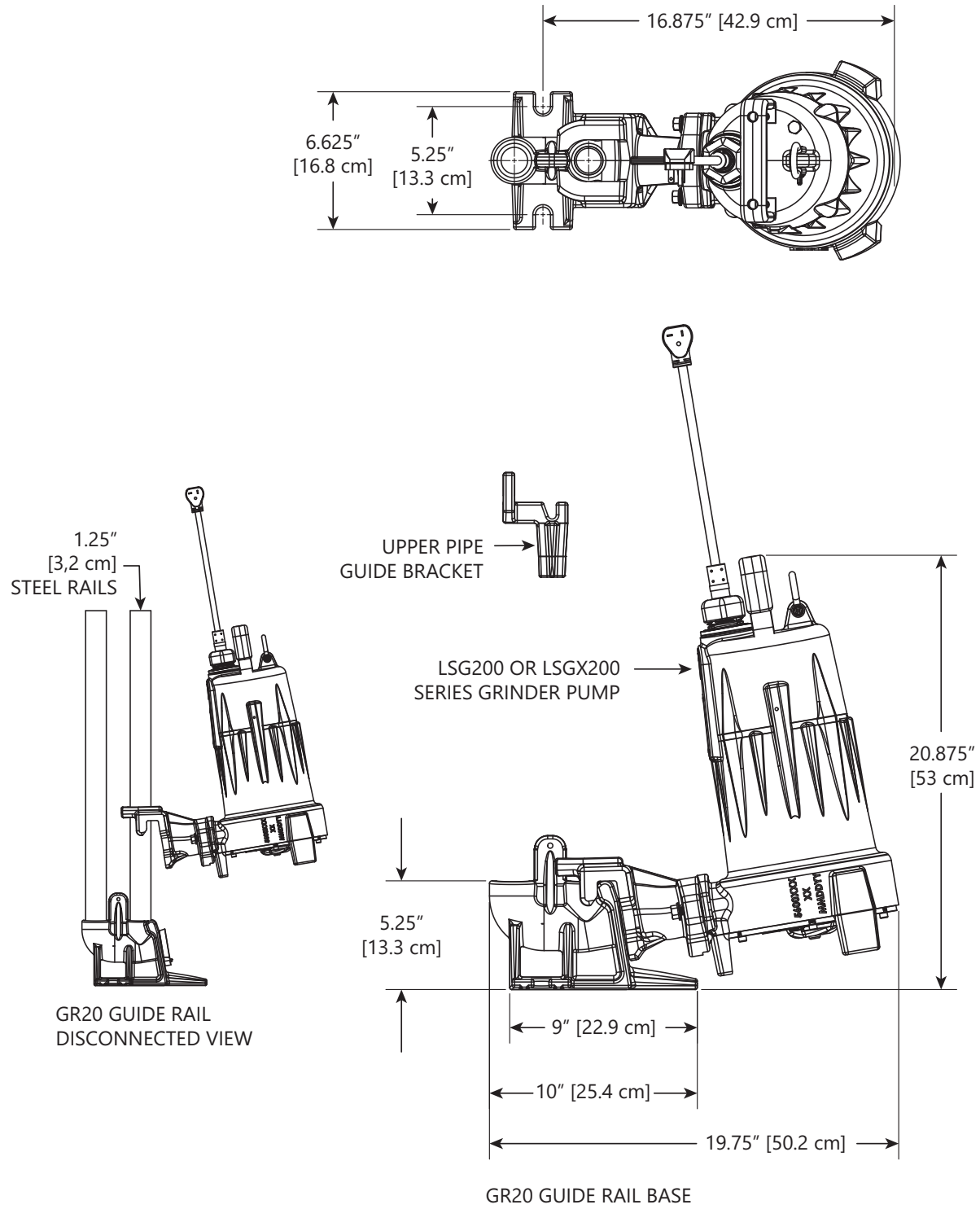

D3672LSG/LSGX-Series Electrical Data

SYSTEM ^{1 2}	HP	RECOMMENDED PANEL POWER FEED					SF	FULL LOAD AMPS ³	LOCKED ROTOR AMPS ³	THERMAL OVERLOAD TEMP	STATOR WINDING CLASS	CORD LENGTH [FT]	PUMP DISCHARGE	STANDARD CONTROL PANEL ⁴
		# LINES	VOLTAGE	PHASE	AMPS	FEED								
D3672LSG202	2	2	208/230	1	30	PUMP	1.0	15	53	105°C	B	25	1-1/4" NPT	AE24H=3
		1	115	1	15	CONTROL								
D3672LSG202-C	2	2	208/230	1	30	PUMP	1.0	15	53	135°C	B	35	1-1/4" NPT	AE24HC=3-3
		1	115	1	15	CONTROL								
D3672LSG203	2	1	208/230	3	30	BOTH	1.0	10.6	61	N/A	B	25	1-1/4" NPT	AE34=3-511
D3672LSG204	2	1	440-480	3	20	BOTH	1.0	5.3	31	N/A	B	25	1-1/4" NPT	AE34=3-171
D3672LSG205	2	1	575	3	20	BOTH	1.0	4.9	31	N/A	B	25	1-1/4" NPT	AE54=3-161
D3672LSGX202	2	2	208-230	1	30	PUMP	1.0	15	53	135°C	B	25	1-1/4" NPT	AE24H=3
		1	115	1	15	CONTROL								
D3672LSGX202-C	2	2	208-230	1	30	PUMP	1.0	15	53	135°C	B	35	1-1/4" NPT	AE24HC=3-3
		1	115	1	15	CONTROL								
D3672LSGX203	2	1	208/230	3	30	BOTH	1.0	10.6	61	N/A	B	25	1-1/4" NPT	AE34=3-511
D3672LSGX204	2	1	440-480	3	20	BOTH	1.0	5.3	31	N/A	B	25	1-1/4" NPT	AE34=3-171
D3672LSGX205	2	1	575	3	20	BOTH	1.0	4.9	31	N/A	B	25	1-1/4" NPT	AE54=3-161

- 1 Add -IP to the model number for IP-Series™ panel upgrade.
- 2 Add -4F to the model number for **four float** panel option.
- 3 Amperage values are for each pump.
- 4 Electrical service shall be sized to support all pumps running simultaneously.

D3672LSG/LSGX-Series Technical Data

SYSTEM	TANK	WOUND FIBERGLASS WITH ANTI-FLOTATION FLANGE STANDARD – FIBERGLASS COVER OPTIONAL – STEEL COVER
	CAPACITY	TOTAL BASIN VOLUME - 317 GALLON / 1200 LITERS PUMP CYCLE - 88 GALLONS / 333 LITERS
	GUIDE RAIL	STANDARD – SCHEDULE 40 GALVANIZED OPTIONAL – SCHEDULE 40 STAINLESS STEEL
	GUIDE RAIL BASE/DISCONNECT (GR20)	CAST IRON
	INLET HUB	4" WITH FLANGE GASKET AND PIPE SEAL
	DISCHARGE PIPING	2" SCHEDULE 80 PVC
	CONTROL PANEL	NEMA 4X DUPLEX OUTDOOR ALTERNATING PANEL WITH AUDIBLE (80 dBi) AND VISUAL HIGH WATER ALARM
	WEIGHT	526 LBS / 239 KG
PUMP	IMPELLER	300 SERIES STAINLESS STEEL
	PAINT	POWDER COAT
	MAX LIQUID TEMP	60°C / 140°F
	MAX STATOR TEMP (1-PHASE)	LSG202 – 105°C / 221°F LSG202-C AND LSGX MODELS – 135°C / 275°F
	THERMAL OVERLOAD (1-PHASE)	LSG202 – 105°C / 221°F LSG202-C AND LSGX MODELS – 135°C / 275°F
	POWER CORD TYPE	SJOOW (1-PHASE) SEOOW (3-PHASE) SOOW (EXTERNAL CAPACITOR MODELS)
	MOTOR HOUSING	CLASS 25 CAST IRON
	VOLUTE	CLASS 25 CAST IRON
	SHAFT	300 SERIES STAINLESS STEEL
	HARDWARE	STAINLESS
	O-RINGS	BUNA-N
	MECHANICAL SEAL	UNITIZED GRAPHITE IMPREGNATED SILICON CARBIDE
	MIN BEARING LIFE	50,000 HRS
	CERTIFICATIONS	SSPMA, cCSAus

D3672LSG/LSGX-Series Specifications

1.01 GENERAL

The contractor shall provide labor, material, equipment, and incidentals required to provide _____ (QTY) centrifugal grinder pumps as specified herein. The pump models covered in this specification are LSG/LSGX-Series single/three-phase grinder pumps. The pump furnished for this application shall be model _____ as manufactured by Liberty Pumps.

2.01 OPERATING CONDITIONS

Each submersible pump shall be rated at 2 hp, _____ volts, _____ phase, 60 Hz, 3450 RPM. The unit shall produce _____ GPM at _____ feet of total dynamic head.

The submersible pump shall be capable of handling residential and commercial sewage and grinding it to a fine slurry enabling it to be pumped over long distances in pipelines as small as 1.25" in diameter. The LSG-Series single-stage submersible pump shall have a shut-off head of 110 feet and a maximum flow of 50 GPM @ 10 feet of total dynamic head. The LSGX-Series 2-stage submersible pump shall have a shut-off head of 185 feet and a maximum flow of 38 GPM @ 10 feet of total dynamic head.

3.01 CONSTRUCTION

Each centrifugal grinder pump shall be equal to the  Certified LSG/LSGX-Series grinder pumps as manufactured by Liberty Pumps, Bergen NY. The castings shall be constructed of class 25 cast iron. The motor housing shall be oil-filled to dissipate heat. Air-filled motors shall not be considered equal since they do not properly dissipate heat from the motor. All mating parts shall be machined and sealed with a Buna-N O-ring. All fasteners exposed to the liquid shall be stainless steel. The motor shall be protected on the top side with sealed cord entry plate with molded pins to conduct electricity eliminating the ability of water to enter internally through the cord. The motor shall be protected on the lower side with a dual seal arrangement. The first seal is a double lip seal molded in fluoroelastomer or Buna-N. The second/main seal shall be a unitized graphite impregnated silicon carbide hard face with stainless steel housings and spring.

The upper and lower bearing shall be capable of handling all radial thrust loads. The lower bearing shall have the additional ability to handle the downward axial thrust produced by the impeller and cutters by design of angular contact roller races. The pump housing shall be of the concentric design thereby equalizing the pressure forces inside the housing which will extend the service life of the seals and bearings. Additionally there shall be no cutwater in the housing volute in order to discourage the entrapment of flowing debris. The pump shall be furnished with a stainless steel handle having a nitrile grip.

4.01 ELECTRICAL POWER CORD

The submersible pumps shall be supplied with 25 feet of multi-conductor power cord (35 feet for external capacitor models). It shall be cord type SJOOW (1-phase), SEOOW (3-phase), or SOOW (external capacitor models), capable of continued exposure to the pumped liquid. The power cord shall be sized for the rated full load amps of the pump in accordance with the National Electric Code. The power cord shall not enter the motor housing directly but will conduct electricity to the motor by means of a watertight compression fitting cord plate assembly with molded pins to conduct electricity. This will eliminate the ability of water to enter internally through the cord via a damaged or wicking cord.

5.01 MOTORS

All motors shall be oil-filled and class B insulated NEMA B design rated for continuous duty. Since air-filled motors are not capable of dissipating heat as effectively, they shall not be considered equal. Single-phase motors shall be capacitor start/capacitor run and have an integral thermal overload switch in the windings for protecting the motor.

6.01 BEARINGS AND SHAFT

An upper radial and a lower angular contact ball bearing shall be required. The upper bearing shall be a single ball/race type bearing. The lower bearing shall be an angular contact heavy-duty ball/race type bearing, designed to handle axial grinder pump thrust loads. Both bearings shall be permanently lubricated by the oil, which fills the motor housing. The bearing system shall be designed to enable proper cutter alignment from shut off head to maximum load at 10 feet of TDH. The motor shaft shall be made of 300 series stainless steel and have a minimum diameter of 0.670".

7.01 SEALS

The pumps shall have a dual seal arrangement consisting of a lower and upper seal to protect the motor from the pumping liquid. The lower seal shall be fluoroelastomer OR Buna-N molded double lip seal, designed to exclude foreign material away from the main upper seal. The upper seal shall be a unitized graphite impregnated silicon carbide hard face seal with stainless steel housings and spring equal to Crane Type 6A. The motor plate/housing interface shall be sealed with a Buna-N O-ring.

8.01 IMPELLER

The impeller shall be an investment cast stainless steel impeller with pump out vanes on the back shroud to keep debris away from the seal area. It shall be keyed and bolted to the motor shaft.

9.01 CUTTER MECHANISM

The cutter and plate shall consist of 440 stainless steel with a Rockwell C hardness of 55–60. The stationary cutter plate shall have specially designed orifices through it, which enable the slurry to flow through the pump housing at an equalized pressure and velocity. The stationary cutter shall consist of V shapes to maximize cutting action and arc shape exclusion slots to outwardly eject debris from under the rotary cutter. The rotary cutter shall have (4) blades and be designed with a recessed area behind the cutting edge to prevent the accumulation and binding of any material between rotary cutter and the stationary cutter. The cutting system must incorporate close tolerances for optimum performance. Ring or radial cutters, or those that grind on the outside circumference, shall not be considered equal.

10.01 PRESSURE SEWER APPLICATIONS

A redundant check valve assembly consisting of a curb stop and check valve must be installed between the pump discharge and the street main, as close to the public right-of-way as possible, on all pressure (force main) sewer installations to protect from system pressures. The curb stop valve is necessary to isolate the site from the pressure sewer while the check valve provides redundant protection against potentially detrimental backflow. All valves and fittings should be rated for at least 200 PSI service. See Liberty Pumps line of CSV-Series Curb Stop/Swing Check Valve Assemblies and CK-Series Connection Kit.

11.01 CONTROLS

The pumps shall be controlled with a NEMA 4X outdoor duplex control panel with three or four float switches including a high water alarm or with optional IP Series NEMA 4X outdoor duplex control panel with transducer, adjustable setpoints, data logging, and a high water alarm.

12.01 PAINT

The exterior of the casting shall be protected with powder coat paint.

13.01 SUPPORT

The pumps shall have cast iron support legs enabling it to be a freestanding unit. The legs will be high enough to allow solids and long stringy debris to enter the cutter assembly.

14.01 SERVICEABILITY

Components required for the repair of the pump shall be shipped within a period of 24 hours.

15.01 FACTORY ASSEMBLED TANK SYSTEMS WITH GUIDE RAIL AND QUICK DISCONNECT DISCHARGE

Factory mounted guide rail system with pump suspended by means of bolt-on quick disconnect that is sealed by means of nitrile grommets. The discharge piping shall be schedule 80 PVC and furnished with a check valve and PVC shut-off ball valve. The tank shall be wound fiberglass. An inlet hub shall be provided with the system.

16.01 TESTING

The pump shall have a ground continuity check and the motor chamber shall be hi-potted to test for electrical integrity, moisture content and insulation defects. The motor and volute housing shall be pressurized, and an air leak decay test performed to ensure integrity of the motor housing. The pump shall be monitored for run voltage and current, and checked for noise or other malfunction.

17.01 QUALITY CONTROL

The pumps shall be manufactured in an ISO 9001 certified facility.

18.01 WARRANTY

Standard limited warranty shall be 3 years.