



Airzone dampers technical data sheet

Table of contents

1. DIMENSIONS AND TECHNICAL SPECIFICATIONS.....	3
2. FLOW CONTROL DEVICE.....	4
3. PROPORTIONAL CONTROL.....	5
4. PRESSURE DROP IN THE DAMPER.....	6
4.1. Totally opened.....	6
4.2. Partially opened.....	7
5. MAINTENANCE.....	7

1. DIMENSIONS AND TECHNICAL SPECIFICATIONS

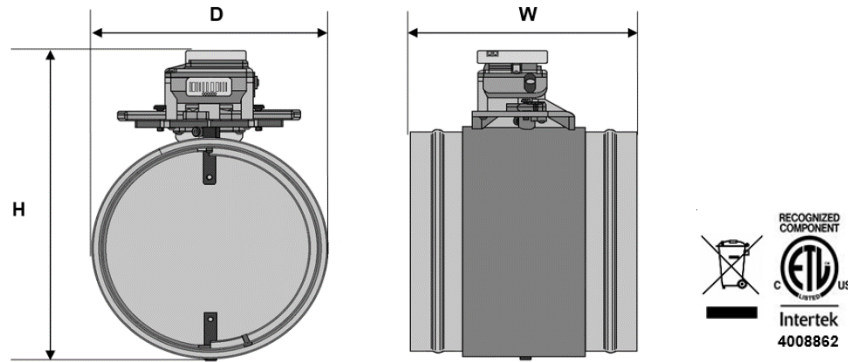

Diameter	6"	8"	10"
Dimensions (WxHxD)	8.3x11.5x6.5 inches	8.3x13.5x8.1 inches	11.2x15.4x10 inches
	(210x292x165 mm)	(210x342x205 mm)	(285x392x255 mm)
Weight (Mass)	1.66 lb (0.755 kg)	2.17 lb (0.986 kg)	4.32 lb (1.961 kg)

Diameter	12"	14"
Dimensions (WxHxD)	15.3x12x16,5 inches	17.3x14x18.5 inches
	(388x305x419 mm)	(438x356x470 mm)
Weight (Mass)	7.05 lb (3.2 kg)	9.92 lb (4.5 kg)

2. FLOW CONTROL DEVICE

The Airzone motorized round damper includes an airflow-control device that allows to manually set the maximum opening and closing of the damper. By means of this adjustment, the damper can be set to always supply a minimum air and/or to make a more accurate balancing of the airflows in the different zones.

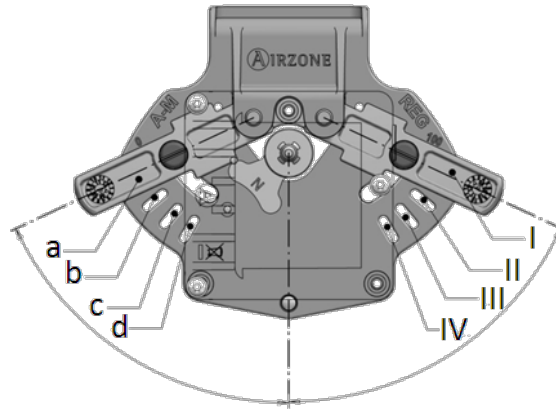

Minimum air (A–M)

If utilized, the device, depending on its setting, avoids the total closing of the damper in four steps (a-b-c-d) for minimum-fresh air purposes. By default, it is positioned in “a”, to change this setting, the damper has to be opened.

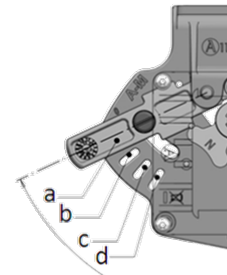

Balancing (REG)

If utilized, the device, depending on its setting, avoids the total opening of the damper in four steps (I-II-III-IV) for air balancing purposes. By default, it is positioned in “I”, to change this setting, the damper has to be closed.

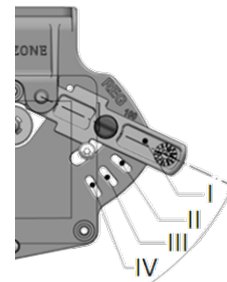

The below graphic shows the total airflow rate depending on the setting of the two airflow balancing devices.

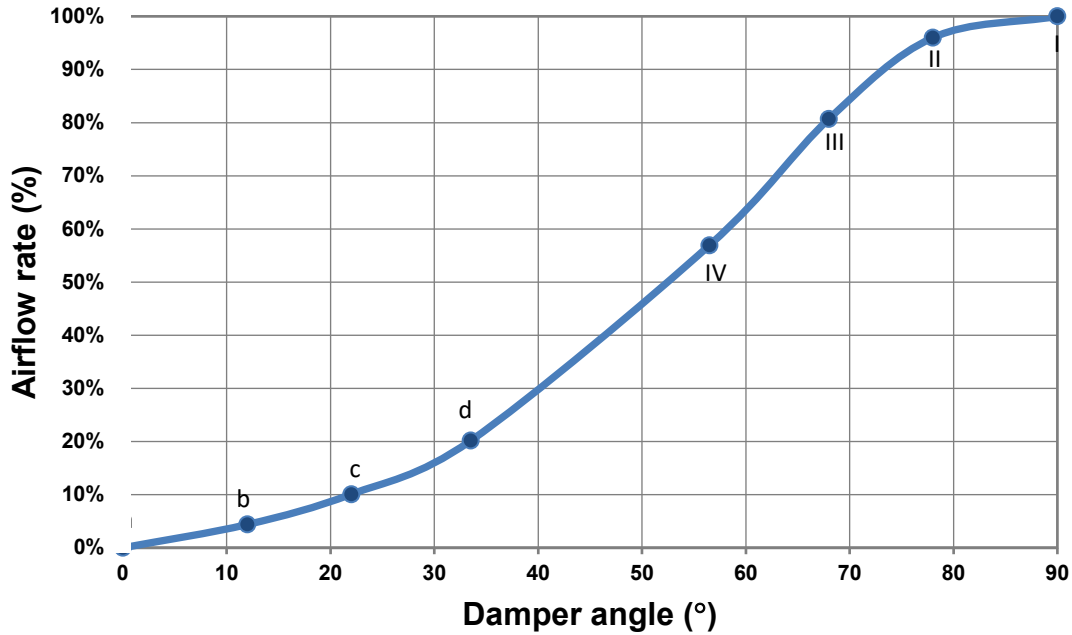

3. PROPORTIONAL CONTROL

By default, the operation of the damper is proportional in four steps. As bigger the gap between the setpoint temperature and the room temperature is, the more opened the damper will be. This behavior is shown in the graphic below:

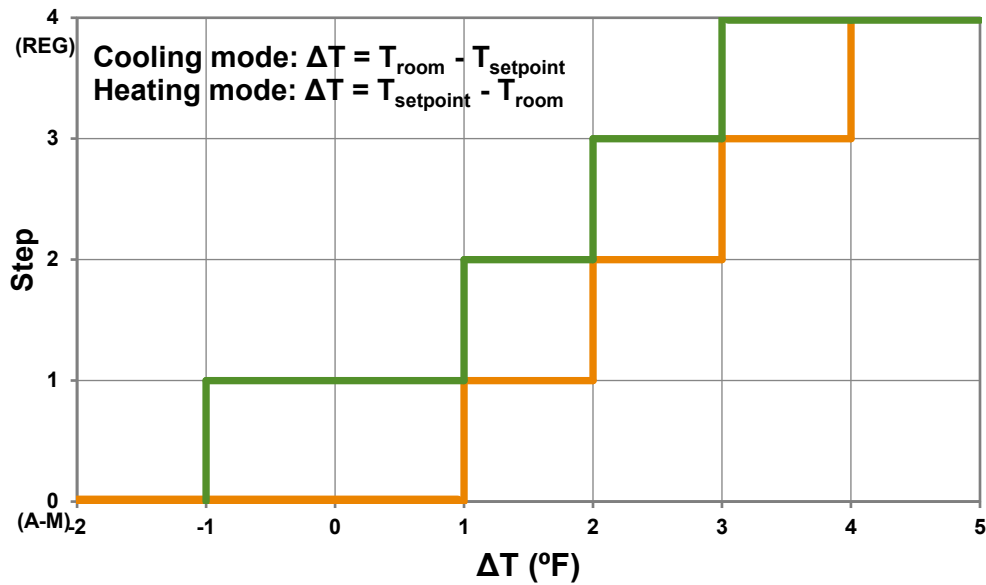

4. PRESSURE DROP IN THE DAMPER

4.1. Totally opened

The pressure drop in a totally opened damper is shown below:

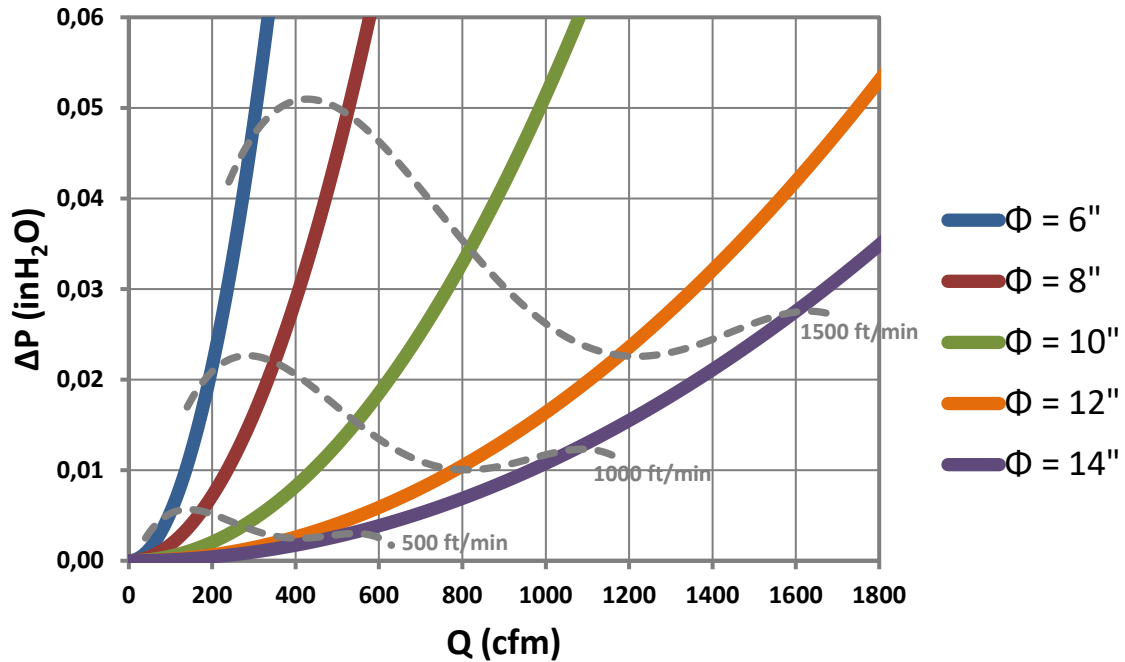

	v (ft/min)	500	1000	1500
Φ = 6"	Q(CFM)	98.17	196.35	294.52
	ΔP(inH ₂ O)	0.0052	0.0207	0.0467
Φ = 8"	Q(CFM)	174.53	349.06	523.59
	ΔP(inH ₂ O)	0.0055	0.0219	0.0493
Φ = 10"	Q(CFM)	272.70	545.41	818.12
	ΔP(inH ₂ O)	0.0038	0.0153	0.0344
Φ = 12"	Q(CFM)	392.70	785.40	1178.10
	ΔP(inH ₂ O)	0.0025	0.0101	0.0227
Φ = 14"	Q(CFM)	534.50	1069.00	1603.50
	ΔP(inH ₂ O)	0.0031	0.0123	0.0277

4.2. Partially opened

The pressure drop with the damper in a setting different from the totally opened ($REG \neq I$) is calculated as follows:

$$\Delta P_{REG} = k_{REG} \cdot \Delta P_{REG=I}$$

Where:

- ΔP_{REG} is the pressure drop in the *REG*. setting.
- $\Delta P_{REG=I}$ is the pressure drop in the *REG=I* setting.
- k_{REG} is the correction factor depending in the *REG* setting which values are shown below.

<i>REG</i>	I	II	III	IV
α	90°	78°	68°	56.5
k_{REG}	1	1.4	3.9	9.6

5. MAINTENANCE

In case of failure, the damper actuator can be replaced as shown below. Just one screw has to be unscrew. It is recommended to use a 12"x12" (minimum) ceiling access panel.

