

Liberty Pumps®

Pro370-Series

*with
QuickTree®
Technology*

*The most advanced
residential sewage
package available*

Features:

- Separate access cover
- QuickTree® float system. Allows easy removal of floats without pulling the pump.
- Large 41 gallon capacity
 - Anti-flotation collar
 - Molded torque-stops
- Integrally molded handles
- Unique integrated cord seal technology
- Integral rubber cover seals

*Shipped with
Clear Construction Cover*



Clear disposable cover protects the system during masonry work and rough-in.



3
Year Warranty

Patent: See
www.libertypumps.com/patents

innovate. evolve.

Pro370

QuickTree® Technology

Features:

- QuickTree® system allows easy access and removal of switches without disturbing pump or plumbing.
- Integral rubber seals permanently attached to cover.
- Unique cord seal technology.
- Inspection/Access cover.
- Larger basin – 40% more capacity than standard 18" X 30" basins – decreases switch cycles, improves pump life.
- Integrally molded torque stops secure the pump in its proper position.
- Integrally molded anti-flotation collar.
- Integrally molded handles to ease transportation and installation.
- Durable polyethylene construction with radial ribs for added strength.
- Completely assembled.
- Available with any of Liberty's 2" solids-handling sewage pumps.

QuickTree® Technology

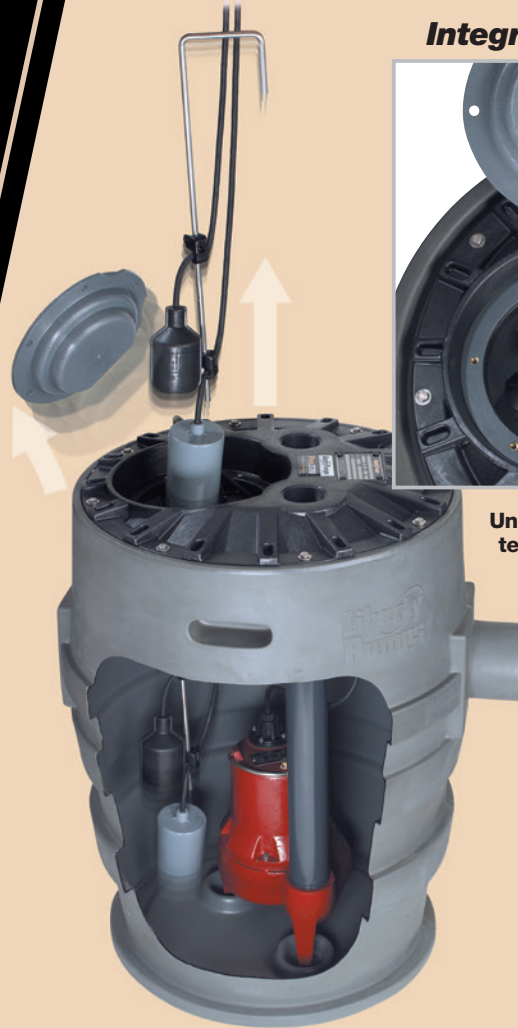

Integral Rubber Seals



Unique integrated cord seal technology and permanent rubber cover gaskets.

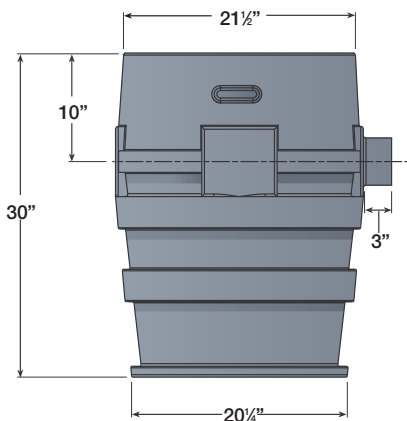

Specifications: 2" Discharge Systems

MODEL	HP	VOLTS	PHASE	DISCHARGE	WGT. LBS.
P372LE41	4/10	115	1	2"	60
P372LE51	1/2	115	1	2"	64
P372LE52	1/2	208-230	1	2"	63
P372LE71	3/4	115	1	2"	83
P372LE72	3/4	208-230	1	2"	83
P372LE102*	1	208-230	1	2"	86
P372LEH102*	1	208-230	1	2"	86

For 3" discharge systems change model number from "372" to "373."
EXAMPLE: P373LE41

See specific LE-Series literature for complete pump performance and specifications.
* High head applications only. Consult factory for proper pump sizing.



Certified Pumps

inno

Pro370-Series 21" x 30" – 41 Gallons

New integrated cord seal technology

Stainless steel cover bolts

Separate inspection cover allows access to switches

Integral rubber gaskets permanently attached to covers

41 gallon capacity for longer pump cycles

Integral handles

Integrally molded no-hub type inlet, 4"

QuickTree® removable float system allows easy access to switch – separate from pump. Stainless steel rod.

Schedule 80 PVC discharge pipe

Molded anti-float collar

Integrally molded "torque-stops" for pump security

Patent: See www.libertypumps.com/patents

P370XL Series - IAPMO Listed

The P370XL systems are specifically designed to pass a 10' stack test and are IAPMO listed.

The P370XL-Series has all the same features as the standard P370 except for a 16 bolt cover.

To order, simply add "X" to any standard P370 system.
Example:
P372XLE41



QuickTree® Kit

Installed your Pro370 empty? Simply order a QuickTree® Kit and manual LE-Series pump.

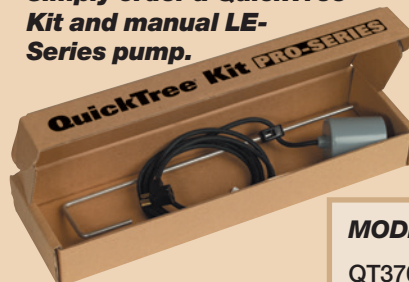

QuickTree® Kit comes complete with stainless steel rod, pump float and clamps pre-mounted.

Need to install a Liberty pump in an empty Pro370 basin? ...No-Problem! QuickTree® Kits make addition of a pump easy! Simply install a manual LE-Series pump and a matching QuickTree® Kit. Kits include stainless steel float tree, pre-mounted pump float and additional clamp for an alarm float. Simply hang the QuickTree® from its holder underneath the access cover and you're ready to go.

MODEL

DESCRIPTION

QT370-115-10	QuickTree® for PRO370, 115V, 10' cord
QT370-115-25	QuickTree® for PRO370, 115V, 25' cord
QT370-230-10	QuickTree® for PRO370, 230V, 10' cord
QT370-230-25	QuickTree® for PRO370, 230V, 25' cord

Riser allows burial of the Pro370 System up to a maximum depth of 18" below grade.

A convenient chamber for all your pump's electrical and piping connections – out of sight and below grade. Riser simply slides over the sealed 370 system. Cover is retained by 4 stainless steel bolts and features a twist-lock design with provision for padlock to deter unwanted entry.

Specifications:

Weight: 28 lbs. - (Riser and Cover)

Riser Height: 18-3/4"

Total Height with Cover: 20-1/2"

Diameter: 32"

Optional Access Riser

Fits Pro370 and Pro380-Series systems



Top View

MODEL	DESCRIPTION
AR18	Access Riser
AC18	Access Riser Cover (Environmental Green)
ARC18	Kit, Access Riser with Cover
ARCKIT115	Kit, Access Riser with Cover and 2" installation accessories - 115V
ARCKIT230	Kit, Access Riser with Cover and 2" installation accessories - 230V
IKIT2-115	Installation Kit 2", 115V
IKIT2-230	Installation Kit 2", 230V

Liberty's installation kits provide all the components for a professional installation inside the riser. Kit includes: JB-Series wiring box and hardware, check valve with a disconnect union feature, coupling and elbows (PVC piping not included). Kits available in 2" discharge and vent size only.

Pro370-Series Alarmed System



ALM-2W
Outdoor Rated
115 volt Alarm
(not shown)

ALM-2 (pictured)
Indoor 115V Alarm
with 9 volt Battery
Back-up

Now, have the assurance of early warning in the event of a high-level condition with an alarm option installed from the factory! We do the work for you by mounting the alarm float in the basin at its proper level – no need to even open the cover! Simply mount the alarm panel in its desired location, supply power and connect the alarm float leads! Offered with three different alarm options for indoor or outdoor applications.

How to Order:

Alarm Model	Add Suffix	Ordering Example
ALM-2	/A2	P372LE41/A2
ALM-2W	/A2W	P372LE41/A2W
ALM-2-1	/A21	P372LE41/A21

Alarm float is pre-set at proper level in basin.
Alarm panel packaged with unit.



Liberty Pumps • 7000 Apple Tree Avenue • Bergen, New York 14416
Phone 800-543-2550 Fax (585) 494-1839

WWW.
libertypumps
.com