

88 Section Assembly

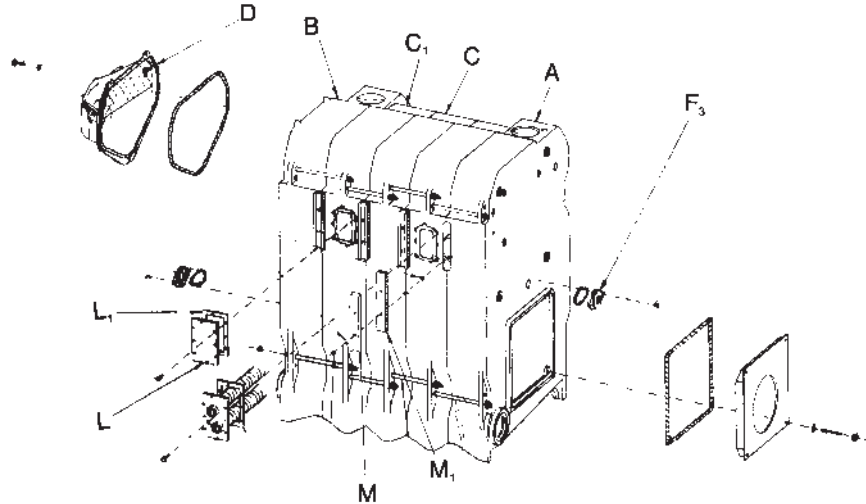

Fig. No.	Part No.	Description	Notes
	316-301-154	Front Section – 8813 – 80 P. S. I.	
B	316-301-174	Back Section – 8818 – 80 P. S. I.	■
C	316-301-164	Regular Intermediate Section – 8815 – 80 P. S. I.	■
C1	316-301-169	Tankless Intermediate Section – 8816 – P. S. I.	■
	316-301-159	Supply Intermediate Section w/ 5" N.P.T. Supply Outlet Tapping – 8814 – 80 P. S. I.	■
	386-300-213	86/88 Section Replacement Kit (Incl. rope, seals, sealant, rope adhesive)	
	560-134-495	5/8" x 11" Draw Rod w/o Nut (4 per joint) Int. to Int.	
	560-134-505	5/8" x 13" Draw Rod w/o Nut (4 per joint), Frt. or Bk. to Int.	
	561-928-224	5/8-11 Nut Hex (2 per draw rod)	
	562-248-710	5/8" Washer (1 per draw rod)	
	590-735-140	1/2" Dia. Sealing Rope type HD-500 (13' per joint, 7" for burner plate, 6' for collar)	
	590-735-145	1/8" Dia. Wick (1 for damper locking plate) Type FNS 125	
	590-735-150	3/8" Dia. Sealing Rope (1' per observation port) Type MD-375	
	591-638-851	Silicone Sealant RTV700, 3 oz.	
	591-641-850	Construction Adhesive for Sealing Rope, 11 oz.	
	591-706-214	Flue Brush, 123 DMG	■
	592-800-005	Square Cut Seal, 9" (1 per joint)	
	592-800-007	Square Cut Seal, 6" (1 per joint)	
D	340-004-606	Flue Collar Assembly, 10" (Includes Flue Collar, Damper, Damper Quadrant, Locking Plate, Swivel and Brackets) (488-688)	
D	340-004-607	Flue Collar Assembly, 12" (Includes Flue Collar, Damper, Damper Quadrant, Locking Plate, Swivel and Brackets) (788-888)	
D	340-004-608	Flue Collar Assembly, 14" (Includes Flue Collar, Damper, Damper Quadrant, Locking Plate, Swivel and Brackets) (988-1388)	
D	340-004-609	Flue Collar Assembly, 16" (Includes Flue Collar, Damper, Damper Quadrant, Locking Plate, Swivel and Brackets) (1488-1688)	
D	340-004-612	Flue Collar Assembly, 18" (Includes Flue Collar, Damper, Damper Quadrant, Locking Plate, Swivel and Brackets) (1788-1888)	
	330-056-634	Quadrant for Flue Collar	
	460-003-646	Damper Blade for Flue Collar	
	563-530-784	Damper Locking Plate for Flue Collar	
F3	385-600-099	Observation Port Assembly (Includes Frame, Sealing Rope, Plugs and Sight Glass)	
	590-317-580	Washer for Sight Glass, 2 1/8" x 1 1/4" x 1/8"	
	591-419-199	Sight Glass, 2" Round x 1/8"	
L	450-030-934	Cover Plate for Heater Opening (Rectangular)	
L1	590-317-579	Gasket for Heater Cover Plate (Rectangular)	
M	450-030-925	Cleanout Plate (1 per joint)	
M1	591-221-271	Cleanout Plate Gasket, 1/2" x 2-7/8" x 15 1/2"	
NS	Available locally	Cleanout bolts and nuts, (2 per cleanout) 1/4" 20 1.75 zinc plated, carriage bolts, 1/4" plain washer, 1/4" – 20 hex nut	
NS	386-300-211	88 Combustion Chamber Kit	
NS	560-340-577	3/8" x 1 1/8" stud & nut for heater cover plate	
	591-632-612	Waterglass (4 oz. Bottle)	

■ Indicates current TPS R/C product