



ecocirc® 20-18

THE ONE PUMP VERSATILE ENOUGH TO REPLACE 70



ecocirc 20-18 Features

- Maximum of 20 feet of head or 18 GPM
- 70W maximum power
- 3 modes - proportional pressure, constant pressure, or adjustable speed control
- Fluid temperature: 14-230°F
- **CircGuard™** - complete integrated system protection
- Automatic air purge to remove any air trapped in the pump
- One turn knob and multicolor LED display for easy reading and setting of the pump
- Check valve included in box
- Insulation shell included



Now, all you need is one pump to meet the biggest share of your market demand. The **ecocirc 20-18** is so versatile, it can replace as many as 70 different pumps available today. It's a highly efficient variable speed ECM smart circulator that's ideal for HVAC applications.

Your customers will use less water and pay lower utility bills, while you'll drastically reduce the inventory in your warehouses and on your trucks. Plus, you'll get outstanding support from your Bell & Gossett rep and our unparalleled service network.

ecocirc+ 20-18 Features

The ecocirc+ 20-18 connects wirelessly with a smartphone to provide full control. It comes with all of the standard features found on the ecocirc 20-18, plus the following premium features:

- Bluetooth communication+
- 0-10V input+
- Temperature control+
- eAdapt autolearn and Night Mode+
- Digital display+



Dimensions and Weights

ecocirc / ecocirc+ 20-18 (Flanged)			
A	6.38" (162 mm)	E	4.57" (116 mm)
B	3.54" (90 mm)	F	5.9" (150 mm)
C	0.47" (12 mm)	G	3.74" (95 mm)
D	3.15" (80 mm)	H	3.54" (90 mm)
I	3.74" (95 mm)	H1	4.29" (109 mm)
H2	1.73" (44 mm)	H3	1.73" (44 mm)
Weight	5.86 lb. (2.66 kg)		

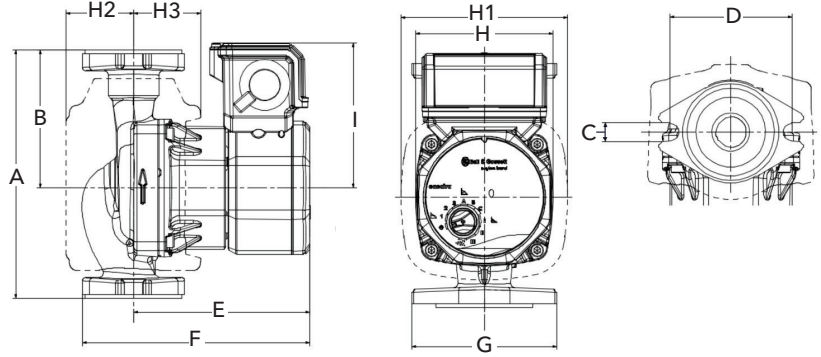

Part Numbers

ecocirc 20-18 Part Number	Description
60B0B1000	ecocirc Cast Iron Flanged
60B0B1001	ecocirc Stainless Steel Flanged
60B0B1002	ecocirc Stainless Steel Union

ecocirc+ 20-18 Part Number	Description
60B0B1003	ecocirc+ Cast Iron Flanged
60B0B1004	ecocirc+ Stainless Steel Flanged
60B0B1005	ecocirc+ Stainless Steel Union

Performance

Fixed Speed Curve

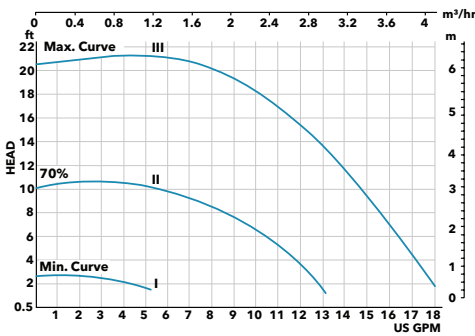

Constant Pressure Curve

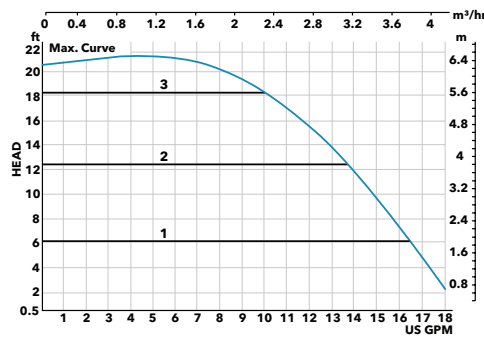

Proportional Pressure Curve

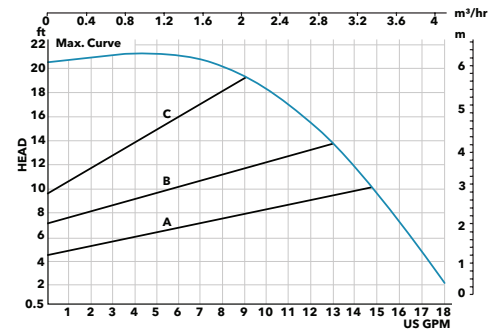

Cross Reference Chart

ecocirc 20-18 / ecocirc+ 20-18	Bell & Gossett	Grundfos	Taco	Armstrong	Wilo
ecocirc 20-18 CI Flanged	ecocirc 19-16 CI, NRF-9L/W, NRF-22, NRF-33	Alpha2 15 55 (+), Alpha1 15-55, UPS 15-58, UP 15-42, UP 15-10	VT-2218 (+), VR-1816, 0018e (+), 0015e3, 007e, 006e3, 005-F, 007-F, 008-F, 0015-F	Compass H 20-20CI (+), Astro 2 210 CI, Astro 2 220 CI, Astro 2 230 CI, Astro 2 250 CI	Stratos ECO, Stratos 1.25 X 3- (+), 20 Star S-21
ecocirc 20-18 SS Flanged	ecocirc 19-16 SS, NBF-12F/LW, NBF-22, NBF-25, SSF-12F/LW, SSF-22	Alpha2 15-55 (+), Alpha1 15-55, UPS 15-55, UPS 15-35, UP 15-29	005-BF, 007-BF, 008-BF, 0015-SF	Compass H 20-20 (+), SSF Astro 2 210 SS, Astro 2 230 SS, Astro 2 250 SS	Star Z S-21
ecocirc 20-18 SS Union	NBF-8S/LW, NBF-9U/LW, NBF-10S/LW, NBF-12U/LW, NBF-18S/LW, NBF-22U, SSF-9U/LW, SSF-12U/LW, SSF-22U	UP 15-10B, UP 15-18B, UP 15-29SU	003-B, 003-BC, 006-B, 006-BC, 008-BC	Compass H 20-20 (+), SSU Astro 2 220, SSU Astro 2 225, SSU Astro 2 225, BS	N/A

Note: Stainless steel (SS) versions are NSF-61 certified. (+) designates the cross reference to the ecocirc+ 20-18.

Standard warranty of 24 months on all models. Extended warranty when registering the ecocirc 20-18 via iOS or Android app.

For more information please visit our website at <http://bellgossett.com/ecocirc2018>



Xylem Inc.
8200 N. Austin Avenue
Morton Grove, IL 60053
Phone: (847) 966-3710
www.xylem.com/bellgossett

Bell & Gossett is a trademark of Xylem Inc. or one of its subsidiaries.
© 2021 Xylem Inc. ECO2018-BGSS-CWHVAC R1 December 2021

