

Job Name:

System Reference:

Date:

Indoor Unit:
MFZ-KJ15NA



Wireless Remote Controller



GENERAL FEATURES

- Floor-mounted indoor unit mounts on the floor or up to 5" above the floor
- Floor front panel access to the filter for ease of cleaning
- Perfect for difficult areas that may be smaller or don't have usable space on the walls
- Multiple fan speed options: Quiet, Low, Medium, High, Super-high, Auto
- Quiet operation
- Multi-flow vane for faster heating
- Multiple control options available:
 - Hand-held Remote Controller (provided with unit)
 - kumo cloud[®] smart device app for remote access
 - Third-party interface options
 - Wired or wireless controllers
- Unit can be recessed mounted into wall

SPECIFICATIONS: MFZ-KJ15NA

Cooling Capacity ^{1, 3}		BTU/H	15,000
Heating Capacity ^{2, 3}		BTU/H	18,000
Electrical	Voltage, Phase, Frequency		208/230V, 1 phase, 60Hz
	Guaranteed Voltage Range		V AC 187-253
	Voltage: Indoor - Outdoor, S1-S2		V AC 208/230
	Voltage: Indoor - Outdoor, S2-S3		V DC 24
	Short-circuit Current Rating (SCCR)		5
MCA		A	1
Blower Motor Full Load Amperage		A	0.62
Blower Motor Output		W	30
Airflow Rate at Cooling, Dry		CFM	374-328-282-237-198
Airflow Rate at Cooling, Wet		CFM	318-279-240-201-168
Airflow Rate at Heating, Dry		CFM	470-325-290-254-212
Sound Pressure Level (Cooling)		dB(A)	43-40-36-31-28
Sound Pressure Level (Heating)		dB(A)	49-39-36-34-29
External Static Pressure		in.WG	N/A
Drain Pipe Size		In. (mm)	5/8 (15.88)
Condensate Lift Mechanism, Maximum Distance		In. (mm)	N/A
Heat Exchanger Type			Plate fin coil
External Finish Color			White
Unit Dimensions	W: In. (mm)		29-17/32 (750)
	D: In. (mm)		8-15/32 (215)
	H: In. (mm)		23-5/8 (600)
Package Dimensions	W: In. (mm)		32-2/16 (816)
	D: In. (mm)		10-13/16 (275)
	H: In. (mm)		27-12/16 (693)
Unit Weight		Lbs. (kg)	33 (15)
Package Weight		Lbs. (kg)	41 (18.5)
Refrigerant	Type		R410A
	Charge		Lbs, oz 3, 5

Notes:

Nominal Conditions	¹ Cooling (Indoor // Outdoor)	°F	80 DB, 67 WB // 95 DB, 75 WB
	² Heating at 47°F (Indoor // Outdoor)	°F	70 DB, 60 WB // 47 DB, 43 WB

³Capacity varies based on the number of indoor units operating and the model of the Multi-zone Outdoor Unit. For reference to connected capacity charts, please refer Multi-zone Outdoor Unit Operational Performance.

ACCESSORIES: MFZ-KJ15NA

Floor Mount Air Guide	□ MAC-760FD-E
Anti-allergy Enzyme Filter	□ MAC-408FT-E
kumo touch™ RedLINK™ Wireless Controller	□ MHK2
Deluxe MA Remote Controller ¹	□ PAR-40MAAU
Simple MA Controller ¹	□ PAC-YT53CRAU-J
Touch MA Controller ¹	□ PAR-CT01MAU-SB
Wired Remote Sensor	□ M21EAA307
Wireless Temperature and Humidity Sensor	□ PAC-USWHS003-TH-1
System Control Interface ²	□ MAC-334IF-E
Wireless Interface 2	□ PAC-USWHS002-WF-2
Thermostat Interface	□ PAC-US444CN-1
kumo station®	□ PAC-WHS01HC-E
USNAP Interface	□ PAC-WHS01UP-E
IT Extender	□ PAC-WHS01IE-E
BACnet® and MODBUS® Interface	□ PAC-UKPRC001-CN-1
External Fan / Heater Control Relay Adapter	□ CN24RELAY-KIT-CM3
Lockdown Bracket for Hand-held Remote Controllers	□ RCMKP1CB
Blue Diamond Sensor Extension Cable — 15 Ft.	□ C13-103
Blue Diamond Alarm Extension Cable — 6.5 Ft.	□ C13-192
Blue Diamond MultiTank — collection tank for use with multiple pumps	□ C21-014
Blue Diamond Rubber Foot Pads	□ F10-010
Mini Condensate Pump — 230 volt application	□ SI30-230
MegaBlue Advanced Blue Diamond Condensate Pump w/ Reservoir & Sensor	□ X87-835 - 110 to 250V
MaxiBlue Advanced Blue Diamond Mini Condensate Pump w/ Reservoir & Sensor (110V) up to 48,000 BTU/H[recommended]	□ X87-711 - 110V
Advanced Blue Diamond Mini Condensate Pump w/ Reservoir & Sensor (208/230V) [recommended]	□ X87-721 - 208/230V
MicroBlue Blue Diamond Mini Condensate Pump (110/208/230V) up to 18,000 BTU/H	□ X85-003
Fascia Kit for MicroBlue Pump – mounts the MicroBlue and sensor directly beneath the indoor unit	□ T18-016
Drain Pan Level Sensor	□ SS610E
(30A/600V/UL) [fits 2" X 4" utility box] - Black	□ TAZ-MS303
(30A/600V/UL) [fits 2" X 4" utility box] - White	□ TAZ-MS303W
Guides air flow for floor mount model when a concealer is used to hide the floor mount.	□ MAC-760FD-E

¹ Requires MAC-334IF-E

² Allows indoor units to connect to an MA Controller

DIMENSIONS: MFZ-KJ15NA

Unit: inch

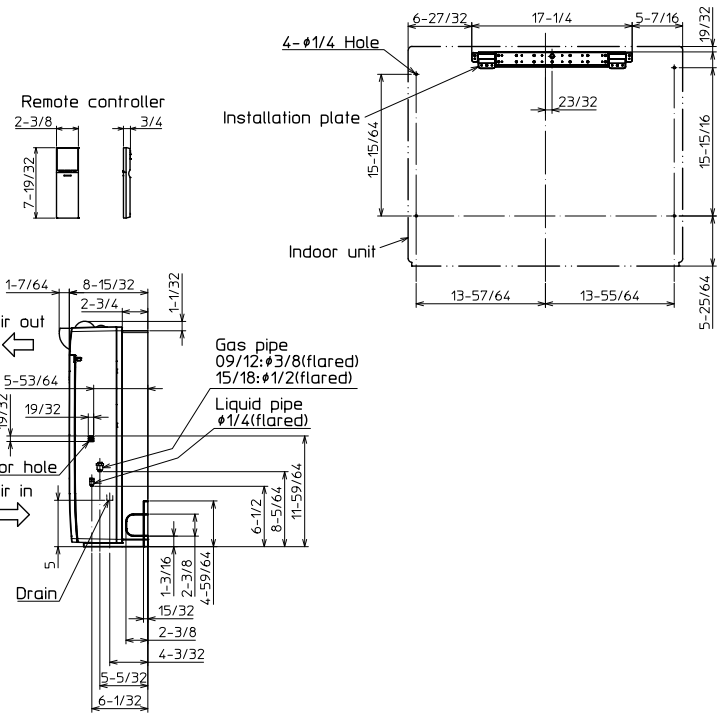
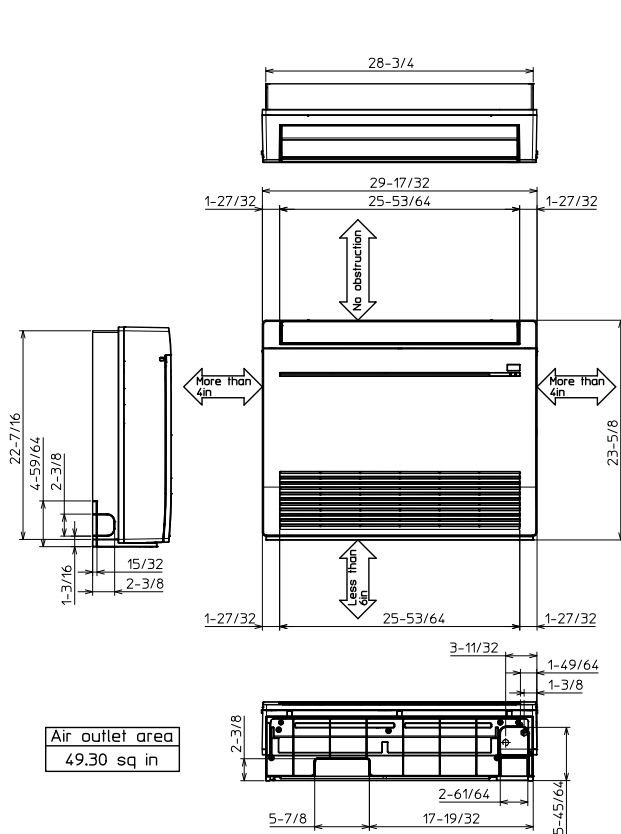

		09 / 12	15 / 18
Pipe cover	For liquid line	1-1/16 O.D	
	For gas line	1-1/16 O.D	1-7/32 O.D
Piping	Liquid line	Flared connection 1/4	
	Gas line	Flared connection 3/8	Flared connection 1/2
Drain hose	Heat insulator 1-9/64 O.D	Connection point 5/8 O.D	Effective length 13-25/32 (case of right backward piping)

