

**viega**

**ProRadiant**  
SYSTEMS

*One Company... One Partner... Delivering System Solutions.*

# Combi-Flex™ System

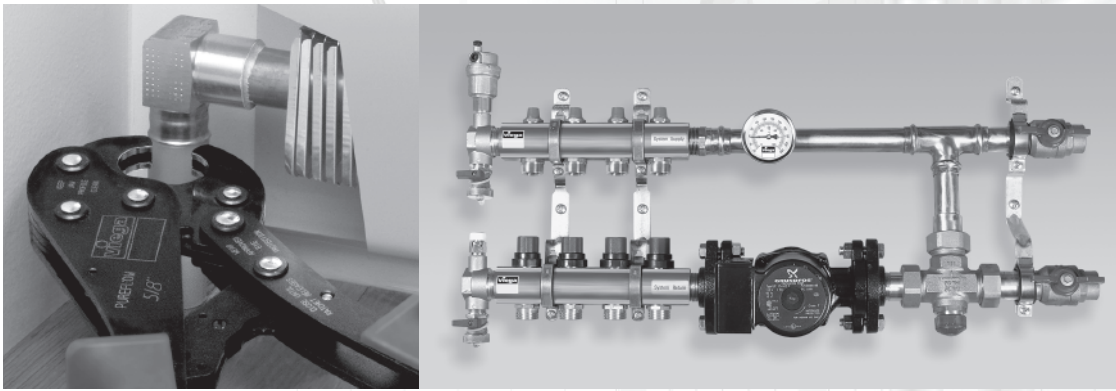

**Installation Manual**

# CONTENTS

<b>1 System Advantages And Benefits</b>		<b>5 Mixing Station</b>	
1.1 Combi-Flex System Concept	2	5.1 Introduction	23
1.2 Application Benefits	3	5.2 Specifications	24
1.3 Mixing Station And Manifold Benefits	4	5.3 Assembled Mixing Station	25
1.4 Why Choose Viega's FostaPex Tubing	5	5.4 System Start Up	26
		5.5 High Temperature Limit	27
<b>2 Product Description</b>	6-13	<b>6 FostaPex Tubing</b>	
<b>3 Combi-Flex System Design</b>		6.1 General	28
3.1 Piping and Controls	14	6.2 Advantages Of FostaPex	28
3.2 Wiring Schematics	15	6.3 Properties And Performance	28
3.3 Basic Heating Control	16	6.4 FostaPex Tubing Markings	28
3.4 Settings For Combi-Flex System	17	6.5 FostaPex Tubing Dimensions	28
3.5 FostaPex Tubing And Pump Sizing	18, 19	<b>Appendix A</b>	
<b>4 Combi-Flex Installation</b>		Making A FostaPex Press Connection	29, 30
4.1 Baseboard Connection with FostaPex	20	<b>Appendix B</b>	
4.2 Handling FostaPex Tubing	21	Piping Schematics	31
4.3 Wood Frame Construction	21	<b>Appendix C</b>	
4.4 Steel Construction	21	Pump Sizing	32
4.5 Supporting FostaPex Tubing	21		
4.6 Electric Grounding	22		
4.7 Repairs	22		
4.8 Concrete Constructions	22		
4.9 Tubing Expansion And Contraction	22		

## 1.1 Combi-Flex System Concept

Viega's Combi-Flex system improves traditional high temperature systems to meet the changing needs of customers looking for greater efficiency and comfort. Combi-Flex offers three main enhancements to improve traditional high temperature hydronic systems:

- **Piping**
- **Manifolds**
- **Controls**

### **Piping**

The Combi-Flex system uses Viega's FostaPex in lieu of copper. FostaPex, made of a fully dimensioned inner PEX tubing with a thin outer layer of aluminum and polyethylene. This form stability allows for fewer joints behind walls thus adding security to the installation. FostaPex utilizes Viega's press technology so there are no fittings to sweat, no flame required and every pressed connection is leak free.

### **Manifolds**

One easy and common piping arrangement used in most efficient radiant systems is a manifold system. Using FostaPex and a manifold system eliminates additional fittings, valves and pumps. By incorporating manifolds in a high temperature hydronic system, balancing and zoning are simplified. Remote manifolds may be utilized to decrease the amount of pipe needed.

### **Controls**

Another step to increase efficiency and comfort of a traditional high temperature hydronic system is through constant circulation and outdoor reset control. Outdoor reset is the term used to describe a modulating water temperature system. As the outdoor temperature increases the water temperature decreases and vice versa. By using constant circulation expansion and contraction noises are eliminated.

## 1.2 Application Benefits

### Applications

- Baseboard
- Radiators
- Kickspace Heaters
- Fan Coil Units
- Towel Warmers

### Advantages

- Reduced installation labor
- Fewer joints and potential leaks hidden in walls
- Press connections assure secure, leak-proof connections
- Zoning advantages
- Minimizes contraction and expansion noise
- 25 year warranty on Viega tubing
- Eliminates zone pumps
- Same temperature for every heat emitter

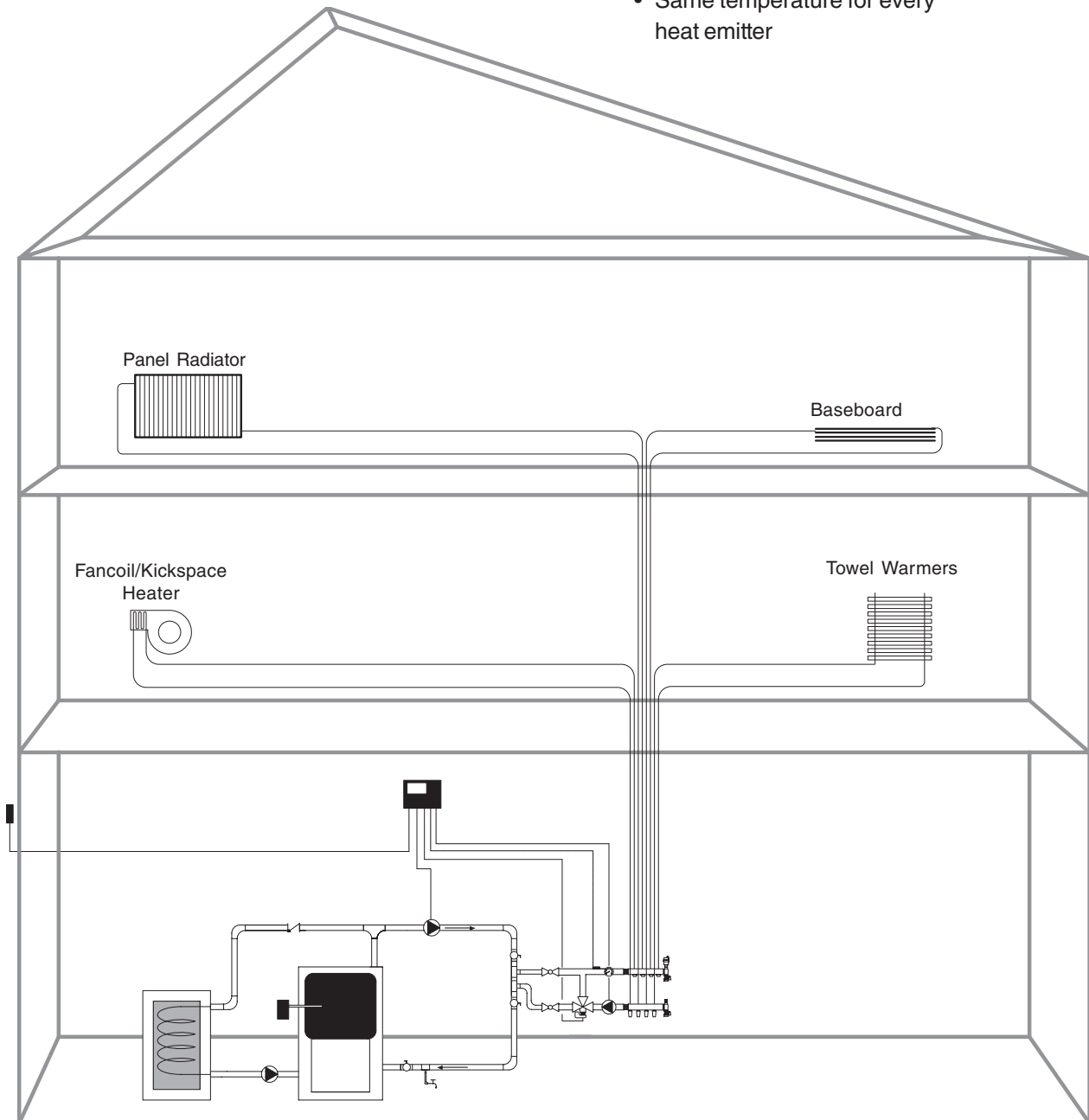

Figure 1.2

## 1.3 Mixing Station And Manifold Benefits

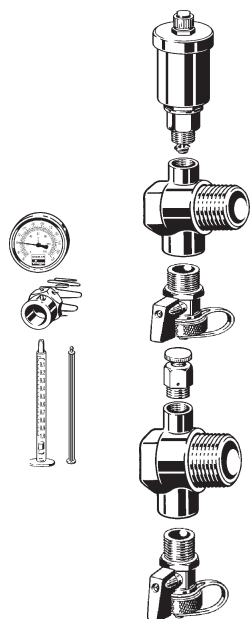

Figure 1.3a

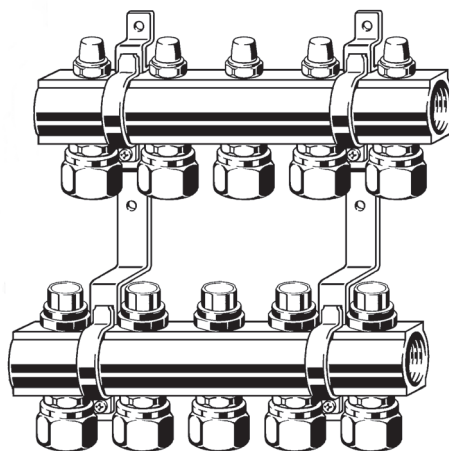

Figure 1.3b

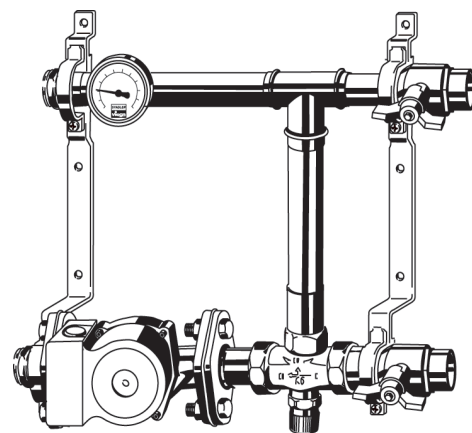

Figure 1.3c

### Manifold Accessory Set Includes

- 2 - 1" NPT end caps
- 1 - Air vent
- 1 - Air bleeder
- 2 - Purge valves
- 1 - Strap-on temperature gauge set

### 1 Inch Manifold Includes

- 2 - 6-5/8" Spacing brackets (for compact remote mounting)
- 2 to 12 - Outlets per header
- 2 to 12 - Balancing valves
- 2 to 12 - Shut-off valves

### Mixing Station Includes

- 2 - Ball valves
- 1 - Pump ( low, medium, high )
- 1 - Diverting valve with integrated high temp. limit
- 2 - 6-5/8 Spacing mounting brackets

### Options

- Powerhead
- SVC circuit flow meter
- SVC circuit ball valve
- SVC circuit temperature gauge seat
- Circuit temperature gauge

### Options

- Two position actuator
- Three position actuator

### Benefits

- Compact
- Easy to control
- Easy to install
- Versatile
- Choice of three pumps
- Peace of Mind
- Preassembled
- Ultimate floor protection

## 1.4 Why Choose Viega's FostaPex Tubing

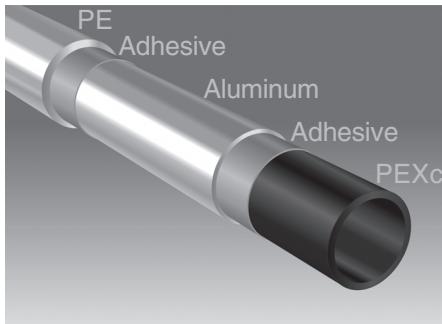
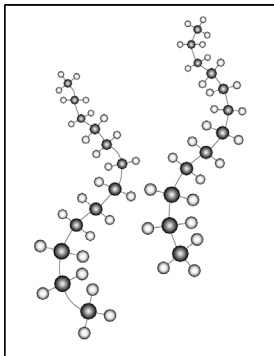

Figure 1.4

Viega's FostaPex tubing offers the following advantages

- Bendable and holds its shape
- Integrated UV resistance
- Aluminum layer as oxygen barrier
- Expansion rate similar to copper
- Fast, easy and flexible installation
- Corrosion resistant
- Durable
- Quiet water flow
- No chemicals added in electronic crosslinking
- 25 year warranty

### PEXc Base Tubing



1. Molecular build-up of polyethylene.

- Dark spheres: carbon (C)
- Light spheres: hydrogen (H)

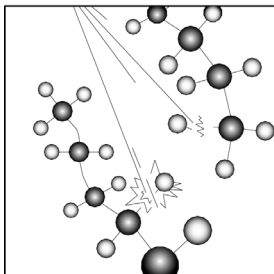

2. With the help of accelerated electrons, hydrogen is split off from hydrocarbon chains.

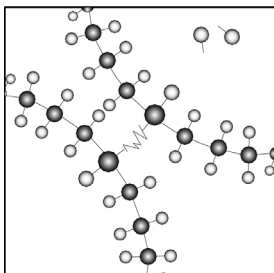

3. The resultant radicals immediately move toward each other.

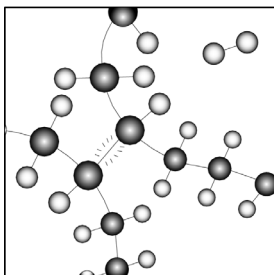

4. Hydrocarbon chains cross-link through electron pairing. Hydrogen atoms form hydrogen molecules.

**Result:** Optimum material properties for heating and water tubing are achieved through electronic cross-linking of molecules, which eliminates the risk of long-term temperature aging.

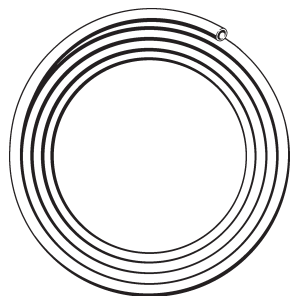

### FOSTAPEX TUBING - COILS

FostaPex tubing adds aluminum and PE outer layers to the tubing to provide **Form Stability** and an oxygen barrier. FostaPex can be bent and will hold its new shape - excellent for exposed runs in basements and baseboard connections. Can be used anywhere that Pextron is applicable.

Part Description	Stock Code	Unit
1/2" Coil - 150 feet	35 020	coil
1/2" Coil - 400 feet	35 021	coil
5/8" Coil - 150 feet	35 030	coil
3/4" Coil - 150 feet	35 040	coil
1" Coil - 150 feet	35 060	coil



### FOSTAPEX TUBING - STRAIGHT LENGTHS

This tubing is the same FostaPex tubing used in our coils, but sold in 20 foot straight lengths for easy installation on straight runs.

Part Description	Stock Code	Unit
1/2" Straight Length - 20 feet	35 520	pkg/25
3/4" Straight Length - 20 feet	35 540	pkg/25
5/8" Straight Length - 20 feet	35 530	pkg/25
1" Straight Length - 20 feet	35 560	pkg/10

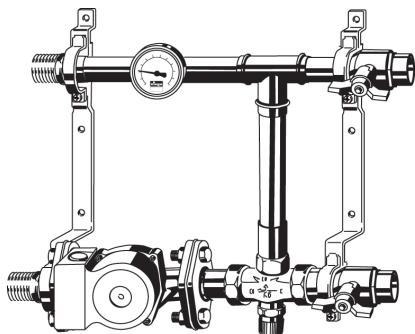

### MIXING STATION

The Viega Mixing Station provides a simple solution for supply water modulation. Applications: hydronic systems with water supply temperature higher than 150°F, staple up radiant systems or when connecting to modulating, condensing boilers, or water heaters, etc.

Part Description	Stock Code	Unit
With low head pump	12 097	pc
With medium head pump	12 099	pc
With high head pump	12 117	pc

**ASSEMBLED MIXING STATION**

The Viega Assembled Mixing Stations are pre-fabricated and pressure tested distribution stations, ready for wall mounting with circulator, mixing valve, supply and return manifold, isolation valves, air elimination and purge equipment. For detailed configurations refer to page 27.

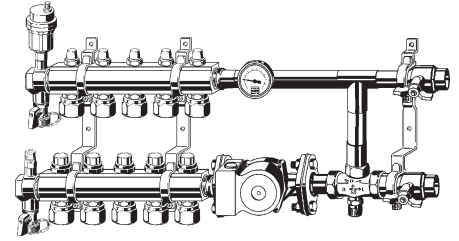

Part Description	Low	Medium	High
Mixing Station, 0 outlets	12 097	12 099	12 117
Mixing Station, 1 outlets	12 098	12 100	12 118
Mixing Station, 2 outlets	12 075	12 086	12 064
Mixing Station, 3 outlets	12 076	12 087	12 065
Mixing Station, 4 outlets	12 077	12 088	12 066
Mixing Station, 5 outlets	12 078	12 089	12 067
Mixing Station, 6 outlets	12 079	12 090	12 068
Mixing Station, 7 outlets	12 080	12 091	12 069
Mixing Station, 8 outlets	12 081	12 092	12 070
Mixing Station, 9 outlets	12 082	12 093	12 071
Mixing Station, 10 outlets	12 083	12 094	12 072
Mixing Station, 11 outlets	12 084	12 095	12 073
Mixing Station, 12 outlets	12 085	12 096	12 074

**1 INCH MANIFOLDS**

These 1 inch diameter supply and return manifolds come with 6-5/8" spacing brackets for compact remote mounting. This system provides balancing and shut-off valves. End connections are 1" NPT. The manifold can be attached easily to the Viega Mixing Station.

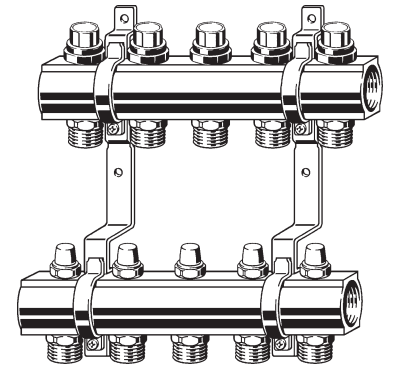

Part Description	Stock Code	Unit
Manifold, 2 outlets	15 012	set
Manifold, 3 outlets	15 013	set
Manifold, 4 outlets	15 014	set
Manifold, 5 outlets	15 015	set
Manifold, 6 outlets	15 016	set
Manifold, 7 outlets	15 017	set
Manifold, 8 outlets	15 018	set
Manifold, 9 outlets	15 019	set
Manifold, 10 outlets	15 020	set
Manifold, 11 outlets	15 021	set
Manifold, 12 outlets	15 022	set



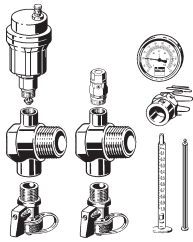

### MANIFOLD ACCESSORY SET

Manifold accessory set includes two 1" NPT end caps, one air vent, one air bleeder, two purge valves, and one strap-on temperature gauge set.

Part Description	Stock Code	Unit
1" NPT	15 023	set

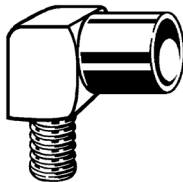

### PRESS COPPERTUBING ELBOWS

90 degree elbows connect PEX to copper tubing. Press fitting makes baseboard connections fast and simple. Tubing elbow fits over standard copper tubing or baseboard. Note - 1/2" PEX x 1/2" tubing is same part as for 1/2" PEX x 3/4" fitting (machined to fit both sizes). Solder the elbow to copper, then make PEX press connection.

Part Description	Stock Code	Unit
1/2" PEX x 1/2" Copper Tubing or 3/4" Fitting	19 307	pkg/5
1/2" PEX x 3/4" Copper Tubing	19 308	pkg/5
5/8" PEX x 3/4" Copper Tubing	19 312	pkg/5
3/4" PEX x 3/4" Copper Tubing	19 309	pkg/5
3/4" PEX x 1/2" Copper Tubing or 3/4" Fitting	19 311	pkg/5

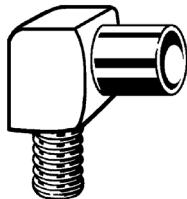

### PRESS COPPER FITTING ELBOWS

90 degree elbows connect PEX to copper fittings. Press fitting makes baseboard connections fast and simple. Fitting elbow fits into standard copper fittings or flared end of baseboard. Solder elbow to copper, then make PEX press connection.

Part Description	Stock Code	Unit
1/2" PEX x 1/2" Copper Fitting	19 310	pkg/5
1/2" PEX x 1/2" Copper Tubing or 3/4" Fitting	19 307	pkg/5
5/8" PEX x 3/4" Copper Fitting or 1/2" Tubing	19 313	pkg/5
3/4" PEX x 3/4" Copper Fitting or 1/2" Tubing	19 311	pkg/5

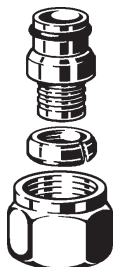

### SVC COMPRESSION PEX ADAPTERS

These compression fittings attach PEX tubing to Viega manifolds or other SVC connections.

Part Description	Stock Code	Unit
1/2" PEX x SVC	19 009	pkg/10
5/8" PEX x SVC	19 010	pkg/5
3/4" PEX x SVC	19 011	pkg/10

**SVC PRESS ADAPTERS**

These adapters allow the Viega press connection system to be used on manifolds or other SVC connection components.

Part Description	Stock Code	Unit
1/2" PEX x SVC	19 409	pkg/10
5/8" PEX x SVC	19 413	pkg/5
3/4" PEX x SVC	19 410	pkg/5



**SVC CIRCUIT FLOW METER**

Flow meter for accurate circuit flow monitoring and balancing. In-line unit attaches to valve seat of return manifold. Integral valve for rough balancing or shut off. Graduated up to 2.1 gpm (8 liters/min).

Part Description	Stock Code	Unit
0.5 to 2.1 gpm	15 036	pc



**SVC CIRCUIT BALL VALVE**

Attach to valve seats on manifolds to provide individual circuit shut-off capability. Useful for purging one circuit at a time, or for circuit shut-off on 1-1/2" manifolds.

Part Description	Stock Code	Unit
Circuit Ball Valve	15 031	pc



**SVC CIRCUIT TEMPERATURE GAUGE SEAT**

Temperature gauge seat for individual circuit. Mounts onto manifold port.

Part Description	Stock Code	Unit
Temperature Gauge Seat	15 034	pc

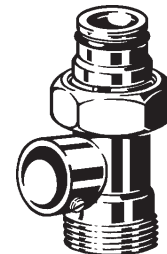

**CIRCUIT TEMPERATURE GAUGE**

1-3/8" diameter temperature gauge for individual circuits. Mounts in circuit temperature gauge seat (stock code 15 034, see above).

Part Description	Stock Code	Unit
32 -180°F	15 035	pc

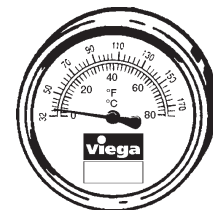

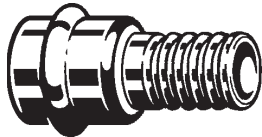

### PRESS ProPress ADAPTERS

Use these adapters to transition directly from PEX to copper tubing. Press fitting makes flameless plumbing and hydronic heating connections fast and simple. The ProPress tool, available through Ridgid, is required for the copper side. ProPress is compatible with type K, L, and M copper tubing only.

Part Description	Stock Code	Unit
1/2" PEX x 1/2" C	67 620	5/pkg
1/2" PEX x 3/4" C	67 626	5/pkg
3/4" PEX x 1/2" C	67 630	5/pkg
3/4" PEX x 3/4" C	67 640	5/pkg
5/8" PEX x 1/2" C	67 627	5/pkg
5/8" PEX x 3/4" C	67 628	5/pkg



### PRESS COUPLINGS

These couplings mate two sections of PEX tubing with the press connection. Used for repairing damaged sections or connecting long runs.

Part Description	Stock Code	Unit
3/8" PEX	63 000	25/pkg
1/2" PEX	63 020	25/pkg
1/2" PEX x 3/4" PEX	63 050	25/pkg
5/8" PEX	63 030	5/pkg
3/4" PEX	63 040	25/pkg
3/4" PEX x 1" PEX	63 055	10/pkg
1" PEX	63 060	10/pkg

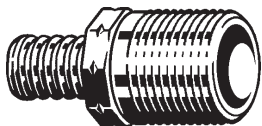

### PRESS MALE NPT ADAPTERS

Use male adapters to make a press connection between PEX tubing and FNPT threaded pipe.

Part Description	Stock Code	Unit
3/8" PEX x 1/2" MNPT	60 505	25/pkg
1/2" PEX x 1/2" MNPT	60 520	25/pkg
1/2" PEX x 3/4" MNPT	60 525	25/pkg
5/8" PEX x 1/2" MNPT	60 530	5/pkg
5/8" PEX x 3/4" MNPT	60 531	5/pkg
3/4" PEX x 1/2" MNPT	60 542	25/pkg
3/4" PEX x 3/4" MNPT	60 540	25/pkg
3/4" PEX x 1" MNPT	60 545	25/pkg
1" PEX x 3/4" MNPT	60 555	10/pkg
1" PEX x 1" MNPT	60 560	10/pkg

**PRESS FEMALE NPT ADAPTERS**

Use female adapters to make a press connection between PEX tubing and MNPT threaded pipe.

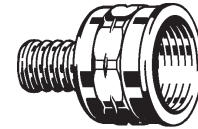

Part Description	Stock Code	Unit
1/2" PEX x 1/2" FNPT	61 520	25/pkg
1/2" PEX x 3/4" FNPT	61 525	25/pkg
3/4" PEX x 3/4" FNPT	61 540	25/pkg
1" PEX x 3/4" FNPT	61 545	10/pkg
1" PEX x 1" FNPT	61 560	10/pkg

**PRESS SLEEVES**

These stainless steel sleeves provide a secure and leak proof press connection for Viega tubing and press fittings. The view hole ensures a perfect connection every time. Use only with Viega press tooling.



Part Description	Stock Code	Unit
1/2" PEX	61 020	pkg/100
5/8" PEX	61 030	pkg/100
3/4" PEX	61 040	pkg/100
1" PEX	61 060	pkg/100

**PRESS TOOLS**

With its ratcheting design, the Viega Press tool ensures a perfect connection every time. The tool cannot be opened until the fitting has been properly pressed. Color coded handles allow easy identification of each size. Works with Pextron and FostaPex.

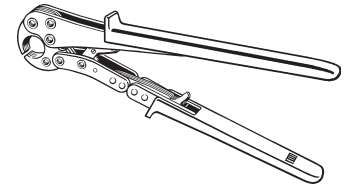

Part Description	Stock Code	Unit
1/2" Press tool - yellow	50 020	pc
5/8" Press tool - red	50 030	pc
3/4" Press tool - blue	50 040	pc
1" Press tool - orange	50 060	pc

**FOSTAPEX PREP TOOLS**

These tools peel the outer PEX and aluminum layers from FostaPex tubing, allowing it to be used with the standard press fitting system.

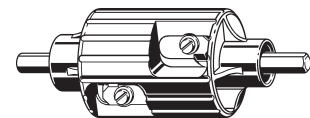

Part Description	Stock Code	Unit
1/2" & 3/4"	54 030	pc
1" & 5/8"	54 060	pc
Replacement Blade	54 075	pc

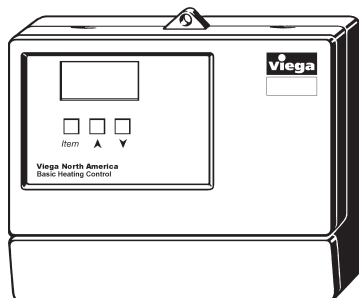

### BASIC HEATING CONTROL

This basic electronic outdoor reset control modulates system water temperature as outdoor temperature fluctuates. Features include:

- Modulating mixing valve control
- Supply temperature high limit
- Seasonal pump activation
- Boiler activation
- Mixing valve and pump exercising

Part Description	Stock Code	Unit
Control	16 015	pc

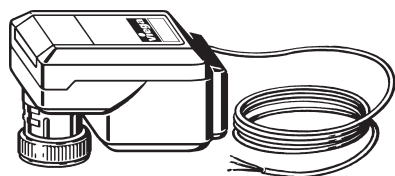

### THREE POSITION ACTUATOR FOR STATIONS

This three position (floating) actuator controls the Injection Station or a Diverting Valve from a 24 VAC floating signal. Compatible with Basic and Advanced Heating Controls.

Part Description	Stock Code	Unit
Three Position Actuator for Stations	18 003	pc

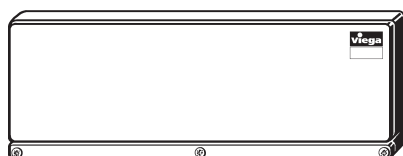

### ZONE CONTROL

5 or 6 zone control box for thermostats and powerheads. Switchable for demand or outdoor pump control. 50 VA internal transformer included. 120 VAC supply (cord included for simple plug in applications). 24 V output for powerheads. Dry pump relay contacts to activate the Pump and Boiler Relay (below).

Part Description	Stock Code	Unit
6 Zones, 120 VAC	18 032	pc

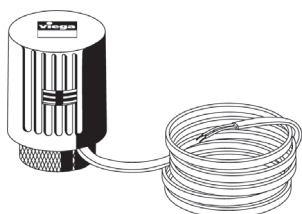

### POWERHEAD

Fits 1" manifold return valves to provide individual zone control. 24 VAC, normally closed. Connects to standard Zone Control or can be wired directly with thermostats. For use ONLY with 1" manifolds in this catalog - not compatible with older 1-1/4" headers.

Part Description	Stock Code	Unit
24 V, 3VA	18 028	pc



### PUMP AND BOILER RELAY

Pump and boiler relay provides simple activation of pump and boiler from a dry signal, such as a Zone Control or the Advanced Snow Melt Control, or a powered signal from a thermostat. 120 VAC supply. Includes internal 24 VAC transformer. Provides high-voltage contacts for pump activation and separate dry contacts for boiler T-T or low-voltage applications.

Part Description	Stock Code	Unit
10 A, 120 V, DPDT	18 033	pc

**THERMOSTATS**

Basic 24 V three wire room thermostat for radiant heating applications. Live anticipator to match response of radiant heating systems. Adjustable from 43 to 86°F. Flip-up cover provides clean appearance. LED indicator to show call for heat simplifies installation and troubleshooting.

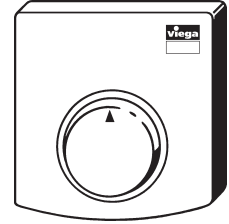

Part Description	Stock Code	Unit
Thermostat - Basic	18 029	pc

Advanced thermostat includes all of the features of the Basic model (powered anticipator, LED, and flip-up cover) while adding setback and floor sensing options. Setback switch allows 9°F manual setback.



Part Description	Stock Code	Unit
Thermostat - Setback	18 030	pc

**LOCK CLIP**

Double ratchet allows easy and secure installation of FostaPex. Fasteners can be connected to allow neat installation of multiple lines. Quick installation using drywall or wood screws. Stand off design keeps tubing away from contact with subfloors, studs, or joists.



Part Description	Stock Code	Unit
1/2" Lock Clip	58 072	100/pkg
3/4" Lock Clip	58 073	50/pkg
1" Lock Clip	58 074	50/pkg

For 5/8" FostaPex use 3/4" Lock Clip 58 073

**SUSPENSION CLIP TUBING FASTENERS**

These suspension type tubing hangers can be used to support FostaPex tubing hanging below joists, or to protect tubing passing through joists from abrasion.

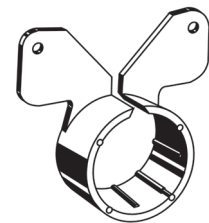

Part Description	Stock Code	Unit
1/2" PEX	55 020	50/pkg
3/4" PEX	55 040	50/pkg
1" PEX	55 060	50/pkg

For 5/8" FostaPex use 3/4" clip 55 040

## 3.1 Piping And Controls

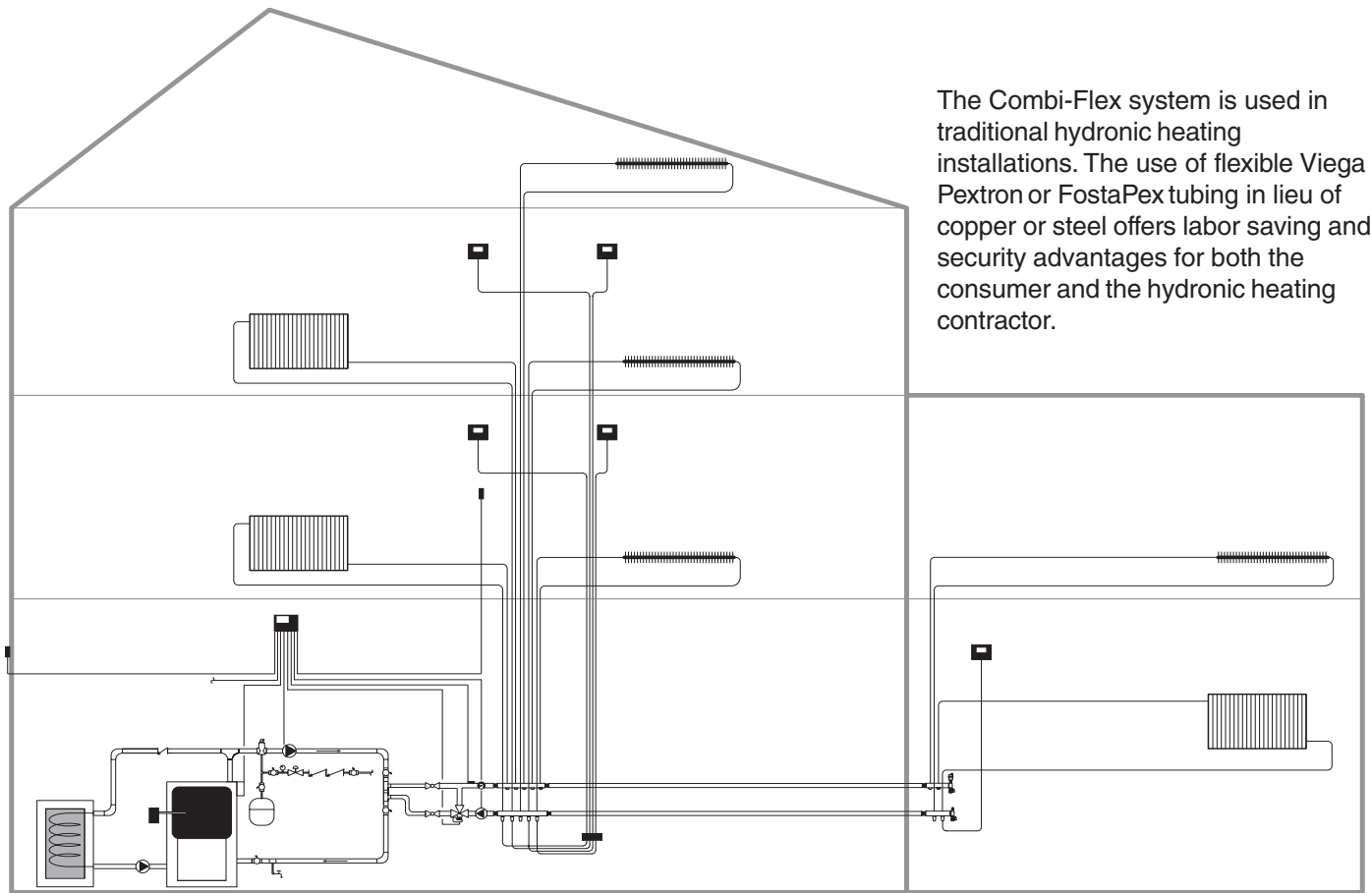

The Combi-Flex system is used in traditional hydronic heating installations. The use of flexible Viega Pextron or FostaPex tubing in lieu of copper or steel offers labor saving and security advantages for both the consumer and the hydronic heating contractor.

Figure 3.1a

- S1 = Supply Sensor
- S2 = Outdoor Sensor
- S3 = Indoor Sensor
- P1 = Primary Loop
- P2 = System Pump
- P3 = DHW Pump
- TS = Room Thermostats

Note 1: Maximum distance between primary loop tees less than 4xO.D. of primary loop diameter.

Note 2: Leave one circuit constantly operating solely off outdoor reset.

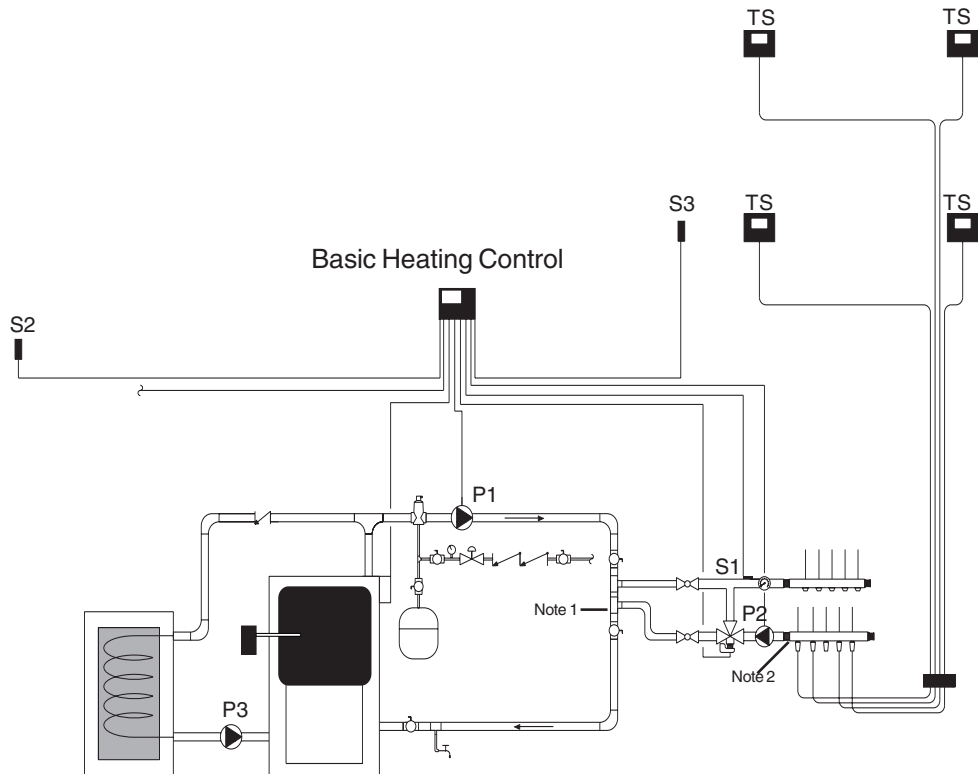

Figure 3.1b

## 3.2 Wiring Schematics

A manifold system allows any one or more of the circuits to be adapted for control by a thermostat. The following are some typical zone wiring schematics.

**Important Note:**  
Installation by a licensed electrician is recommended. Installation and use of this equipment should be in accordance with provisions of the U.S. National Electric Code, applicable local code and pertinent industry standards.

### ONE ZONE APPLICATION

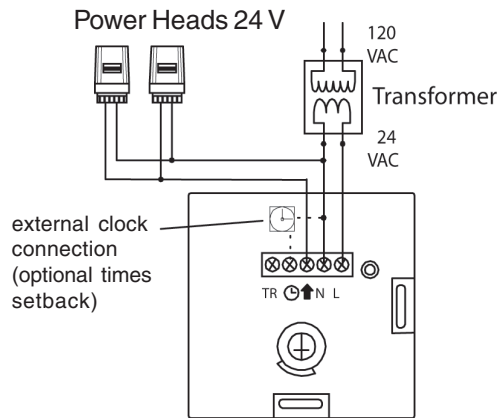

Figure 3.2a

### MULTI ZONE APPLICATION

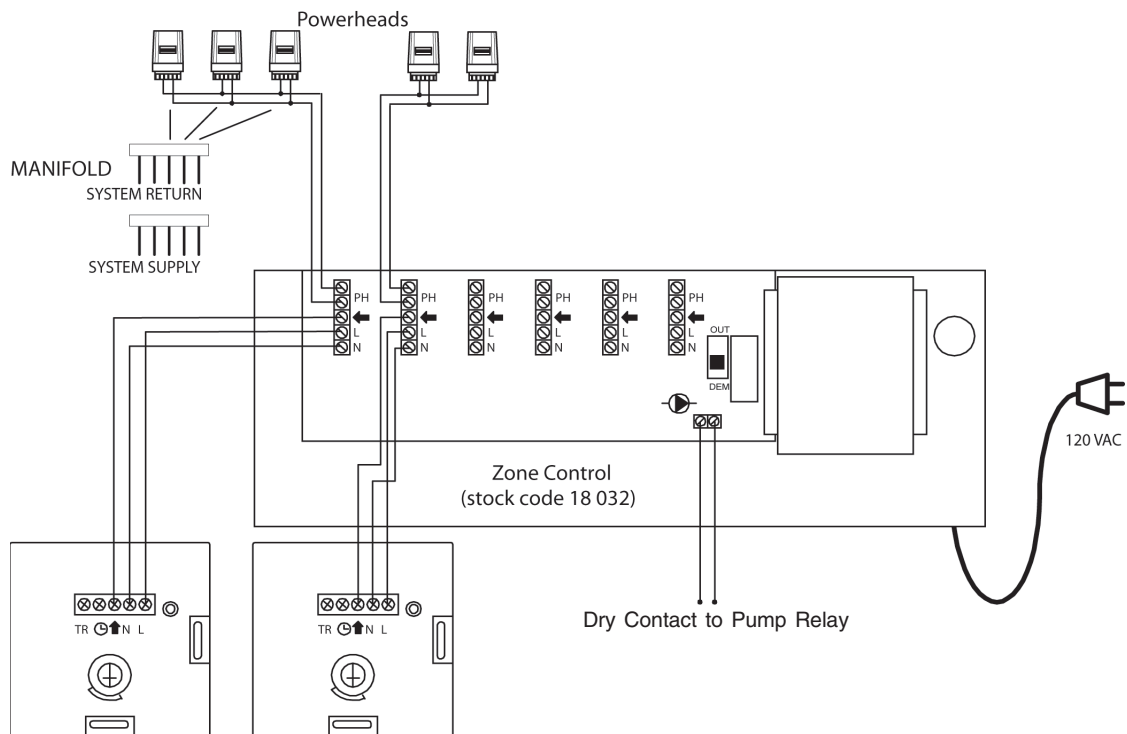

Figure 3.2b



## 3.3 Basic Heating Control

The Viega Basic Heating Control is designed to control the supply water temperature of a hydronic system in order to provide outdoor setpoint operation. The Basic Heating Control uses a floating action actuator mounted on a diverting valve to regulate the supply water temperature.

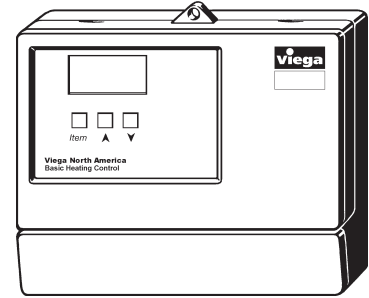

Figure 3.3a

### Additional Functions

- User comfort adjustment to increase or decrease building space temperature
- Advanced settings for fine tuning building requirements
- Optional indoor sensor for room air temperature control
- Test sequence to ensure proper component operation
- 120 VAC power supply
- Powered system pump output
- CSA C US certified (approved to applicable UL standards)

### Outdoor Reset

The Basic Heating Control calculates a mixing supply water temperature based on outdoor air temperature. The control uses an outdoor sensor and a water supply sensor for the calculation. It utilizes a floating action actuator to control the mixing supply temperature. In the Combi-Flex system the actuator is mounted on the Three Way Diverting Valve of the Mixing Station.

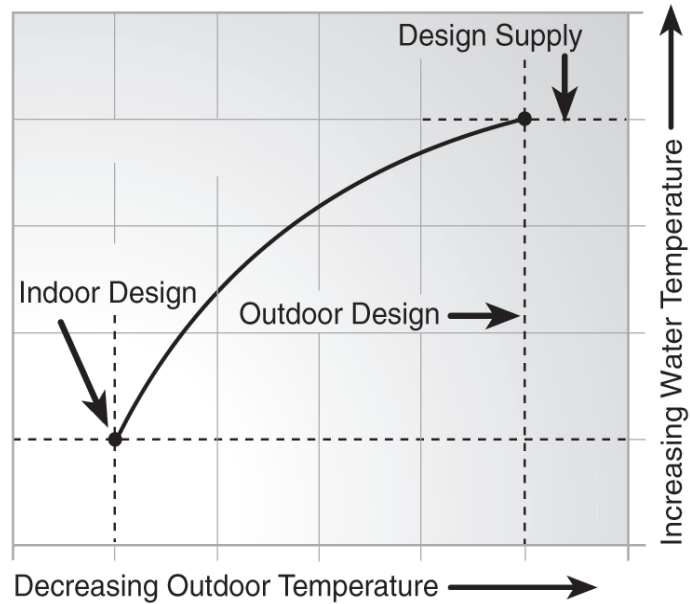

Figure 3.3b

Note: Refer to Basic Heating Control Operation Manual for more detailed information.

### 3.4 Settings For Combi-Flex System

#### Adjusting The Heating Curve

The Basic Heating Control varies the mixed supply water temperature based on outdoor air temperature. The relation between the outdoor air temperature and the water supply temperature is characterized by the heat curve. Since different types of heat emitters require different adjustments of the water supply temperature, the heat curve has to be adjusted to the heat emitter used.

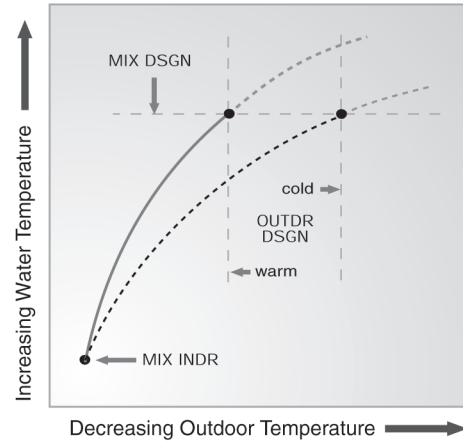

Figure 3.4a

Terminal Unit				
	Baseboard	Radiator	Towel Warmer	Fancoil
MIX DSGN	180°F	160°F	180°F	180°F
MIX MAX	190°F	180°F	200°F	200°F

Table 3.4a

#### Adjust Menu Display Settings To Change Heat Curve

To make an adjustment to a setting in the control, press and hold simultaneously for 1 second, the **Item**, **▲** and **▼** buttons. The display will then show the word **ADJUST** in the top, right corner. Then select the desired item using the **Item** button. Finally, use the **▲** and / or **▼** button to make the adjustment. See sections 3.2 and 3.3 (pages 6 and 7) of the Basic Heating Control Operation Manual for further discussion on these items and their effect on control operation.

#### Example

Heat Emitter: Baseboard

#### MIX DSGN



Adjust the mix design supply temperature from 120°F to 180°F

#### MIX MAX

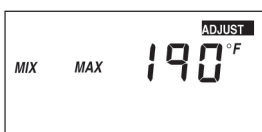
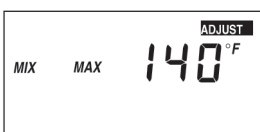

Adjust the maximum supply temperature for the mixing system from 140°F to 190°F.

Note:

This display setting is only visible with the Advanced/Installer DIP switch set to Advanced.

## 3.5 FostaPex Tubing And Pump Sizing

Use Table 3.5a to help design your Combi-Flex system.

**Procedure**

1. Find the heat output needed in the Btu/h column.
2. Follow to the right and read the recommended pump and tubing pressure drop under the column representing the length of the Pextron or FostaPex tubing used.

**Note:** If insulation is not used, select a pump in the non-shaded area. In the shaded area without pipe insulation the temperature drop in the tubing is greater than 10°F.

**Combi-Flex Sizing: Pump Selection For 5/8" Pextron And FostaPex  
(Pressure Drop Through Tubing In Feet Of Head)**

Btu/h	Flow Rate (gpm)	Total Feet of Baseboard (Pressure drop, ft of hd)	Total Tubing Length (ft)							
			50	100	150	200	250	300	350	400
10000	1	18 (0.07)	Low (0.8)	Low (1.6)	Low (2.4)	Low (3.2)	Low (4.0)	Low (4.9)	Low (5.7)	Low (6.5)
20000	2	36 (0.47)	Low (2.7)	Low (5.5)	Low (8.2)	Low (11.0)	Medium (13.8)	Medium (16.5)	Medium (19.2)	High (22.0)
30000	3	54 (1.44)	Low (5.6)	Low (11.2)	Medium (16.8)	High (22.4)				
40000	4	72 (3.15)	Low (9.3)	High (18.6)						

Table 3.5a

Note: Assumed a median value of 550 Btu/h per linear foot of baseboard at 180°F supply water temperature with a 10°F maximum temperature drop through the Pextron or FostaPex tubing. Pump curve information was based on Grundfos circulators (Low head - UP 15-42, Medium head - UP 26-64, High head - UP 26-99 F). Shaded blocks indicate a temperature drop greater than 10°F in uninsulated Pextron or FostaPex supply and return lines.

See Appendix C for Pump selection when using 1/2", 3/4" or 1" Pextron or FostaPex

**Example**

Output needed: 20000 Btu/h  
 Flow rate: 2 gpm  
 Tubing size: 5/8" (use Table 3.5)  
 Total tubing length: 40 ft + 10 ft = 50 ft  
 Feet of baseboard needed: 36 ft  
 Pump selected: Low head

Btu/h	Flow Rate (gpm)	Total Feet of Baseboard (Pressure drop, ft of hd)	Total Tubing Length (ft)							
			50	100	150	200	250	300	350	400
10000	1	18 (0.07)	Low (0.8)	Low (1.6)	Low (2.4)	Low (3.2)	Low (4.0)	Low (4.9)	Low (5.7)	Low (6.5)
20000	2	36 (0.47)	Low (2.7)	Low (5.5)	Low (8.2)	Low (11.0)	Medium (13.8)	Medium (16.5)	Medium (19.2)	High (22.0)
30000	3	54 (1.44)	Low (5.6)	Low (11.2)	Medium (16.8)	High (22.4)				
40000	4	72 (3.15)	Low (9.3)	High (18.6)						

Table 3.5b

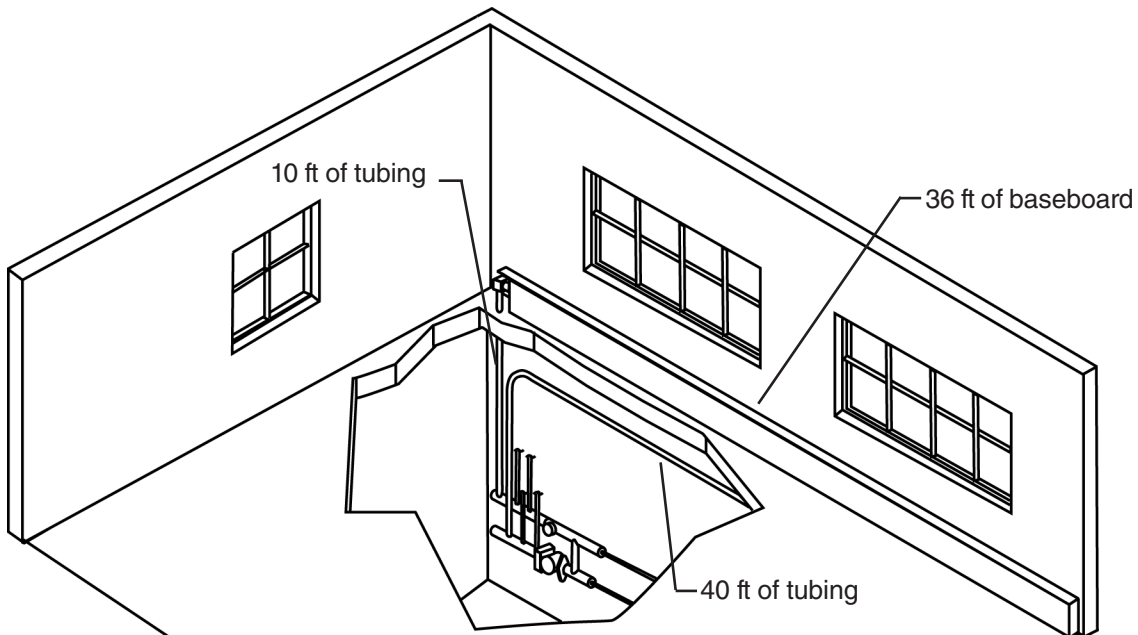

Figure 3.5

## 4.1 Baseboard Connections

A Viega Mixing Station with manifolds installed in the mechanical room is the Combi-Flex distribution starting point. Viega's form stable FostaPex supply and return lines for various high temperature zones are run to each room where baseboard, radiators, kickspace heaters or fan coil units are used.

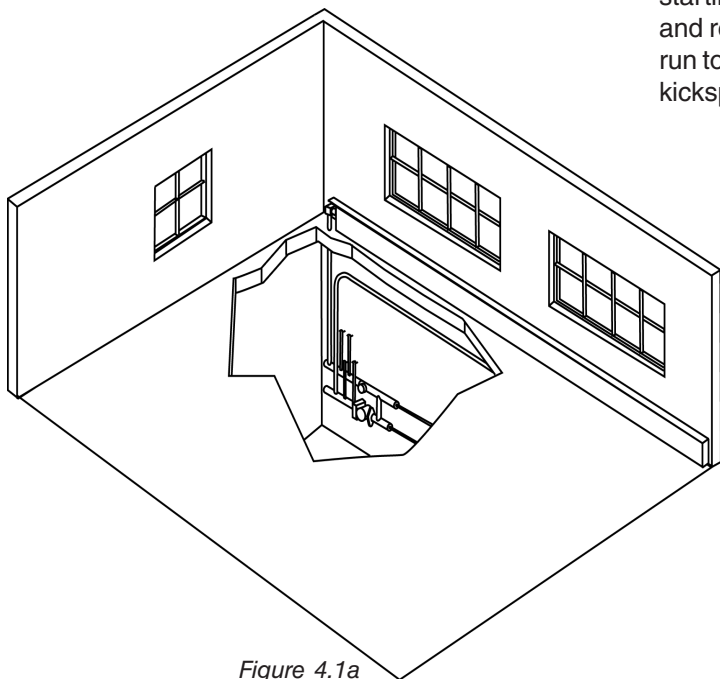

Figure 4.1a

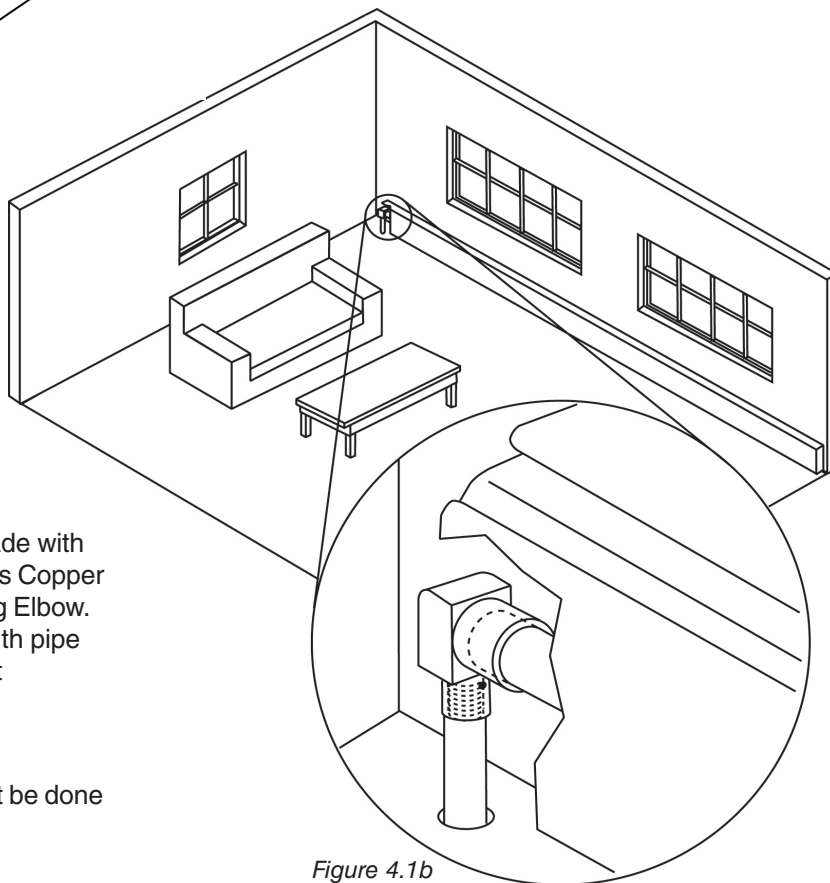

Figure 4.1b

A secure, leak-proof press connection is made with the Viega Press Tool and either a Viega Press Copper Tubing Elbow or a Viega Press Copper Fitting Elbow. Insulate FostaPex supply and return lines with pipe insulation in unheated basements to prevent unwanted heat loss.

**Note:**  
Soldering connection to the baseboard must be done prior to making the Press Connection.

### 4.2 Handling FostaPex Tubing

The properties of FostaPex tubing make it very easy to work with. Some care must be taken to prevent damage to the tubing before and during installation:

- Use care to protect FostaPex tubing from physical damage during storage and installation. Keep the tubing away from sharp objects, open flames, etc., and do not place heavy objects on the tubing.
- Damaged sections of tubing should be cut out and discarded.
- FostaPex, with its aluminum layer, is resistant to UV light, but long term exposure should still be avoided.
- Do not store FostaPex tubing outdoors where it may be exposed to UV light.

### 4.3 Wood Frame Construction

FostaPex tubing is ideal for use in woodframe construction. The ability to bend the tubing around corners and obstacles greatly simplifies installation. FostaPex eliminates the expensive and time consuming use of fittings where tubing turns within a wall. The press tool eliminates the potential fire hazard of soldering close to exposed framing members.

A few rules should be followed when running tubing in woodframe construction:

- Use nailing plates to protect the tubing from nails and screws where it passes through studs.
- Suspension clips are optional but recommended to reduce the potential for noise.

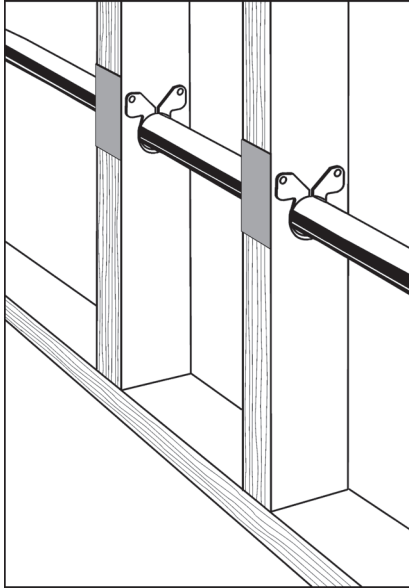

Figure 4.3  
Nailing plates protect tubing from nails as it passes through studs and joists.

### 4.4 Steel Construction

FostaPex works as well in steel frame construction. Where tubing runs through metal studs, suspension clip fasteners should be used to protect tubing from sharp stud edges. Follow the same guidelines fastening and supporting the tubing as for woodframe construction.

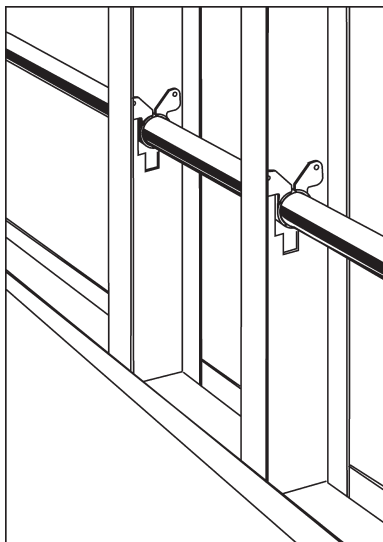

Figure 4.4  
Suspension clip fasteners used to protect tubing from abraision when passng through steel studs.

### 4.5 Supporting FostaPex Tubing

Use only plastic tubing supports. Metal supports may damage the tubing. Tubing should be allowed freedom to move slightly as it expands. Do not clip it tightly into place or locate it where it will be tightly constrained. Use suspension clip where tubing passes through studs or joists to prevent abraision and possible noise as tubing moves.

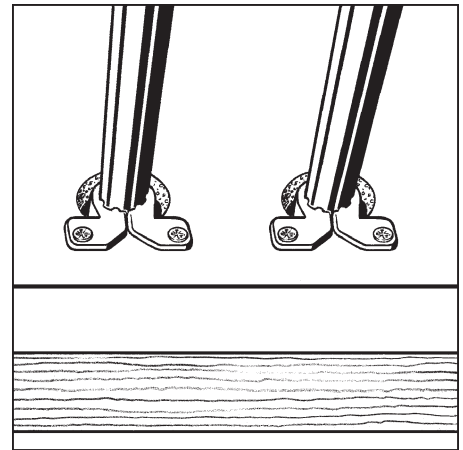

Figure 4.5a  
Suspension clips support tubing in joist penetrations or anywhere abraision is a concern.

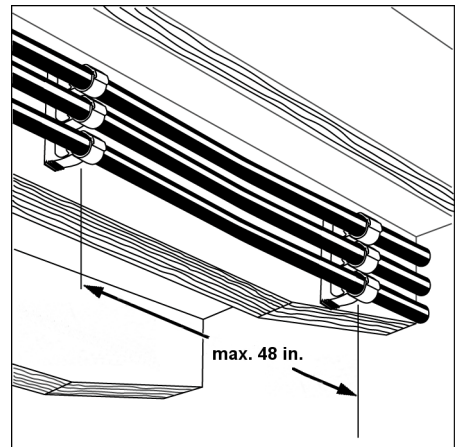

Figure 4.5b  
Tubing supported with Lock clip on horizontal runs.

FostaPex tubing must be fastened at 36-48" intervals in horizontal runs. Use Viega Lock Clip for easy alignment of multiple lines. The stand off design of the clips keeps tubing away from ceilings and subfloors.

## 4.6 Electric Grounding

FostaPex may not be used as an electrical ground.

## 4.7 Repairs

Sections of damaged tubing should be repaired by cutting out the damaged section and installing a repair coupling.

In vertical lines FostaPex tubing should be fastened at intervals of max. 48". The Lock clip stand off design keeps the tubing away from studs.

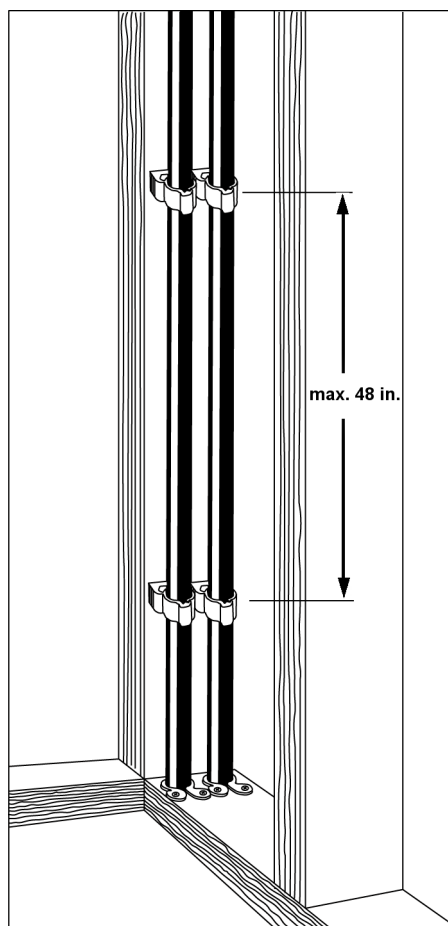

Figure 4.7

Lock Clip fasteners support tubing in vertical runs between floors

## 4.8 Concrete Construction

FostaPex tubing may be run within concrete slabs or below grade where necessary. All penetration points must be sleeved to prevent tubing damage (entry/exit points, expansion joints, etc.). Penetrations in walls, etc. may be sealed with silicone caulk. Do not use oil based caulk. Below grade, support tubing on a firm, packed base and allow sufficient slack for expansion and contraction.

Every effort should be made to use only continuous lengths of tubing within a slab. If the use of fittings buried in concrete is necessary for repairs, all such fittings must be wrapped with insulation, noncorrosive tape, or sleeved to prevent corrosion (this is not necessary in soil).

When running tubing within a concrete slab, the tubing must be fastened to the reinforcing mesh every 2 to 3 feet to prevent it from floating up during the pour

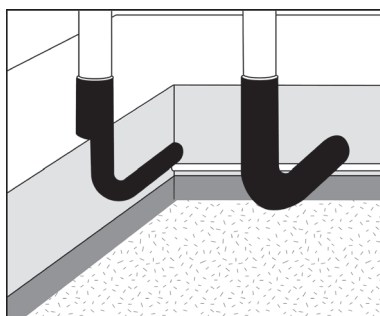

Figure 4.8a

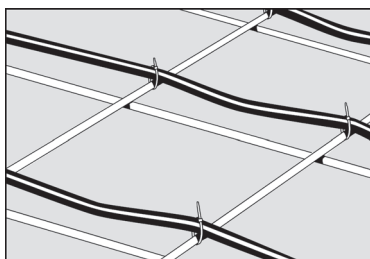

Figure 4.8b

## 4.9 Tubing Expansion and Contraction

The expansion and contraction coefficient of FostaPex is very similar to copper. When installing FostaPex tubing, expansion and contraction of the material should still be considered. FostaPex expands or contracts 0.16 inches in length per 100 feet of tubing for every 10°F change in temperature. FostaPex tubing should not be pulled tight when installed, as cold water will cause tubing to shrink slightly as the system is filled. A slight amount of slack should be left in each run to allow for this contraction without stressing the fittings. Fasteners should not grip tubing tightly so that it can move slightly as expansion takes place. Offsets will give tubing a place to expand and contract without stressing fittings.

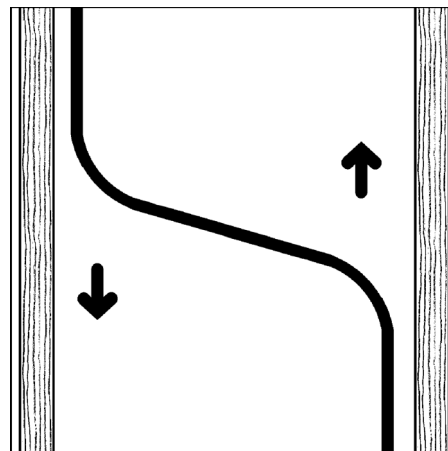

Figure 4.9a

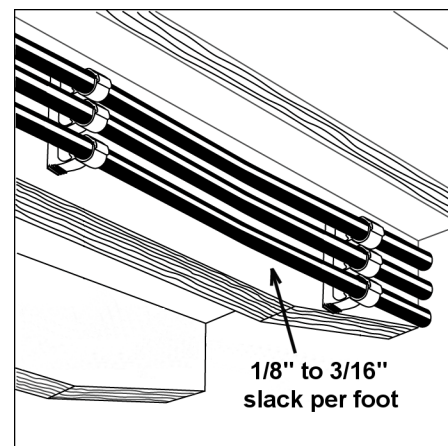

Figure 4.9b

### 5.1 Introduction

Viega's patented Assembled Mixing Stations provide a simple solution for water supply modulation. The station comes pressure tested and pre-assembled making jobsite installation easy, fast and reliable. The station is equipped with either a low, medium or

high head pump. The attached 1" brass manifold includes air vents and purge valves. Two 1" solder isolation ball valves are on the boiler supply and return side to allow the connection to any primary loop or boiler. For zoning, the return header is fitted with shut off valves to accommodate 24V

power-heads. The flow rate of each individual circuit can be adjusted at the balancing valves which are located on the supply header. In a Combi-Flex system FostaPex can be connected to the manifold with Viega's Press Adapters.

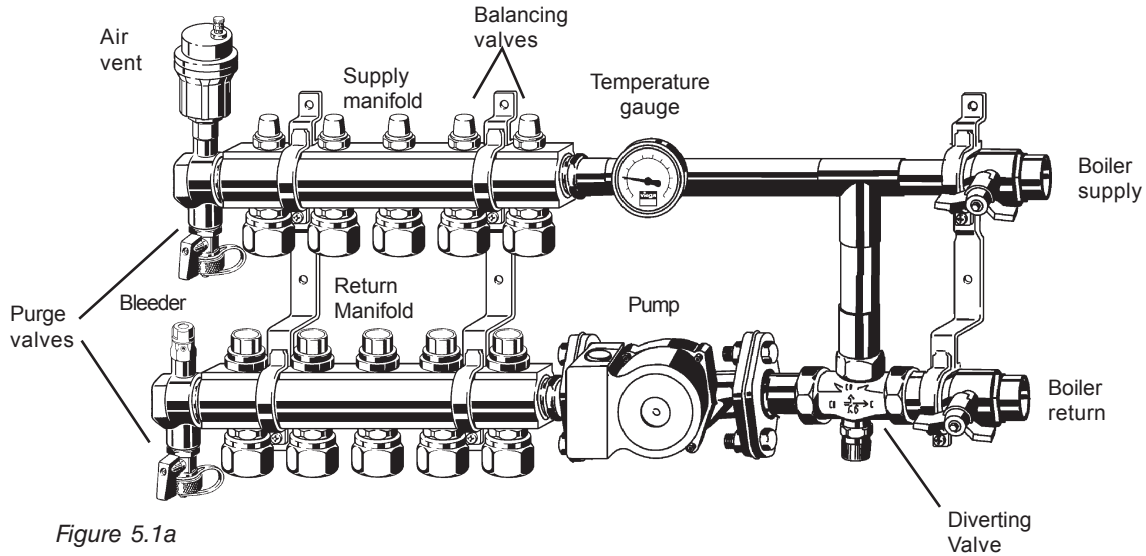

Figure 5.1a

#### Water Supply Modulation

The Diverting Valve in Viega's Mixing Station is located on the system return side of the station. It can direct the system return flow out of the system (open position) or it can recirculate it back into the system (closed position). When the valve is fully open and the system return flow

is diverted to the boiler return side, 100% boiler supply flow will consequently enter the system. If the valve is fully closed, the return flow will recirculate in the system. In combination with Viega's Basic Heating Control and Three Position Actuator the Diverting Valve

modulates the system return flow between the open and closed position which causes a mix of boiler supply and system return flow. Another feature of the Diverting Valve is the integrated high limit which controls the maximum system water supply temperature.

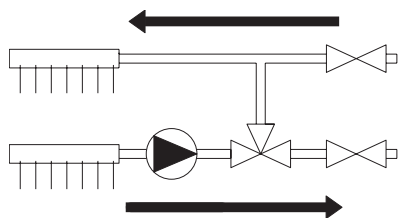

Diverting Valve open  
Figure 5.1b

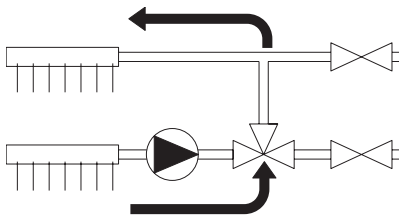

Diverting Valve closed  
Figure 5.1c

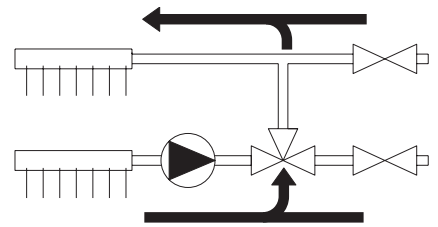

Diverting Valve modulating between open and closed position  
Figure 5.1d



## 5.2 Specifications

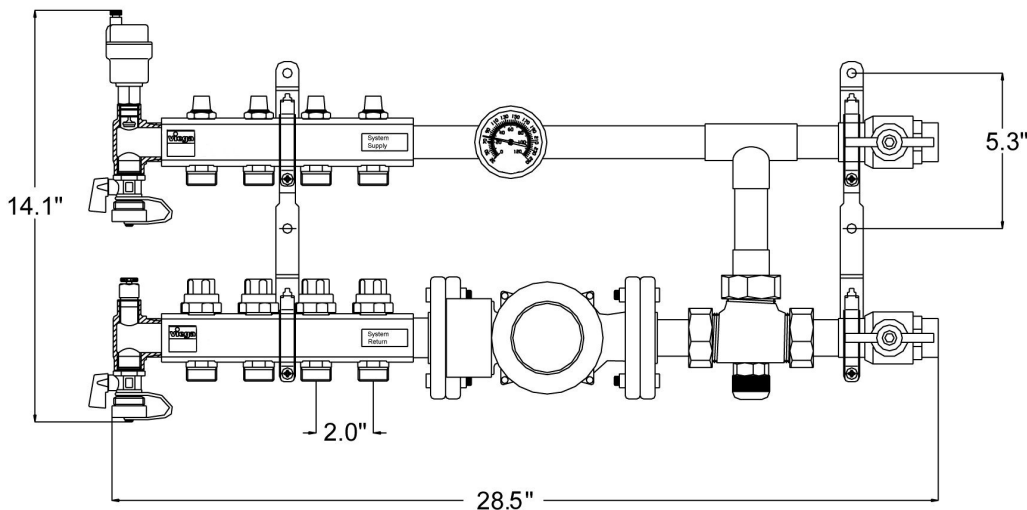

Figure 5.2

### Assembled Mixing Stations includes

- 1 inch brass manifold with compression PEX fittings
- 2 purge valves
- Air vent and purging capability
- 1 inch solder connections for boiler supply and return lines

Side View Depth (D in inches)	
Low Head Pump	6.13
Medium Head Pump	7.13
High Head Pump	7.13

Table 5.2a

Dimensions	
# Outlets	Width
0 outlets	18"
1 outlet	22.5"
2 outlets	24.5"
3 outlets	26.5"
4 outlets	28.5"
5 outlets	30.5"
6 outlets	32.5"
7 outlets	34.5"
8 outlets	36.5"
9 outlets	38.5"
10 outlets	40.5"
11 outlets	42.5"
12 outlets	44.5"

Table 5.2b

### Technical Data

Low head pump curve (UP 15-42)

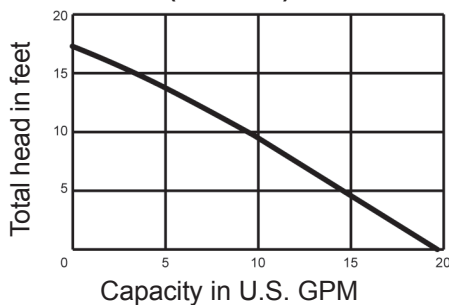

Medium head pump curve (UP 26-64)

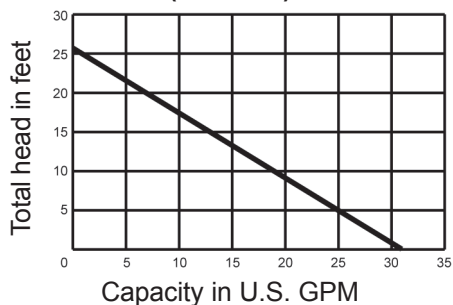

High head pump curve (UP 26-99)

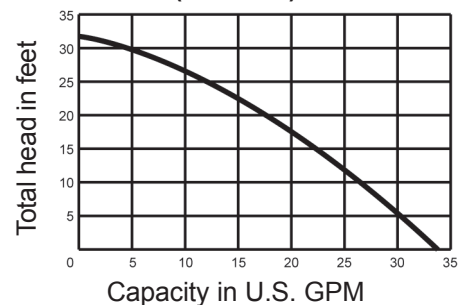

Electrical Data				
Volts	Amps	Watts	HP	Capacitor
115	.74	85	1/25	10mF/180V

Electrical Data				
Volts	Amps	Watts	HP	Capacitor
115	1.7	185	1/12	8mF/180V

Electrical Data				
Volts	Amps	Watts	HP	Capacitor
115	2.15	245	1/6	10mF/180V

5.3 Assembled Mixing Station

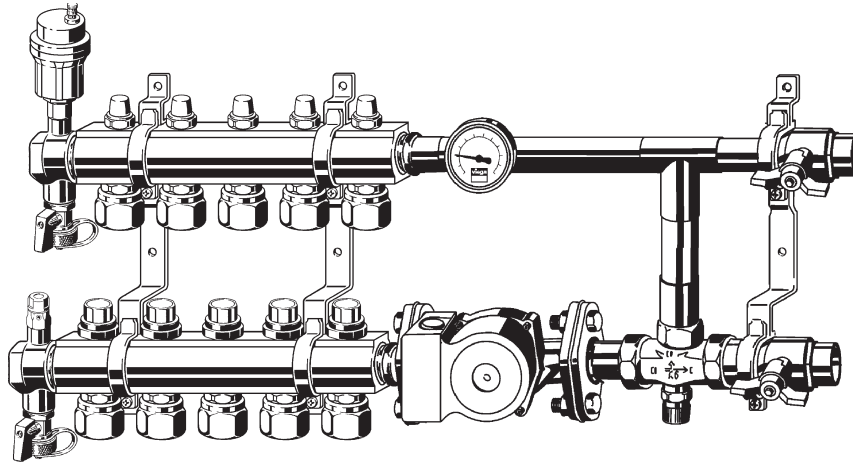

Figure 5.3a

When ordering, specify

- Stock code
- Configurations
- Tubing size

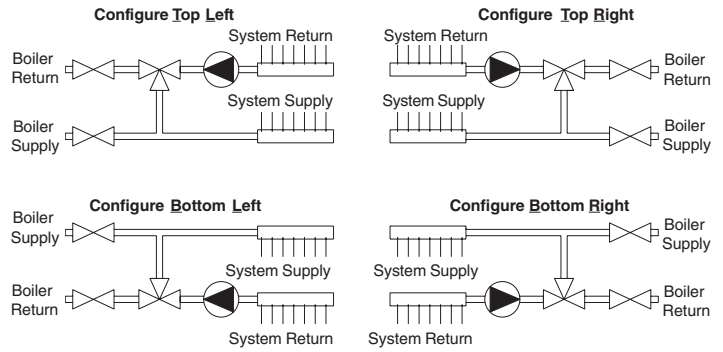

Figure 5.3b

Example

**MS5M-BR-5/16**

Mixing Station ———  
 5 circuits ———  
 Medium head pump ———  
 ——— 5/16" tubing  
 ——— Bottom tubing, Right boiler feed

Assembled Mixing Stations

Station Options	Low head pump	Medium head pump	High head pump
	stock code	stock code	stock code
Mixing Station, 0 outlets	12 097	12 099	12 117
Mixing Station, 1 outlet	12 098	12 100	12 118
Mixing Station, 2 outlets	12 075	12 086	12 064
Mixing Station, 3 outlets	12 076	12 087	12 065
Mixing Station, 4 outlets	12 077	12 088	12 066
Mixing Station, 5 outlets	12 078	12 089	12 067
Mixing Station, 6 outlets	12 079	12 090	12 068
Mixing Station, 7 outlets	12 080	12 091	12 069
Mixing Station, 8 outlets	12 081	12 092	12 070
Mixing Station, 9 outlets	12 082	12 093	12 071
Mixing Station, 10 outlets	12 083	12 094	12 072
Mixing Station, 11 outlets	12 084	12 095	12 073
Mixing Station, 12 outlets	12 085	12 096	12 074

## 5.4 System Start Up

### Filling and Purging

1. Attach drain hose to purge valve hose connection on return header and open valve.
2. Close all but one balancing valve on supply header (under red caps, turn with 5mm allen key). Close isolation ball valve on boiler return line. Remove plastic dust cap or temperature controller from 3-way valve, and make sure that high limit kit is fully open.
3. Open boiler fast fill valve to purge circuit. After purging first circuit, close red balancing valve and open next one. Continue with one circuit at a time until all circuits have been purged.
4. Close purge valve and open all balancing and boiler valves. Reset high-limit kit, and reinstall temperature controller or actuator onto 3-way valve.
5. Any remaining air pockets in the system will be eliminated through the automatic air vent after a few hours of constant circulation.

### Pressure testing

Before the finish floor is installed and during concrete pouring the radiant system must be pressure tested. Air or water may be used as the medium. The following procedure is recommended by Viega. Check the local building code for compliance or additional test requirements.

### Procedure

1. Double check all connections to manifold to ensure proper seal.
2. Connect manifold pressurization kit (1) to any purge valve (2).
3. Pressurize the system to 80 psi to detect potential nail or screw penetrations.
4. The system should hold the 80 psi for a minimum of 24 hours.

### Note:

If the tubing was damaged, repair punctured section with a compression coupling. Maintain pressure during the installation of the finish floor to simplify leak detection if tubing is damaged.

Note: If the system must be purged again in the future for any reason, the high limit kit must be re-opened during purging for full flow.

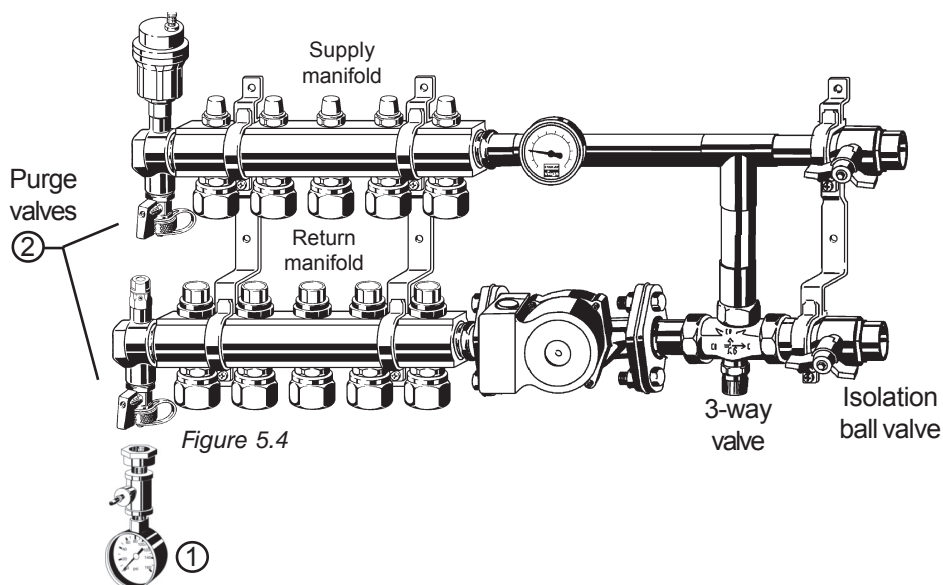

## 5.5 High Temperature Limit

### Operation High Limit

The Mixing Station is provided with a pre-installed temperature High Limit Kit. This kit is installed into the 3-way valve to allow a maximum supply water temperature to be set. This kit must be unscrewed when purging the system and should then be set according to the instructions below.

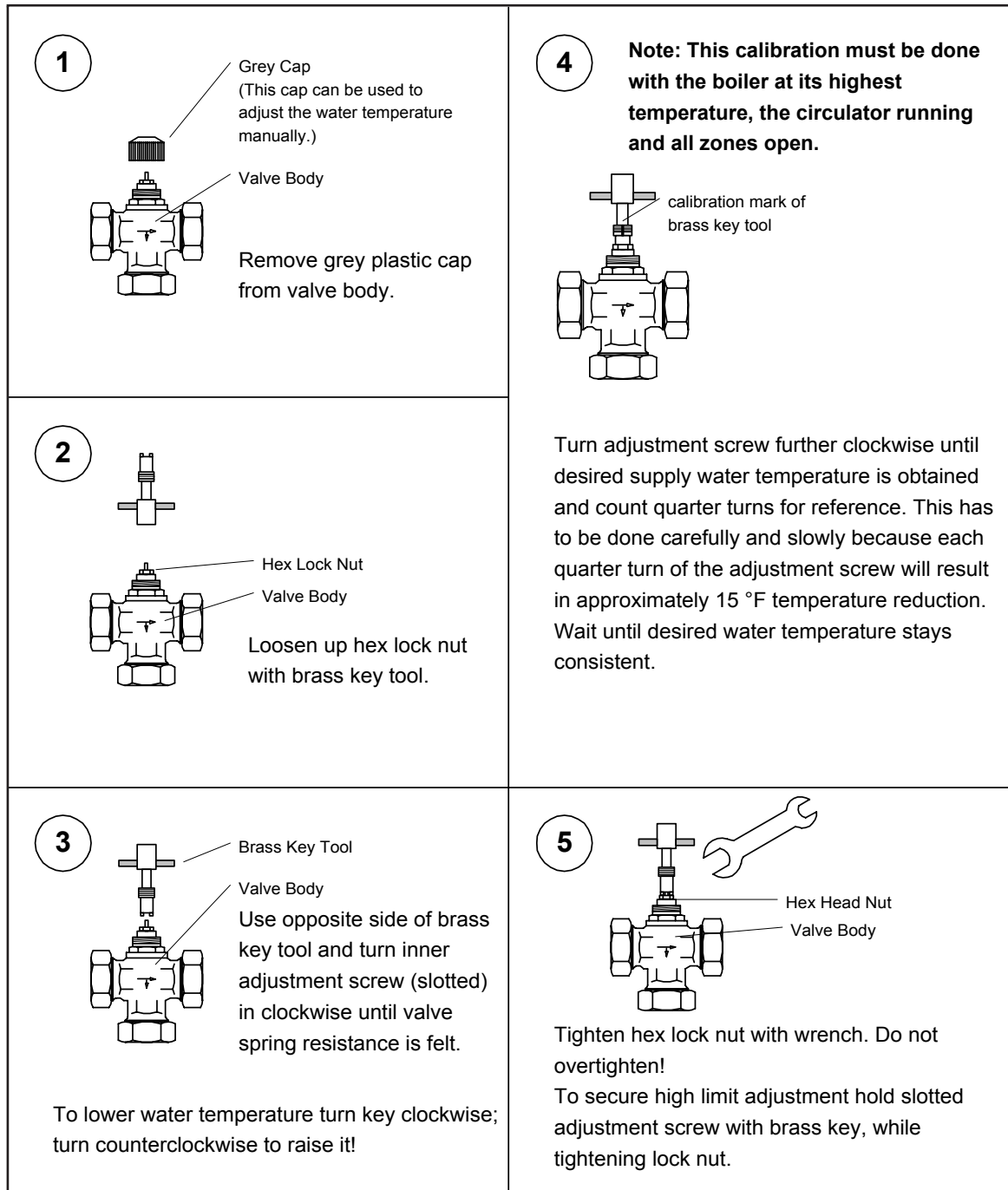

Figure 5.5

## 6.1 General

FostaPex tubing can be easily bent by hand like the Pextron tubing, but holds its shape after bending (combining the benefits of both rigid and flexible tubing). The result is fewer fittings, bend supports, and less labor. FostaPex can be purchased in straight lengths like copper or in coils like regular PEX.

A unique feature of FostaPex is that the inner layer is fully dimensioned Pexcel tubing. The aluminum and outer PE layers surround the inner PEX tubing. This construction allows the inner layer alone to meet all temperature and pressure requirements of the system. Using the prep tool to remove the outer layers allows the use of Viega's Press fitting system, which reduces tooling costs for the contractor and simplifies connections.

## 6.2 Advantages Of FostaPex

The aluminum layer within FostaPex tubing minimizes expansion during temperature changes. The expansion rate of FostaPex is similar to that of copper tubing, reducing the necessity for expansion loops and offsets (refer to 4.9).

FostaPex is ideal for exposed tubing runs where it presents a clean and high appearance.

A bending tool is also available to assist in making smooth, tight bends in FostaPex (Figure 6.2).

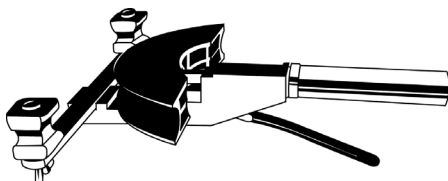

Figure 6.2

## 6.3 Properties And Performance

- Linear Expansion Coefficient:
- 0.16 inch per 100 feet per 10°F
- Thermal stability:
- max. temp. 205°F
  - short periods of up to 230°F in case of system failures
- Permissible operating pressure:
- max. 150 psi

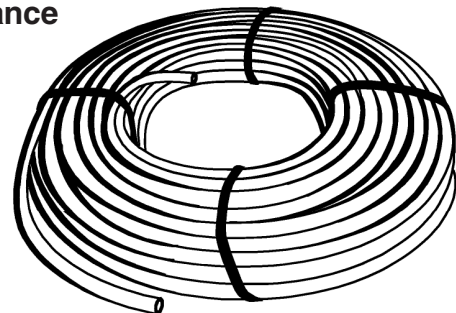

Figure 6.3

## 6.4 FostaPex Tubing Markings

FostaPex tubing is marked every 5 feet with the following information:

Company	VIEGA
Product name	FOSTAPEX™
Nominal tubing size	3/4"
Standard Dimension Ratio	SDR 9
ASTM tubing standards certification	ASTM F876/F2023/F877
Temperature & Pressure rating	180°F 100PSI / 200°F 80PSI
NSF radiant floorheating certification	NSF-rfh
NSF potable water certification	NSF-pw
ICBO listings	ES ER 5944 ES ER 5945 ES ER 5421
Crosslinking method	ELECTRONICALLY CROSSLINKED
Oxygen barrier presence	WITH OXYGEN DIFFUSION BARRIER
Country of manufacture	MADE IN GERMANY
Manufacturer code	HO
Material (crosslinked polyethylene)	PEXc
Manufacturer's identifier	WA 999999
Manufacturer's date code	35065
Length marker	130 feet

## 6.5 FostaPex Tubing Dimensions

Nominal Size	Inner Diameter	Outer Diameter	Wall Thickness	Water Content (GAI/ft)
1/2"	.480	.693	.109	0.009
5/8"	.573	.813	.120	0.013
3/4"	.675	.939	.132	0.018
1"	.870	1.205	.167	0.030

Table 6.5

When piping a Station to a primary loop FostaPex is suggested. FostaPex will hold a bend shape if necessary, is easy to use, has a professional appearance and will reduce installation time.

Follow these steps each time you make a FostaPex connection.

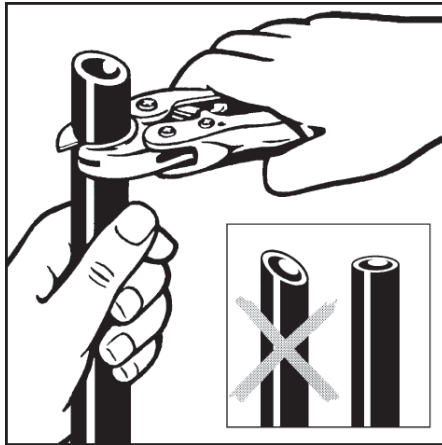

1. Square off tubing to proper length.

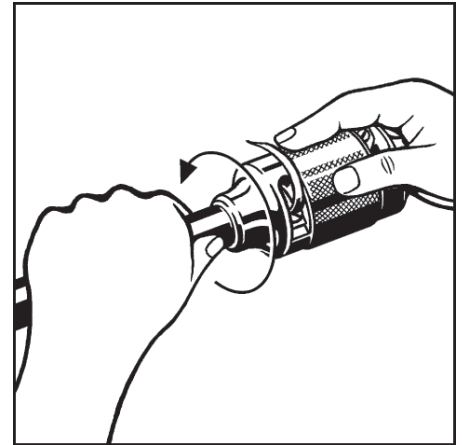

2. Insert FostaPex tubing into prep tool. Push and turn tool until no more resistance is felt and tool spins freely. (This step applies to FostaPex only )

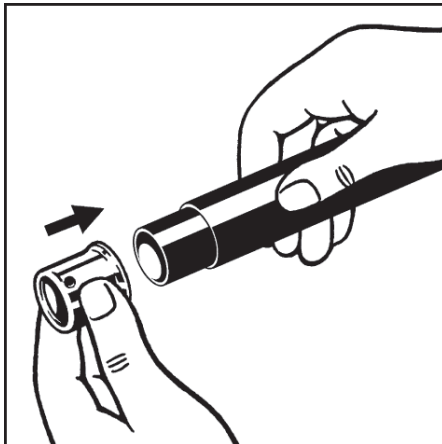

3. Slide press sleeve fully over end of tubing.

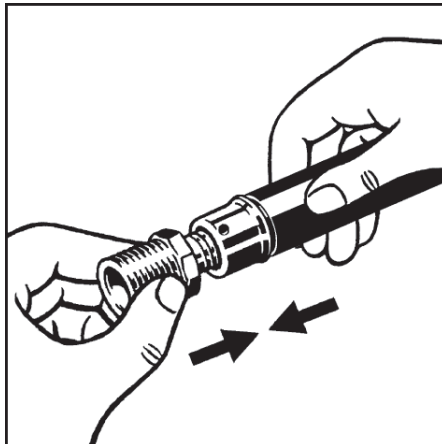

4. Insert compression fitting into tubing and engage fully.

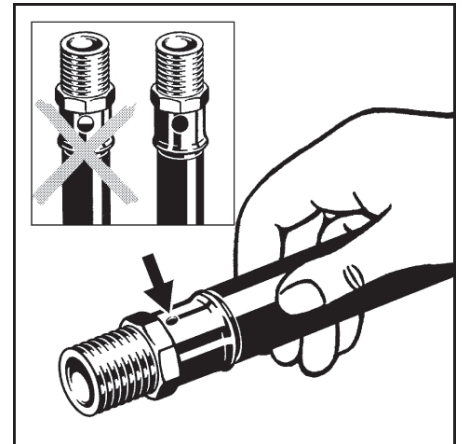

5. Check full tubing insertion at view hole of sleeve.

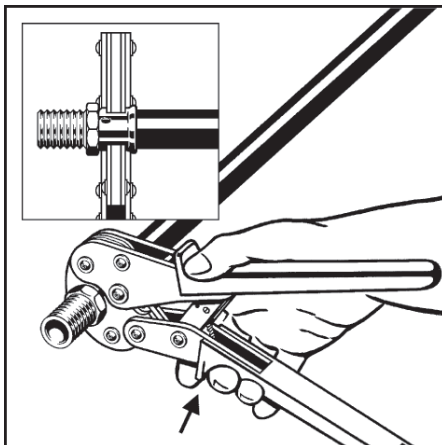

6. Engage press tool perpendicular over press sleeve and close tool jaws.

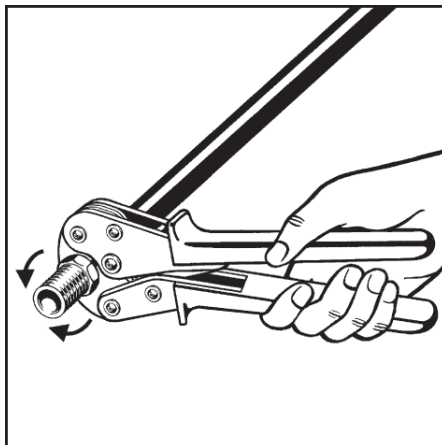

7. Start tool ratchet until automatic tool release occurs at proper compression force.

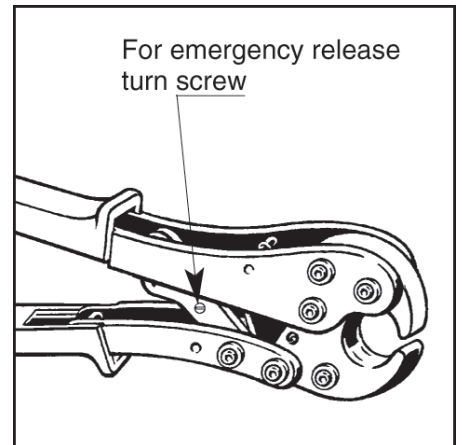

8. **Warning:** The connection is not leak-proof when the tool has been opened by emergency release.

Follow these steps each time you make a 5/16" - 5/8" compression connection.

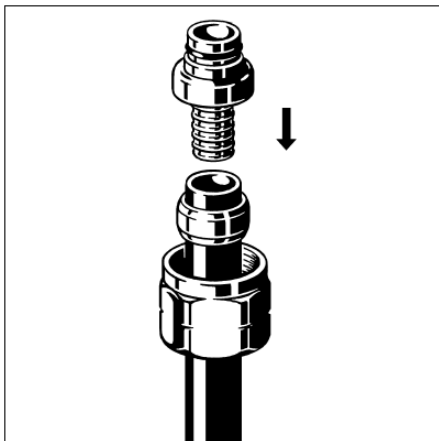

1. Square off end of tubing. Slide compression nut up tubing and slip brass ferrule over tubing.

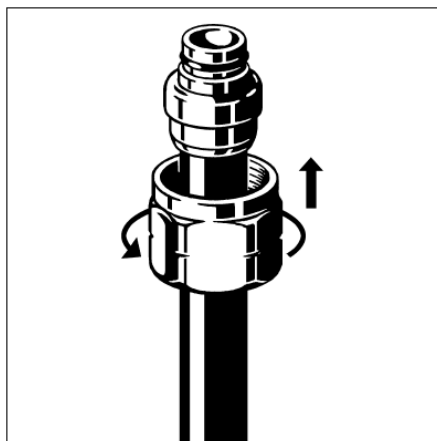

2. Slide tubing over end of SVC adapter, pushing it on fully until tubing is flush with shoulder of fitting.

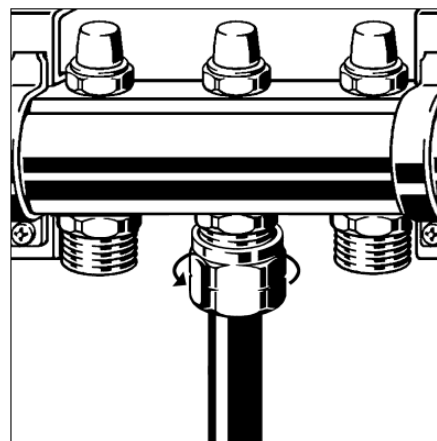

3. Insert SVC adapter into seat (manifold or other fitting) and tighten compression nut with wrench. Re-tighten compression nut slightly after 30 minutes.

## Piping a Mixing Station with a circulator installed in Boiler

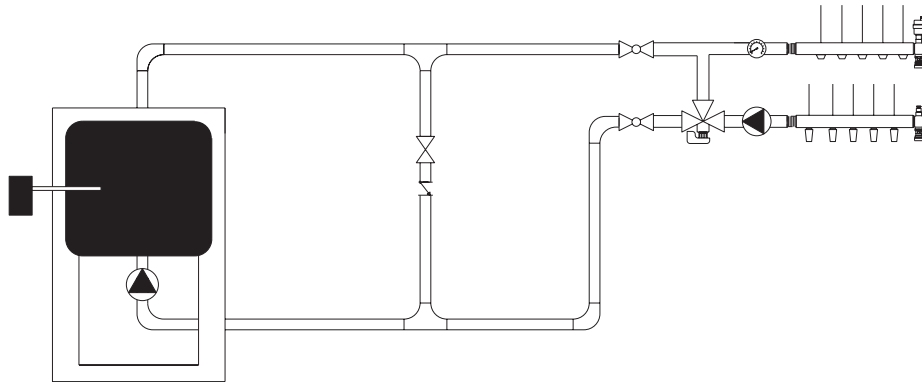

Figure Appendix B.a

## Piping of Mixing Stations for low and high temperature applications

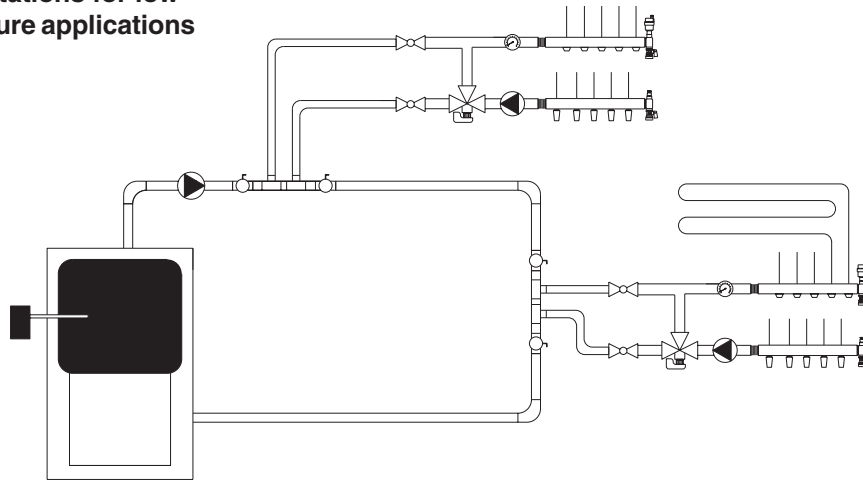

Figure Appendix B.b

## Piping a Mixing Station with Multiple Zone Baseboard or Radiators, Circulators on System Return.

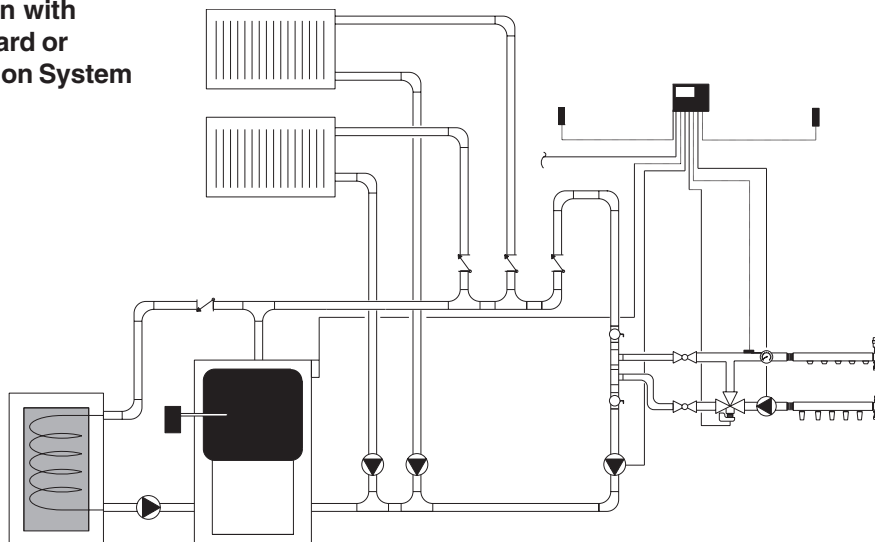

Figure Appendix B.c





## PUMP SIZING - APPENDIX C

### Combi-Flex Sizing: Pump Selection For 1/2" Pextron and FostaPex (Pressure Drop Through Tubing In Feet Of Head)

Btu/h	Flow Rate (gpm)	Total Feet of Baseboard (Pressure drop, ft of hd)	Total Tubing Length (ft)							
			25	50	75	100	125	150	175	200
10000	1	18 (0.07)	Low (1.0)	Low (1.9)	Low (2.9)	Low (3.8)	Low (4.8)	Low (5.7)	Low (6.7)	Low (7.6)
20000	2	36 (0.47)	Low (3.8)	Low (7.5)	Low (11.3)	Medium (15.0)	Medium (18.8)	Medium (22.5)	High (26.3)	
30000	3	54 (1.44)	Low (7.0)	Medium (14.0)	High (21.0)					
40000	4	72 (3.15)	Medium (11.0)	High (22.0)						

Table Appendix C.a

### Combi-Flex Sizing: Pump Selection For 3/4" Pextron and FostaPex (Pressure Drop Through Tubing In Feet Of Head)

Btu/h	Flow Rate (gpm)	Total Feet of Baseboard (Pressure drop, ft of hd)	Total Tubing Length (ft)							
			50	100	150	200	250	300	350	400
10000	1	18 (0.07)	Low (0.5)	Low (1.0)	Low (1.5)	Low (2.0)				
20000	2	36 (0.47)	Low (1.4)	Low (2.8)	Low (4.2)	Low (5.6)	Low (7.0)	Low (8.4)	Low (9.8)	Low (11.2)
30000	3	54 (1.44)	Low (2.8)	Low (5.5)	Low (8.3)	Low (11.0)	Medium (13.8)	Medium (16.5)	High (19.3)	High (22)
40000	4	72 (3.15)	Low (4.5)	Low (9.0)	Medium (13.5)	High (18.0)	High (22.5)			

Table Appendix C.b

### Combi-Flex Sizing: Pump Selection For 1" Pextron and FostaPex (Pressure Drop Through Tubing In Feet Of Head)

Btu/h	Flow Rate (gpm)	Total Feet of Baseboard (Pressure drop, ft of hd)	Total Tubing Length (ft)							
			50	100	150	200	250	300	350	400
10000	1	18 (0.07)	Low (0.1)	Low (0.2)	Low (0.4)	Low (0.5)	Low (0.6)	Low (0.7)	Low (0.8)	Low (0.9)
20000	2	36 (0.47)	Low (0.4)	Low (0.8)	Low (1.2)	Low (1.6)	Low (2.0)	Low (2.4)	Low (2.8)	Low (3.2)
30000	3	54 (1.44)	Low (0.8)	Low (1.6)	Low (2.4)	Low (3.3)	Low (4.1)	Low (4.9)	Low (5.7)	Low (6.5)
40000	4	72 (3.15)	Low (1.4)	Low (2.7)	Low (4.0)	Low (5.4)	Low (6.7)	Low (8.0)	Medium (9.4)	Medium (10.8)

Table Appendix C.c

Note: For 5/8" refer to page 8

**viega**

*One Company... One Partner... Delivering System Solutions.*

## Professional products and service for professional contractors

Rely on Viega North America for the most complete line of high tech/high quality plumbing, heating and snow melting systems... plus the most comprehensive customer support in the industry.



**viega**

**ProPress**  
SYSTEM

**viega**

**ProPressG**  
SYSTEM

**viega**

**PureFlow**  
SYSTEMS

**viega**

**ProRadiant**  
SYSTEMS

**viega**

**S-no-Ice**  
SYSTEM

**viega**

**SeaPress**  
SYSTEM

**Viega**  
301 N. Main, Floor 9  
Wichita, KS 67202  
PH: 1-877-VIEGA-NA FAX: 1-316-425-7618  
[www.viega.com](http://www.viega.com)  
[service@viega.com](mailto:service@viega.com)