

# Product Instructions

**viega**

## Diverting Valve

Three-Way Diverting Valves can be used for temperature control in many heating and snowmelting applications.

### Features

- Includes solder tailpieces (1-1/4" and 1-1/2" models use same valve body with different tailpieces)
- Pre-installed high limit kit
- Compatible with most Viega actuators
  - Three Position - 18003
  - Proportional Acuator - 0-10v 18025
  - Non-electric Models - 16101, 16102, 16104, 16105, 16115

### Specifications

Materials:

Bronze valve body  
Brass and corrosion-resistant steel  
internal components

EPDM rubber seals

Actuator threads: M30 x 1.0

Max working temp.: 242°F (120°C)

Max working pressure: 145 psi 10 bar)

Max differential pressure (tight shut-off on both end  
positions of valve discs):

3/4" 10.9 psi (75 kPa)

1" 7.3 psi (50 kPa)

1-1/4" 2.9 psi (20 kPa)

1-1/2" 2.9 psi (20 kPa)

### Operations

Diverting Valves have one entry port and two exit ports (see diagram to the right). Depending upon the position of the valve stem, flow is diverted from one exit port to the other.

**Valve Cross Section**

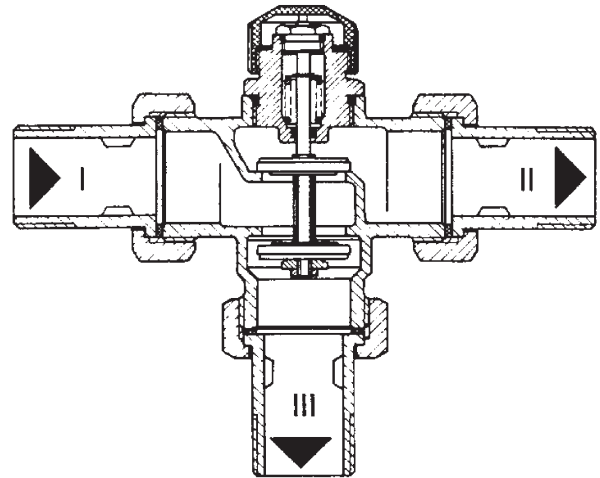

# Product Instructions

**viega**

## Pressure Drop / Dimensions

Pressure drop values and dimensions for Viega diverting valves may be determined from the chart below. 1-1/4" and 1-1/2" models share the same valve body, so the pressure drop for these models is the same.

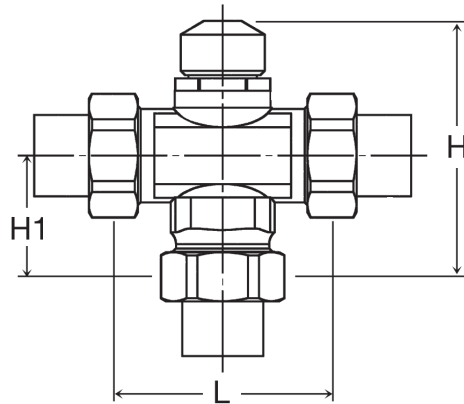

Stock Code	Size	Type	L (in)	H (in)	H1 (in)	Weight (lbs)	Cv Rating	Flow (gpm)	Heat Capacity (BTU/H)	Pressure Drop (psi)	Pressure Drop (ft of head)
20001	3/4"	Solder	3.15	3.94	1.85	2.2	5.3	5	50,000	0.9	2.0
								6	60,000	1.3	2.9
20002	1"	Solder	3.54	4.06	1.97	3	7.6	7	70,000	0.8	2.0
								9	90,000	1.4	3.2
20003	1-1/4"	Solder	4.53	4.65	2.52	6.1	11.1	10	100,000	0.8	1.9
								12	120,000	1.4	2.7
20041	1-1/2"	Solder	4.53	4.65	2.52	6.1	11.1	13	130,000	1.4	3.2
								14	140,000	1.6	3.7

Note: Heat capacity is based on water at a  $\Delta T$  of 20°F. The fluid used to calculate pressure drop across the valve is water @ 100°F

## Tailpiece Dimensions

### Soldered Tailpiece

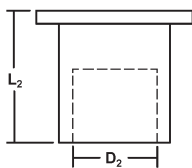

Size	D2 (in)	L2 (in)
3/4"	0.875	0.91
1"	1.125	1.18
1-1/4"	1.375	1.57
1-1/2"	1.625	1.26

### ProPress Tailpiece

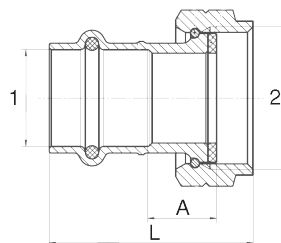

Stock Code	Size	A (in)	L (in)	G (in)
	1 2			
77764	1" x 1-1/4" BSP	0.72	0.41	2.04

# Product Instructions



## Piping Schematic of Basic Heating Control with Mixing Station and 3 Manifolds in Parallel

LEGEND: Mixing Station	
	Mixing Station
	Spring check
	Circulator
	Draw Off (Purge Valve)
	Make - Up Water
	Pressure Differential Bypass Valve
	Stainless Manifold w/ Flow Gauges
	Baseboard Zone (S)
	Diaphragm-Type Expansion Tank
	Zone Valve

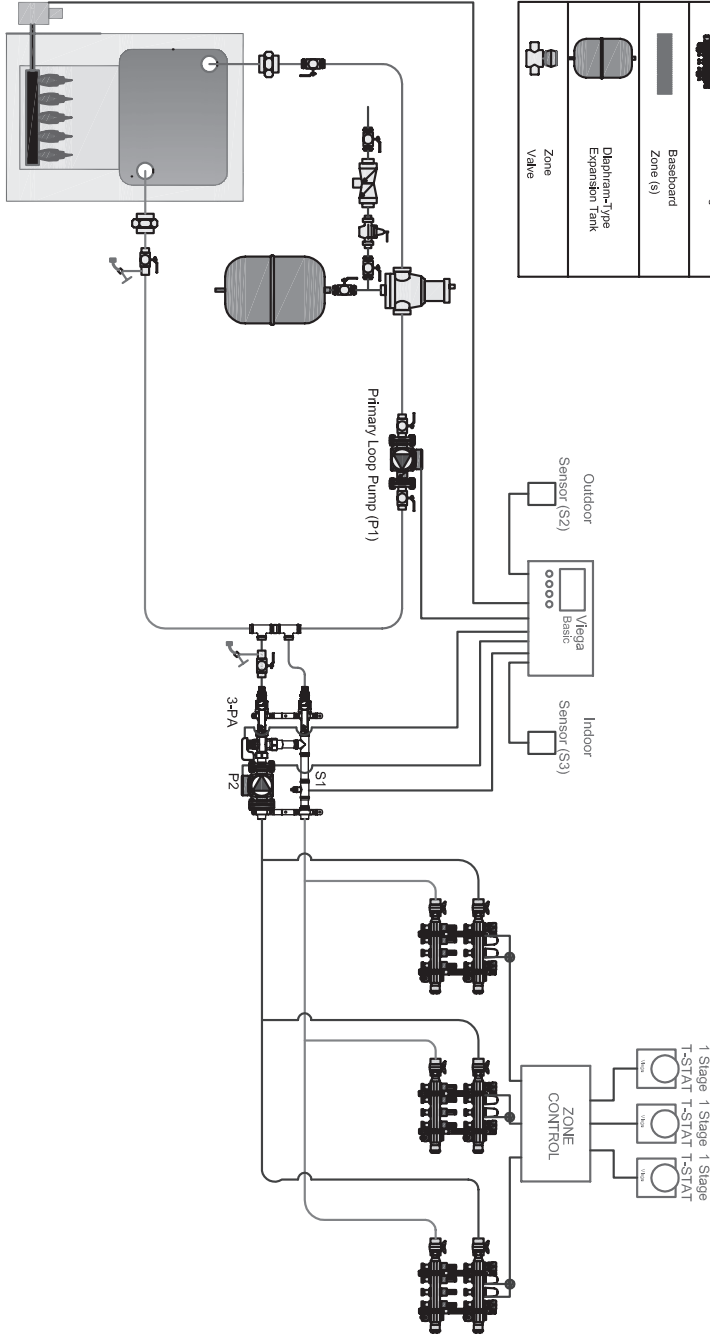

### NOTES: Piping

1. This drawing shows system piping concept only. Installer is responsible for all equipment & detailing required by local codes.
2. Size header piping for maximum flow velocity of 2 ft. / sec.
3. All other piping should be sized for a maximum flow velocity of 4 ft. / sec.
4. Install a minimum of 12 diameters of straight pipe upstream of all circulators and check valves.
5. Install isolating flanges or isolating valves on all circulators.
6. Install purging valve(s) on all circuits.
7. All closely spaced tees shall be within 4 pipe diameter center to center spacing.
8. Install minimum of 6 pipe diameters of straight pipe upstream and downstream of all closely spaced tees.
9. Differential pressure bypass valve prevents flow noise under partial load conditions (some zone valves closed).
10. Set differential pressure bypass valve to delta P of distribution system with all zones open + 1 psi
11. Not all components may be required depending on control strategy (i.e. constant circulation).

# Product Instructions



## Wiring Schematic of Basic Heating Control with Mixing Station and 3 Manifolds in Parallel

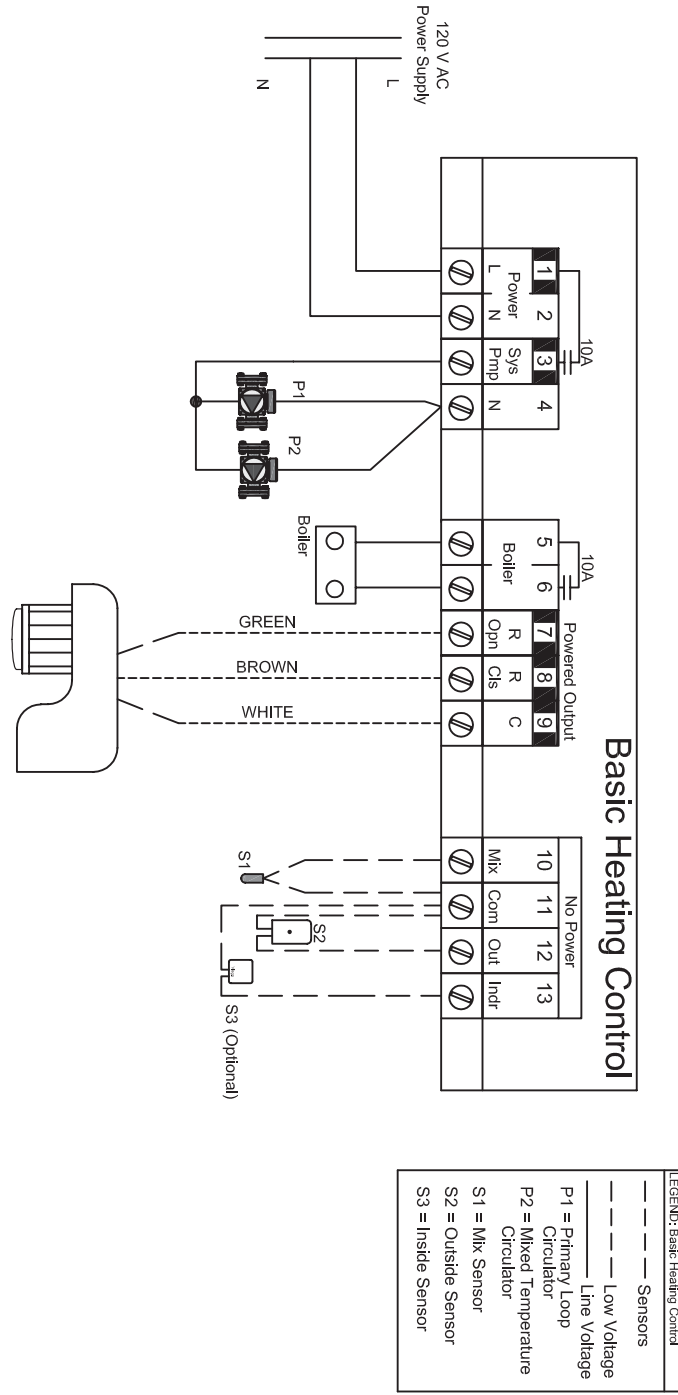

### NOTES: Wiring

1. This drawing shows system wiring concept only installer is responsible for all equipment & detailing required by local codes.
2. All wiring shall be in conformance with the latest edition of the National Electrical Code.
3. Maximum current rating of Basic and Advance Heating Control Relay is 10 Amps. Basic and Advance Snow Melting Control Relay is 5 Amps. Maximum current rating of Zone Control Relays is 5 Amps, if circulator draw exceeds this use pilot relay with 120 VAC coil operated by Viega Control.
4. Consult with control / boiler manufacturer for limitations and installation instructions
5. Do not run the wires parallel to telephone or power cables. If the sensor wires are located in an area with strong source of electromagnetic interference (EMI), shielded cable or twisted pair should be used or the wires can be run in a grounded metal conduit. If using shielded cable, the shield wire should be connected to the Com or Com Sen terminal on the control and not to earth ground. Use 18 AWG copper wiring for all sensor wiring. Sensors should be located 12" down stream of mixing point.
6. DHW priority relay must be rated to handle full amperage load of zone circulator relay center.
7. Other configurations are possible, but all space heating zone circulators must turn off when DHW mode is on or heat source needs to be sized for multiple loads.

# Product Instructions



## Piping Schematic of Basic Heating Control with Mixing Station, 3 Manifolds in Parallel and High Temp with Powerheads and Boiler Relay

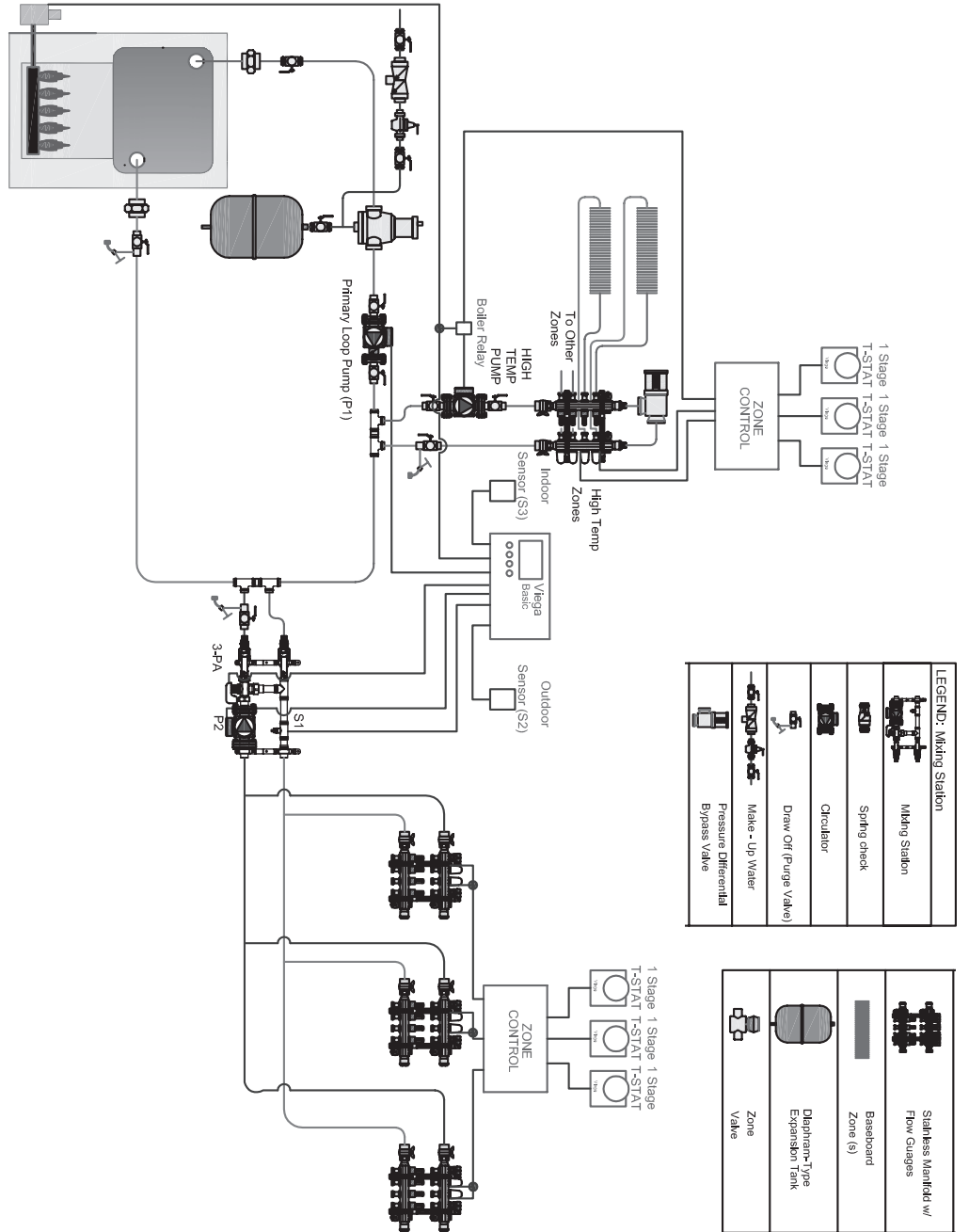

### NOTES: Piping

1. This drawing shows system piping concept only. Installer is responsible for all equipment & detailing required by local codes.
2. Size header piping for maximum flow velocity of 2 ft. / sec.
3. All other piping should be sized for a maximum flow velocity of 4 ft. / sec.
4. Install a minimum of 12 diameters of straight pipe upstream of all circulators and check valves.
5. Install isolating flanges or isolating valves on all circulators.
6. Install purging valve(s) on all circuits.
7. All closely spaced tees shall be within 4 pipe diameter center to center spacing.
8. Install minimum of 6 pipe diameters of straight pipe upstream and downstream of all closely spaced tees.
9. Differential pressure bypass valve prevents flow noise under partial load conditions (some zone valves closed).
10. Set differential pressure bypass valve to delta P of distribution system with all zones open + 1 psi
11. Not all components may be required depending on control strategy (i.e. constant circulation).

# Product Instructions



## Wiring Schematic of Basic Heating Control with Mixing Station, 3 Manifolds in Parallel and High Temp with Powerheads and Boiler Relay

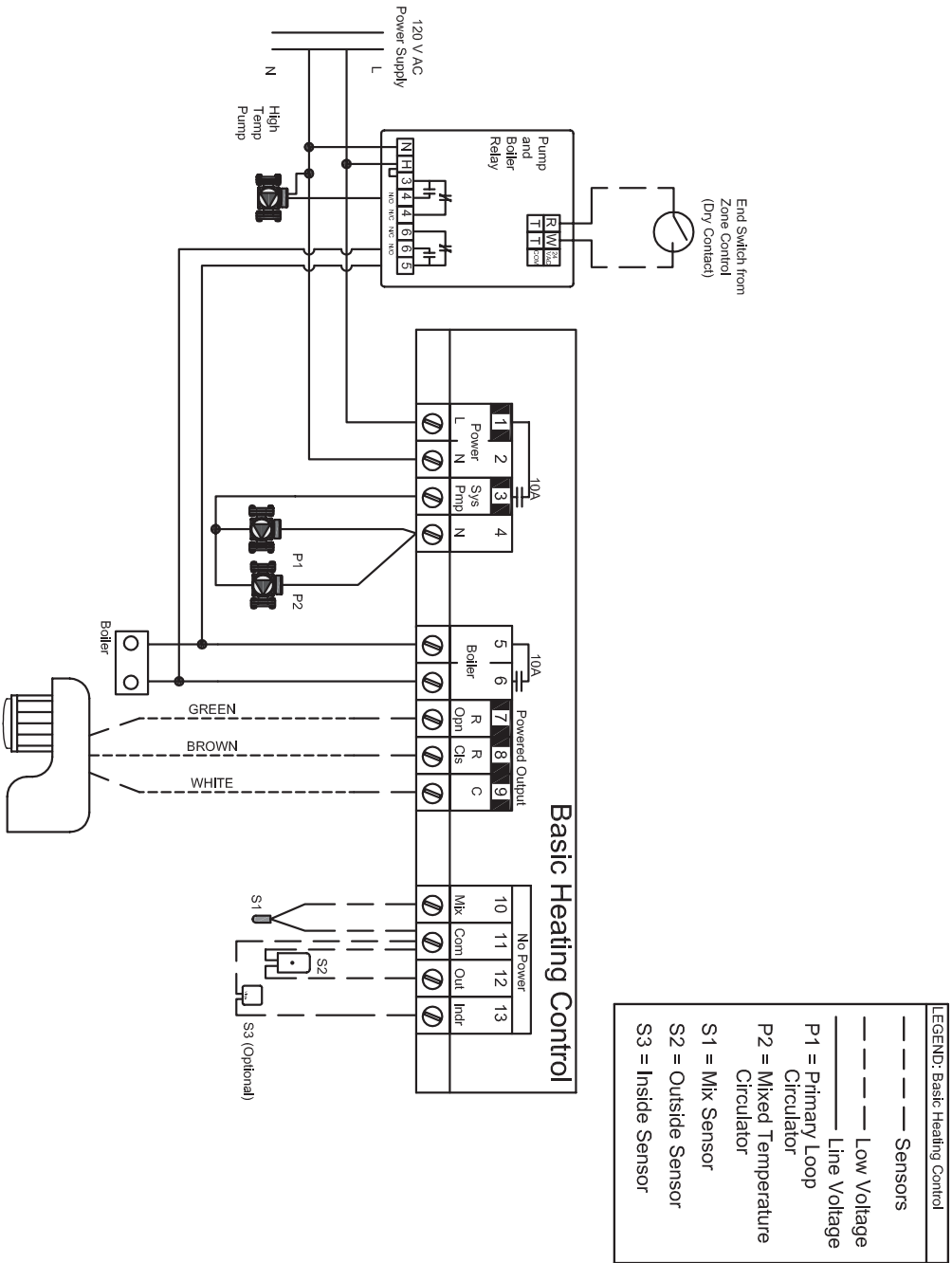

### NOTES: Wiring

1. This drawing shows system wiring concept only installer is responsible for all equipment & detailing required by local codes.
2. All wiring shall be in conformance with the latest edition of the National Electrical Code.
3. Maximum current rating of Basic and Advance Heating Control Relay is 10 Amps, Basic and Advance Snow Melting Control Relay is 5 Amps, Maximum current rating of Zone Control Relays is 5 Amps, if circulator draw exceeds this use pilot relay with 120 VAC coil operated by Viega Control.
4. Consult with control / boiler manufacturer for limitations and installation instructions
5. Do not run the wires parallel to telephone or power cables. If the sensor wires are located in an area with strong source of electromagnetic interference (EMI), shielded cable or twisted pair should be used or the wires can be run in a grounded metal conduit. If using shielded cable, the shield wire should be connected to the Com or Com Sen terminal on the control and not to earth ground. Use 18 AWG copper wiring for all sensor wiring. Sensors should be located 12" down stream of mixing point.
6. DHW priority relay must be rated to handle full amperage load of zone circulator relay center.
7. Other configurations are possible, but all space heating zone circulators must turn off when DHW mode is on or heat source needs to be sized for multiple loads.

# Product Instructions



## Piping Schematic of Basic Snow Melt Control with Non-Electric Control

LEGEND:	
	Diverging Valve with 3-Position Actuator
	3-way Mixing Valve and Motor
	4-way Mixing Valve and Motor
	Circulator
	Draw Off (Purge Valve)
	Back Flow Preventer
	Pressure Reducing Valve
	Flow Check Valve
	Swing Check Valve
	Pressure Differential Bypass Valve
	Stainless Manifold w/ Flow Gauges
	Baseboard Zone (S)
	Diaphragm-Type Expansion Tank
	Zone Valve
	Metered Balancing Valve

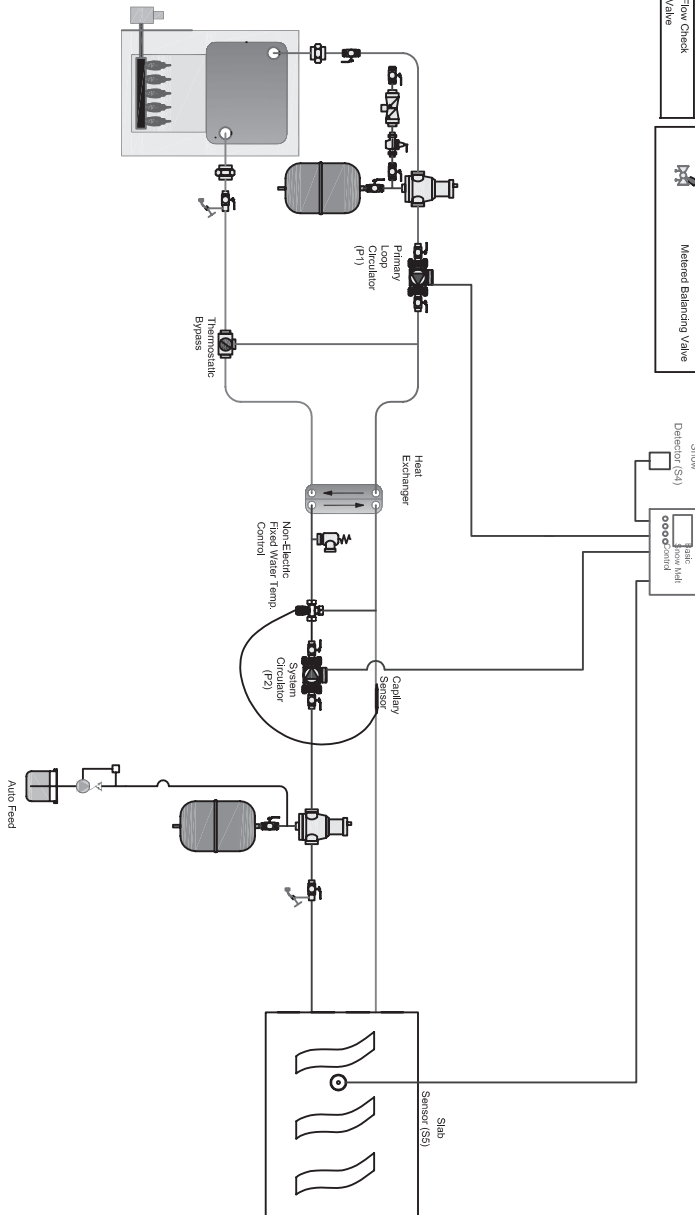

### NOTES: Piping

1. This drawing shows system piping concept only. Installer is responsible for all equipment & detailing required by local codes.
2. Size header piping for maximum flow velocity of 2 ft. / sec.
3. All other piping should be sized for a maximum flow velocity of 4 ft. / sec.
4. Install a minimum of 12 diameters of straight pipe upstream of all circulators and check valves.
5. Install isolating flanges or isolating valves on all circulators.
6. Install purging valve(s) on all circuits.
7. All closely spaced tees shall be within 4 pipe diameter center to center spacing.
8. Install minimum of 6 pipe diameters of straight pipe upstream and downstream of all closely spaced tees.
9. Differential pressure bypass valve prevents flow noise under partial load conditions (some zone valves closed).
10. Set differential pressure bypass valve to delta P of distribution system with all zones open + 1 psi
11. Not all components may be required depending on control strategy (i.e. constant circulation).

# Product Instructions



## Wiring Schematic of Basic Snow Melt Control with Non-Electric Control

- NOTES: Wiring**
1. This drawing shows system wiring concept only installer is responsible for all equipment & detailing required by local codes.
  2. All wiring shall be in conformance with the latest edition of the National Electrical Code.
  3. Maximum current rating of Basic and Advance Heating Control Relay is 10 Amps, Basic and Advance Snow Melting Control Relay is 5 Amps, Maximum current rating of Zone Control Relays is 5 Amps, if circulator draw exceeds this use pilot relay with 120 VAC coil operated by Viega Control.
  4. Consult with control / boiler manufacturer for limitations and installation instructions
  5. Do not run the wires parallel to telephone or power cables. If the sensor wires are located in an area with strong source of electromagnetic interference (EMI), shielded cable or twisted pair should be used or the wires can be run in a grounded metal conduit. If using shielded cable, the shield wire should be connected to the Com or Com Sen terminal on the control and not to earth ground. Use 18 AWG copper wiring for all sensor wiring. Sensors should be located 12" down stream of mixing point.
  6. DHW priority relay must be rated to handle full amperage load of zone circulator relay center.
  7. Other configurations are possible, but all space heating zone circulators must turn off when DHW mode is on or heat source needs to be sized for multiple loads.

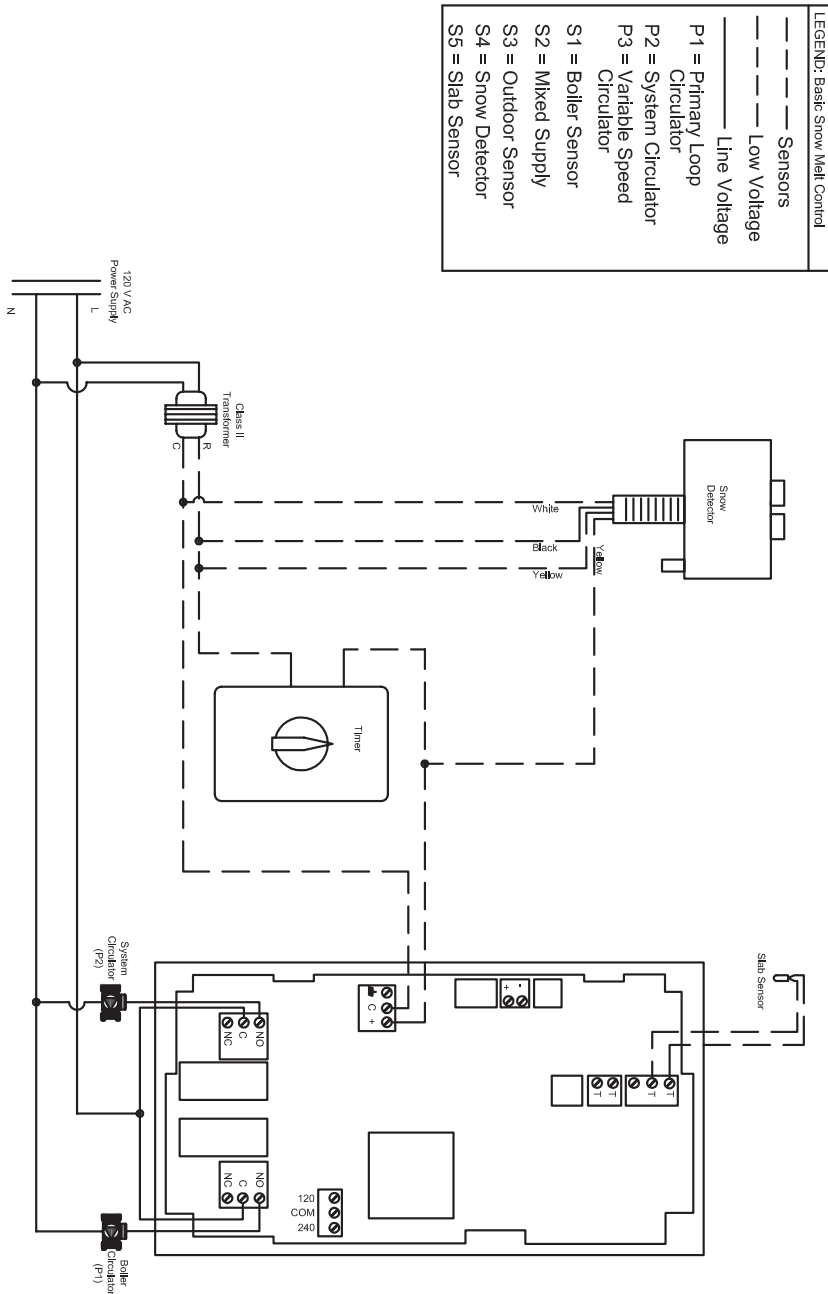



# Product Instructions

viEGA

## Installation

The Diverting Valve is provided with a pre-installed temperature High Limit Kit. This kit is installed into the 3-way valve to allow a maximum supply water temperature to be set. This kit must be unscrewed when purging the system and should then be set according to the instructions below.

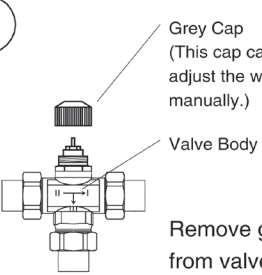
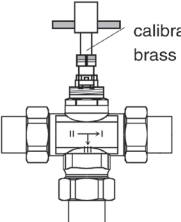
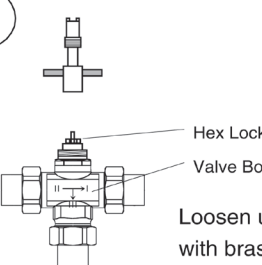
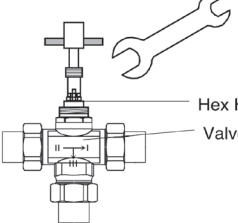
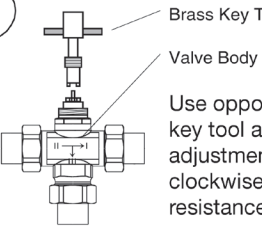
<p>1</p>  <p>Remove grey plastic cap from valve body.</p>	<p>4</p> <p>Note: This calibration must be done with the boiler at its highest temperature, the circulator running and all zones open.</p>  <p>Turn adjustment screw further clockwise until desired supply water temperature is obtained and count quarter turns for reference. This has to be done carefully and slowly because each quarter turn of the adjustment screw will result in approximately 15 °F temperature reduction. Wait until desired water temperature stays consistent.</p>
<p>2</p>  <p>Loosen up hex lock nut with brass key tool.</p>	<p>5</p>  <p>Tighten hex lock nut with wrench. Do not overtighten.</p> <p>To secure high limit adjustment, hold slotted adjustment screw with brass key while tightening lock nut.</p>
<p>3</p>  <p>Use opposite side of brass key tool and turn inner adjustment screw (slotted) clockwise until valve spring resistance is felt.</p> <p>To lower water temperature turn key clockwise; turn counterclockwise to raise it.</p>	

This document subject to updates. For the most current Viega technical literature please visit [www.viega.us](http://www.viega.us).  
Click Services -> Click Electronic Literature Downloads -> Select Product Line -> Select Desired Document

Para ver las instrucciones en español visite [www.viega.us](http://www.viega.us) -> Services -> Electronic Literature Downloads -> French and Spanish Documents -> Documento Deseado

Pour obtenir des instructions en français visite [www.viega.us](http://www.viega.us) -> Services -> Electronic Literature Downloads -> French and Spanish Documents -> Document Désiré

Viega LLC, 301 N. Main, 9th Floor • Wichita, KS 67202 • Ph: 800-976-9819 • Fax: 316-425-7618