

Installation and Service Instructions

Low Emissions Blue Flame Oil Burner

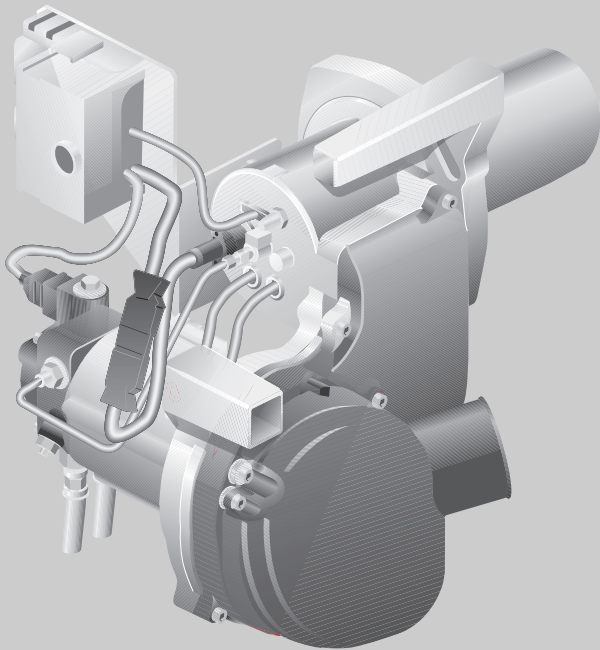

Notice! This manual must be retained for future reference.

CAUTION!

Read this manual carefully before putting this burner into operation.

WARNING!

This burner requires special training and a specific tool kit. Do not attempt installation and/or service unless you are a Buderus trained and certified technician equipped with the proper tools and measurement equipment.

Improper installation, adjustment, alteration, service or maintenance can cause property damage, personal injury, or loss of life. Refer to this manual.

For assistance or additional information consult a Buderus trained installer, service agency or oil company.

CAUTION!

The operating manual is part of the documentation that is delivered to the installation's operator. Go through the information in this manual with the owner/operator and make sure that he or she is familiar with all the necessary operating instructions.

Logatop BE 1.3 and 2.3

For trained installers

Read carefully prior to installation, maintenance and service.

Buderus

1	General Instructions	4
1.1	Codes and standards	4
1.1.1	Certification	4
1.1.2	United States installations	4
1.1.3	Canadian Installations	4
2	Safety	5
2.1	Regarding this manual	5
2.2	Intended use	5
2.3	Notes structure	5
2.4	Important safety information	6
2.5	Disposal	7
3	Product description	8
4	Technical data and scope of delivery	9
4.1	Burnertypes	9
4.2	Burner tubes	10
4.3	Settings and nozzle specification	10
4.4	Auto digital burner controller LMO	11
4.5	Scope of Delivery	11
5	Conducting service work on the automated primary burner controller LMO	12
5.1	Program sequence	12
5.2	Operating automated burner controller LMO	13
5.3	Repairing faults in the automated burner controller LMO	14
6	Initial burner start-up	15
6.1	Checking electrical plug connections	15
6.2	Establishing combustion air pipe connection	15
6.3	Checking and connecting oil lines	15
6.4	Bleeding oil line	16
6.5	Starting the Burner	17
6.6	Tightening burner door retaining screws	18
6.7	Adjusting the burner	18
6.7.1	Recording measured values	18
6.7.2	Measuring CO ₂ -value	19
6.7.3	Fine tuning the CO ₂ -Value	20
6.7.4	Measuring CO content (carbon monoxide)	21
6.7.5	Measuring chimney draft	21
6.7.6	Run particle test	21
6.8	Carrying out safety test	22
6.9	Installation protocol	23

7	Burner start-up and maintenance	24
7.1	Record and correct burner measurement values	24
7.2	Inspecting burner hood and burner	24
7.3	Verify burner motor operation	25
7.4	Shutting off the burner	25
7.5	Clean oil pump	25
7.6	Check fan housing for contamination and damage	26
7.6.1	Minor dust or contamination	26
7.6.2	More significant contamination	26
7.7	Checking ignition electrodes, mixing system, gasket, nozzle, and burner tube	27
7.7.1	Check electrodes and replace as needed	27
7.7.2	Check the mixing system (replace as needed)	27
7.7.3	Replacement of oil nozzle	28
7.7.4	Checking the shut-off valve in the oil pre-heater	29
7.7.5	Inspecting the burner tube	29
7.7.6	Burner installation and checking of burner gasket	30
7.8	Securing boiler door bolts	30
7.9	Check electrical connections	30
7.10	Conducting the safety test	31
7.11	Inspections and maintenance protocol	32
8	Additional service tests	34
8.1	Measurement of the flame sensor current	34
8.2	Verifying tightness of fireside heating surfaces	35
8.2.1	Establishing the upper limit	35
8.2.2	Performing tests in the combustion chamber	35
9	Layout of oil supply system	36
9.1	Installation of the oil filter	36
9.2	Sizing the oil supply lines	37
9.3	Testing for oil line vacuum	37
9.4	Testing Integrity of oil supply line	38
9.5	Use of vacuum valve	38
10	Troubleshooting burner failures	39
10.1	Functional diagram	39
10.2	Burner failure - reasons and solutions	40
11	Spare part listing	42
12	Glossary	52

1 General Instructions



NOTICE

It is the installer's and service personnel's responsibility to follow all applicable national and local codes and regulations.

Country	All Countries
Fuel	#2 Fuel Oil ASTM D396-05 Type 2
Comments	No other fuel may be used with this burner. Burner requires annual service and cleaning. Verify each time that the complete heating system is in working order. Defects must be remedied immediately.

Table 1 Permitted fuel types

1.1 Codes and standards

1.1.1 Certification

BE- burners are CSA listed for the U.S. and Canada, certified to comply with ANSI/UL 296 and CSA B140.2.1, for use with #2 heating oil (per standard ASTM D396).

Burner labels list compliance, where required, with special local, state or provincial approvals.



NOTICE

Install this burner in accordance with all local codes and authorities having jurisdiction. Regulations of these authorities take precedence over the general instructions provided in this manual.

1.1.2 United States installations

Burner/appliance installations in the United States must comply with the latest revisions of NFPA 31 (Standard for the Installation of Oil-Burning Equipment), ANSI/NFPA 70 (National Electrical Code), and all applicable local codes. **In the commonwealth of Massachusetts, 527 CMR 31.00** requires owners of all residential properties to install and maintain carbon monoxide (CO) alarms.

1.1.3 Canadian Installations

Burner/appliance installations in Canada must comply with the latest revision of CSA B139 (Installation Code for Oil Burning Equipment), CSA standard C22, Part 1 (Canadian Electrical Code), and all applicable local codes.

2 Safety

2.1 Regarding this manual

This document contains important information regarding safe and proper installation, operation, maintenance and troubleshooting of the blue flame burner Logatop BE 1.3 and 2.3.

The Installation and Maintenance Instructions are directed at the installing contractor who has professional knowledge of fuel oil powered heating boilers.

The Logatop BE 1.3 and 2.3 blue burners are referred as "burners" in this document.

For your own safety, observe these instructions.

2.2 Intended use

The burner must be installed in the Logano G125 BE boiler series.

The fully automatic burner complies with the specifications of UL-296 (burner) and UL-726 (boiler).

The burner is heat-tested at the factory and preset for the specified nominal boiler output (see label on burner). This means that it is only necessary to verify the burner settings at initial start-up and adjust for the local conditions if necessary.

2.3 Notes structure

Two danger levels are identified and signified by the following terms:



WARNING!

DANGER TO LIFE

Identifies possible dangers emanating from a product, which might lead to serious injury or death if appropriate care is not taken.



CAUTION!

DANGER OF INJURY/SYSTEM DAMAGE

Identifies potentially dangerous situations, which might lead to medium or slight injuries or material losses.

Additional symbols for identification of dangers and user instructions:



WARNING!

DANGER TO LIFE

from electric shock.



NOTICE

Tip for optimum use of equipment and adjustment as well as useful information.

2.4 Important safety information

If required by applicable regulations, the heating system has to comply with ANSI/ASME CSD-1 (Standard for Controls and Safety Devices for Automatically Fired Boilers).

Carbon monoxide detectors must be installed if required by applicable regulations.



DANGER TO LIFE

from poisonous gases.

WARNING!

Insufficient combustion air can cause dangerous flue gas leaks.

- The ventilation and exhaust openings must never be plugged. The cross-section of the ventilation and exhaust openings must comply with the design specifications at all times.
- If the ventilation and exhaust openings do not comply with the specifications, the heating system must never be operated.
- Notify operator and building owner of the defect in writing.



FIRE DANGER

from flammable material or liquids.

WARNING!

- Make sure that there is no combustible material or liquids in the boiler room before starting work.



FIRE DANGER

from unintended use.

WARNING!

- The burner may only be operated while installed in a boiler.



BURNER DAMAGE

from contaminated combustion air.

CAUTION!

- Prevent excessive dust levels.



CAUTION!

SYSTEM DAMAGE

from blocked oil filters.

Filters that clog up immediately after filling a tank may indicate that residue from the bottom was stirred up.

- In such cases it is recommended to shut down the heating system while filling the tank and wait several hours before restarting the system. Instruct the operator and building owners accordingly.



CAUTION!

SYSTEM DAMAGE

From improper installation

- Always follow state of the art construction techniques for installation and maintenance, and observe all applicable codes and regulations.



WARNING!

DANGER TO LIFE

from electrical shock.

- Do not work on electrical components unless you have the required qualification.
- Before you start working, disconnect the heating system from electrical power by shutting off the emergency shutoff switch, or the heating system circuit breaker.
- It is not sufficient to simply shut off the controls.
- Observe all applicable codes and regulations.



CAUTION!

DEVICE DAMAGE

from incorrect repair.

- Do not attempt to repair parts that have built in safety features. Always replace the part.



NOTICE

- Only use original Buderus spare parts.
- Buderus does not accept responsibility for damage caused by third party spare parts.

**WARNING!****DANGER TO LIFE**

from neglecting ones own safety in case of emergency.

- Safety first. Never risk your life.

**CAUTION!****SYSTEM DAMAGE**

From insufficient maintenance.

- Perform maintenance annually. Check the complete heating system for defects and malfunction.
- Mitigate defects immediately to avoid larger scale system damage.

2.5 Disposal

- Dispose of packaging material in an environmentally responsible manner.
- Components of the heating system must be disposed of according to local regulations.

3 Product description

The main components of the burner are:

- Oil pump with solenoid valve and oil connection hoses (Fig. 1, **Item 1**)
- Burner motor (Fig. 1, **Item 2**)
- Burner tube (Fig. 1, **Item 3**)
- Automated burner controller with reset button (Fig. 1, **Item 5**)
- Flame sensor (Fig. 1, **Item 6**)
- Blower (Fig. 1, **Item 7**)

The burner (Fig. 1) is directly connected to the heating system control using the provided burner cable (7-pin burner plug Fig. 3, **Item 4**).

The burner is operated and monitored by the fully automated primary burner controller.

- After a demand for heat has been generated by the heating system control, the burner is switched on and the oil in the nozzle is heated to approximately 150° F. From a cold start the process may take a maximum of three minutes.
- After the oil has been heated, the fan and pump are energized, the solenoid valve is opened, and power supplied to the igniter.
- A blue flame is visible immediately after ignition.
- This combustion system vaporizes the oil using recirculation of hot gases, mixing them homogenously with the combustion air and burning them inside the burner tube.
- The flame sensor must send a flame signal before the safety period expires; otherwise the system will be switched off. (see Chapter 6.8 „Carrying out safety test“, page 22)

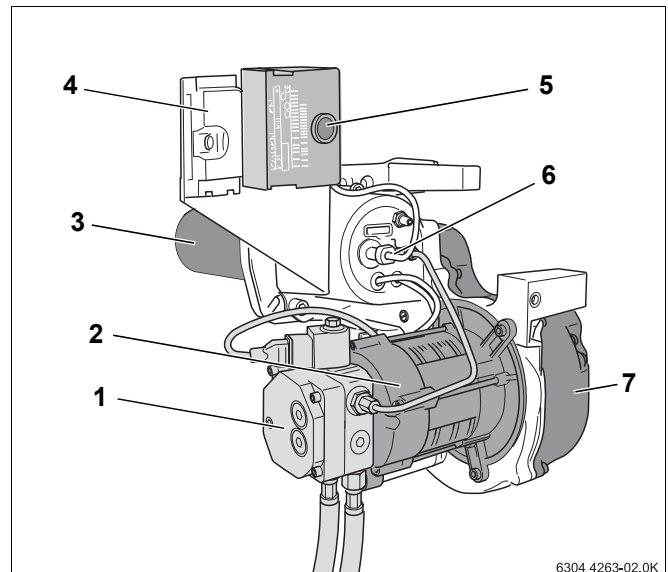

Fig. 1 Logatop BE 1.3 and 2.3 Burner

- Item 1:** Oil pump with solenoid valve and oil connection hoses
- Item 2:** Burner motor
- Item 3:** Burner tube
- Item 4:** Burner connection for 7-pin burner cable
- Item 5:** Automated burner controller with reset button
- Item 6:** Flame sensor
- Item 7:** Blower

4 Technical data and scope of delivery

The technical data provide information on the output profile of the burner.

4.1 Burnertypes

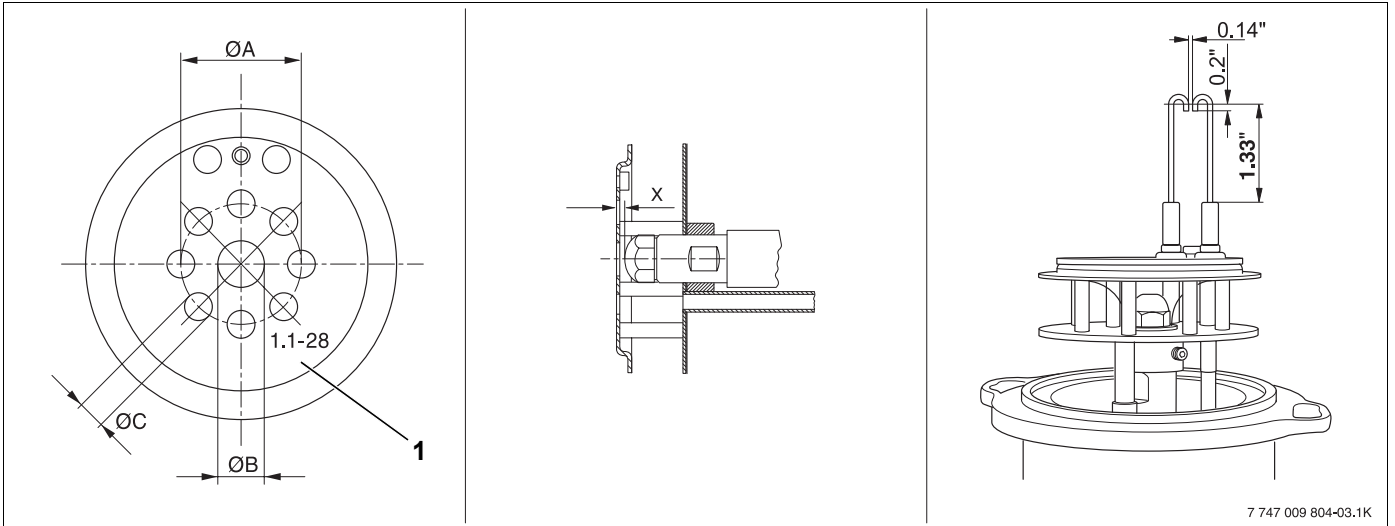

Fig. 2 Mixing system – Ø A, B, C

Fig. 3 Mixing system – dimension „X“

Fig. 4 Ignition electrode (dimension in inches)

Item 1: Stamp

Boiler	Burner	Stamp	Mixing system			
			4 A in inches	4 B in inches	4 C in inches	X in inches
Logano G125	BE 1.3 – 21	1.1 – 21	1 3/32	15/32	15/64	5/64
	BE 2.3 – 28	1.1 – 28	1 9/32	31/64	9/32	5/64
	BE 2.3 – 34	2.1 – 34	1 9/32	31/64	5/16	5/64

Table 2 Technical data– mixing system and ignition electrode

4.2 Burner tubes

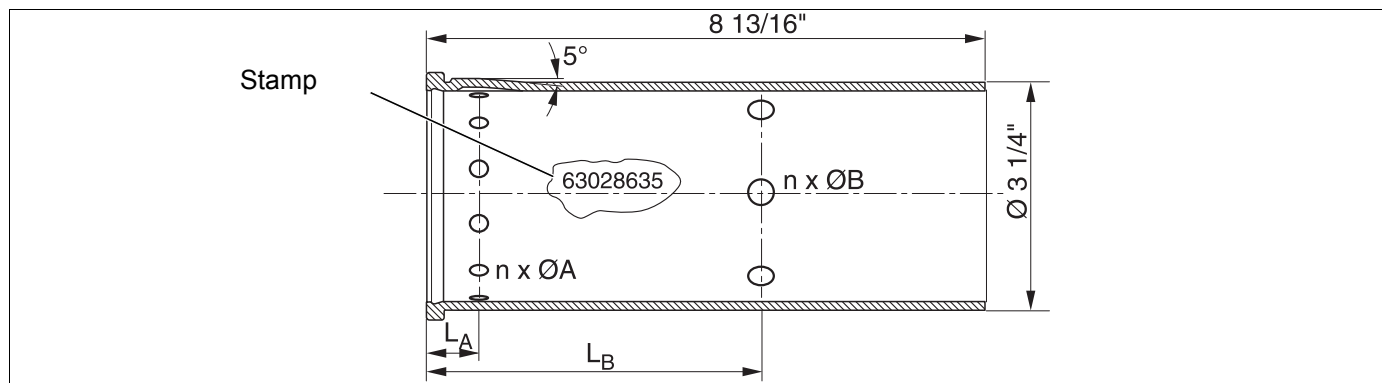

Fig. 5 Dimensions of burner tube

Burner Logatop	Stamp	Tube	n x 4 A * in inch	n x 4 B * in inch	LA in inch	LB in inch
BE 1.3 - 21	63028636	D83/L224/4,3/2,6	12 x 0.17	6 x 0.1	0.71	3
BE 2.3 - 28	63028637	D83/L224/5,9/4,8	12 x 0.17	6 x 0.1	0.71	3
BE 2.3 - 34	63028638	D83/L224/7,0/5,7	12 x 0.17	6 x 0.1	0.71	3

Table 3 Ceramic burner tubes and their dimensions

* Tolerances of all measurements are -1/16"

4.3 Settings and nozzle specification



NOTICE

Specification is based on an intake air temperature of 68 °F and an installation below 1650 ft. elevation (see Chapter 6.7.2 „Measuring CO₂-value“, page 19).

Atmospheric combustion

Settings, nozzle installation ¹		G125 BE atmospheric combustion		
Burner type		BE 1.3 – 21	BE 2.3 – 28	BE 2.3 – 34
Output	MBtu/h	72	96	116
Mixing system		1.1 – 21	1.1 – 28	2.1 – 34
Nozzle ¹		Danfoss 0.45 gph 80° HFD	Danfoss 0.55 gph 60° HFD	Danfoss 0.65 gph 80° HFD
Oil pressure	psi	189 – 290	218 – 334	218 – 334
Oil	gph	0.58	0.76	0.95
Air intake setting (estimated)		4.5	5.5	5.5
Static air pressure		3.8 – 4.4	3.8 – 4.4	3.8 – 4.5
Combustion chamber pressure	W. C. [inch H ₂ O]	0 – 0.15	0 – 0.16	0 – 0.24
Min draft (required draft) ²		0	0	0
Available draft		0.12	0.12	0.12
CO ₂ -without hose connected	%	13.0 – 13.5	13.0 – 13.5	13.0 – 13.5
CO ₂ -with hose connected	%	13.5 – 14.0	13.5 – 14.0	13.5 – 14.0
CO-Value	ppm	< 50	< 50	< 50

Table 4 Settings and nozzle installation for G125 BE with atmospheric combustion

¹ Recommended: use only the nozzle types specified here.

² In chimney systems with negative pressure.

Sealed combustion

Settings, nozzle installation ¹		G125 BE sealed combustion		
Burner type		BE 1.3 – 21	BE 2.3 – 28	BE 2.3 – 34
Output	MBtu/h	72	96	116
Mixing system		1.1 – 21	1.1 – 28	2.1 – 34
Nozzle ¹		Danfoss 0.45 gph 80° HFD	Danfoss 0.55 gph 60° HFD	Danfoss 0.65 gph 80° HFD
Oil pressure	psi	189 – 290	218 – 334	218 – 334
Oil	gph	0.58	0.76	0.95
Air intake setting		4.5	5.5	5.5
Static air pressure	W. C. [inch H ₂ O]	3.8–4.4	3.8–4.4	3.8–4.5
Combustion chamber pressure		0 – 0.15	0 – 0.16	0 – 0.24
Min draft (required draft) ²		0	0	0
Available draft		0.12	0.12	0.12
CO ₂ -without hood	%	Fig. 16, page 20		
CO ₂ -with hood	%	Fig. 16, page 20		
CO-value	ppm	< 50	< 50	< 50

Table 5 Settings and nozzle installation for G125 BE with sealed combustion

¹ Recommended: use only the nozzle types specified here.

² In chimney systems with negative pressure.

4.4 Auto digital burner controller LMO

LMO		
Supply voltage	V, AC	120
Frequency	Hz	60
External fuse	A	6.3
Wattage	VA	12
Weight	lbs	ca. 0.5
Protection		IP 40

Table 6 Technical specifications LMO

4.5 Scope of Delivery

- Verify that the packaging is not damaged on arrival.
- Verify that the delivery is complete.



NOTICE

The burner is supplied as a complete unit with the boiler, the burner door, the panels and the front boiler cover.

5 Conducting service work on the automated primary burner controller LMO

The LMO operates and monitors the burner at all times.

The flame is monitored by a blue-flame sensor. The LMO receives a heat demand from the heating system control or boiler Aquasmart control.

In case of a fault the reset button (Fig. 6, **Item 1**) on the LMO allows troubleshooting (see Chapter 5.3 „Repairing faults in the automated burner controller LMO“, page 14).



DANGER TO LIFE

from electric shock.

WARNUNG!

- Never open the automated burner controller LMO and never attempt repair or modifications.
- Never operate the unit after the LMO has been dropped or taken a hit. Safety functions may be affected even if there is no visible damage.

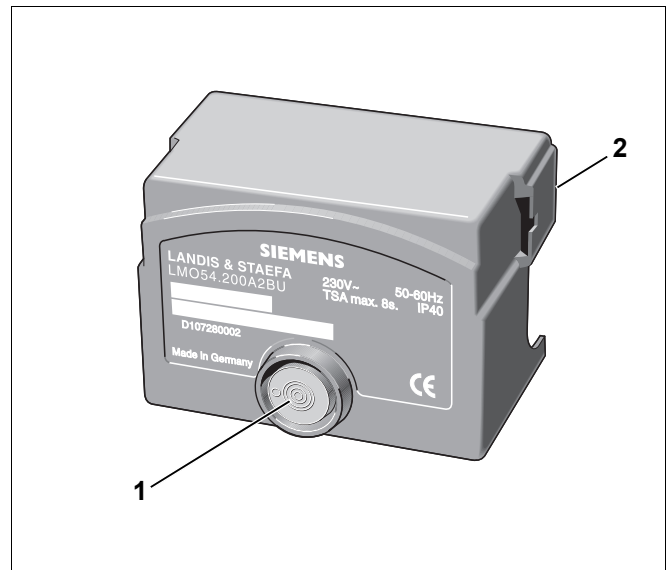

Fig. 6 Automated burner controller LMO

Item 1: Three color indicator light and Reset button

Item 2: Latch to release

5.1 Program sequence

Legend:

- R** Temperature and pressure control
- W** Temperature and pressure monitor
- SB** Safety limiter
- OH** Oil pre-heater
- OW** : Oil pre-heater activation
- M** : Burner motor
- BV1** : Solenoid valve 1
- Z** : Ignition transformer
- FS** : Flame signal
- LED** : 3-color indicator light
- tw** : Wait time
- t1'** : Ventilation time
- t1** : Pre-ventilation time
- t3** : Pre-ignition time
- t3n** : Post-ignition time
- TSA** : Start-up safety time
- A'** : Start of operation in burner with "OH"
- A** : Start of operation in burner without "OH"
- B** : Time of flame formation
- C** : Operating position
- D** : Control shutoff by "R"

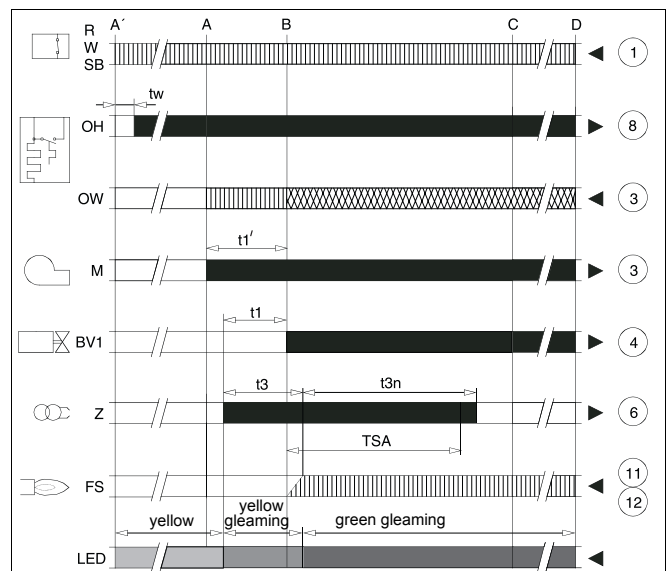

Fig. 7 Automated burner controller program sequence

■ = control signals

||||| = required input signals

▨ = allowed input signals

5.3 Repairing faults in the automated burner controller LMO

After a fault shut off the burner, the LED on the automated burner controller LMO will light red. The faults can be identified by observing a flash code.

Proceed as follows:

- Press reset button for 5 seconds until the LED briefly flashes yellow.
- Observe the flash code and find the type of the fault in the table (Table 8).
- Press reset button for one second to stop the diagnosis and to unlock the burner.

Flash code	Possible cause	Correction
2 x flash	no flame formed during safety time	Troubleshooting (see Chapter 10 „Troubleshooting burner failures“, page 39).
4 x flash	Stray light at burner start	
7 x flash	Flame goes out during operation	
8 x flash	oil pre-heater time monitoring	First check electrical connections. Next step replace oil pre-heater.
10 x flash	Internal error Wiring fault	Unlock LMO (Press reset button for one second). Next step, replace LMO.
LED "flickers" RED	Interface mode is active	Activate interface diagnosis by pressing the reset button for five seconds. If the diagnosis has been accidentally activated (LED "flickers" red), it can be switched off by pressing the reset button again for five seconds. It signals the mode change by a yellow flash.

Table 8 Diagnosing faults



NOTICE

The control outputs are deactivated and the burner remains off while diagnosing faults.

6 Initial burner start-up

This chapter describes how to start the burner for the first time. The burner has been factory-fired, and set up at the factory for room air independent operation. Verify if the factory settings are acceptable for the installation, and only adjust if required due to system specification.

- Then complete the inspection log (see Chapter 6.9 „Installation protocol“, page 23).



NOTICE

For safety reasons the burner is supplied in "lock out status".

6.1 Checking electrical plug connections

- Verify that all electrical plug connections are correctly installed.

6.2 Establishing combustion air pipe connection

In sealed combustion installations the flexible hose is connected to the air intake in the blower housing.

- Attach the flexible hose using the supplied hose clamp.

6.3 Checking and connecting oil lines

Before connecting the oil supply to the burner, check that all oil lines and the oil filter are clean and tight.

- Inspect the oil lines including all components and clean or replace if necessary.
- Check oil filter, replace if previously used.
- Check oil supply system (see Chapter 9 „Layout of oil supply system“, page 36).
- Connect burner oil hoses to a Tigerloop (supplied).



NOTICE

Be careful not to reverse the suction and return lines (Fig. 8).

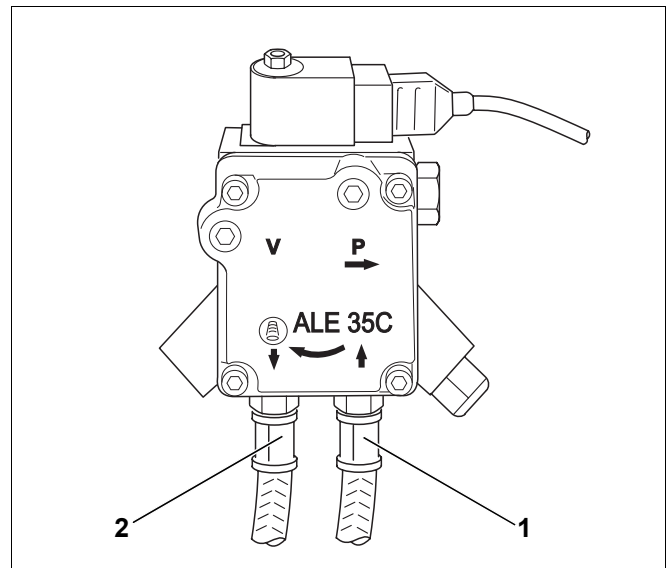

Fig. 8 Oil pump – Suntec

Item 1: Oil suction line (red stripe)

Item 2: Return line (blue stripe)

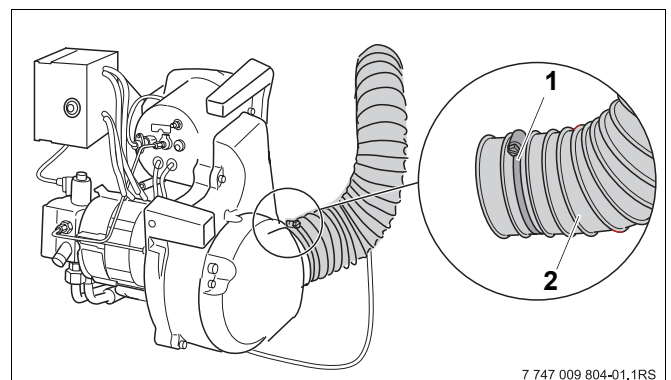

Fig. 9 Connecting flexible hose to burner

Item 1: Supplied hose clamp

Item 2: Flexible combustion air hose

7 747 009 804-01.1RS

6.4 Bleeding oil line

The oil supply system must be checked to ensure that the burner will operate properly (see Chapter 9 „Layout of oil supply system“, page 36). Check the suction resistance and inspect for leaks, particularly in retrofit systems.

There are two methods for bleeding the oil line:

- Oil suction pump – this will prevent damage to the oil pump caused by running dry.
- Burner tester (Fig. 11, **Item 1**; Accessory) – if the burner oil pump is to supply the oil.

The procedure for bleeding the oil line with the burner tester (Fig. 11, **Item 1**) is described below.

- Disconnect the heating system from the electric power.
- Remove automated burner controller (Fig. 10, **Item 2**) from its base.
- Plug burner tester (Fig. 11, **Item 1**) into the base.
- Switch ON power to the heating system.
- Switch on control mode switch. The LED (red) lights (Fig. 11, **Item 2**).
- Switch on burner tester with the mode switch (Fig. 11, **Item 5**). Both LEDs (red and green) light (Fig. 11, **Item 2 and 3**).
- Switch on oil preheater (Fig. 11, **Item 4**) switch.



SYSTEM DAMAGE

from a defective oil pump.

CAUTION!

- Never run the pump without oil longer than five minutes.

- Check that the oil in the Tigerloop reservoir (Fig. 10, **Item 4**) is free from bubbles.

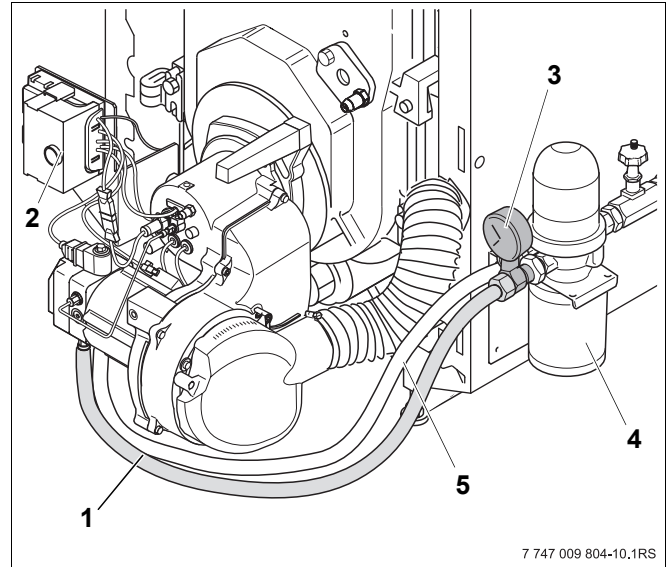

Fig. 10 Oil filter, vacuum meter and transparent hose

Item 1: Oil suction line

Item 2: Automated burner controller

Item 3: Vacuum meter

Item 4: Tigerloop

Item 5: Oil return line

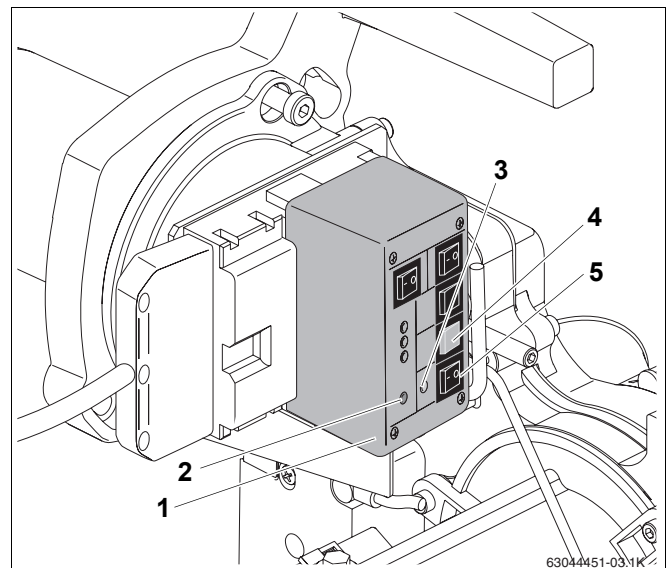

Fig. 11 Bleeding oil line with burner tester

Item 1: Burner tester

Item 2: LED (red)

Item 3: LED (green)

Item 4: Switch for running the oil preheater

Item 5: Burner tester switch

**SYSTEM DAMAGE**

from frequent resets.

CAUTION!

If the burner is reset more than three times in quick succession (within three minutes) without consequential ignition, the burner ignition transformer may be damaged.

- Bleed the system using an external oil pump, not by repeatedly pressing the reset button (Fig. 12, **Item 1**).

6.5 Starting the Burner

- Disconnect your heating system from electric power.
- Close oil valve (Fig. 10, **Item 5**, page 16) and remove transparent hose (Fig. 10, **Item 4**, page 16) and vacuum meter (Fig. 10, **Item 3**, page 16).
- Screw oil suction line (Fig. 10, **Item 1**, page 16) to the filter connection of the Tigerloop (Fig. 10, **Item 5**, page 16).
- Open oil valve at oil filter (Fig. 10, **Item 5**, page 16).
- Switch ON power to the heating system.

**NOTICE**

The burner is in fault setting when delivered (the reset button LED is permanently red). The burner must first be reset.

- Press and hold reset button (Fig. 12, **Item 1**) for at least one second (switch on). The burner will be reset to start or operating mode after about five seconds (see Table 7, „Display of burner operating status by multicolor LED“, page 13).

**NOTICE**

Before every start (switch-on) the automatic burner controls runs through a self-test (about five seconds).

- Check oil connections for leaks.

If the burner does not start:

- Press reset button (Fig. 12, **Item 1**).

If the burner does not start after pressing the reset button three (3) times, the cause of the problem must be found with the assistance of the functional diagram (see Chapter 10.1 „Functional diagram“, page 39).

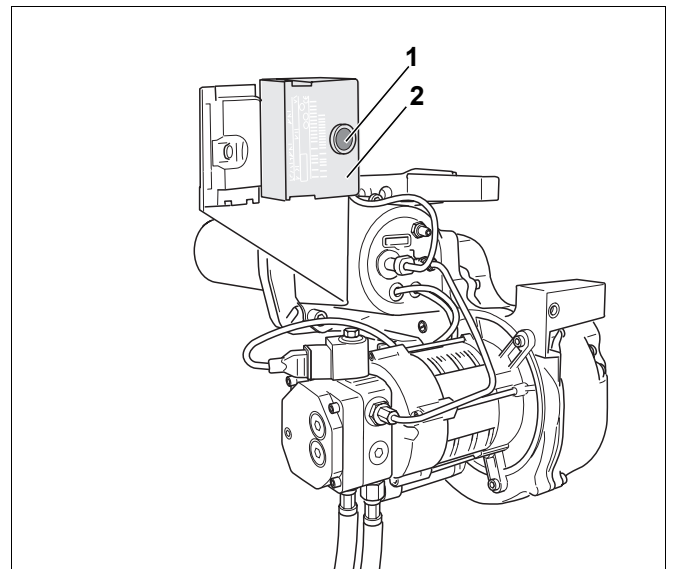

Fig. 12 Reset button and indicator light

Item 1: Reset button

Item 2: Automated burner controller

6.6 Tightening burner door retaining screws

The screws fastening the burner door must be tightened to approx. 8 ft lbs when hot to prevent excess air from entering the combustion chamber.

- Tighten the burner door retaining screws.

6.7 Adjusting the burner

6.7.1 Recording measured values

The measurements are taken in the exhaust pipe (Fig. 13).

The measurement port (coupling; Fig. 13, **Item 2**) should be located distance A (approx. $2 \times$ the diameter of exhaust pipe D) from the boiler rear section (Fig. 13). If the exhaust system is connected to an elbow immediately after the boiler, the measurement must be made before the elbow.

- Make sure that the exhaust pipe is properly sealed between the exhaust connection and measuring point, because additional air will falsify the measurement.

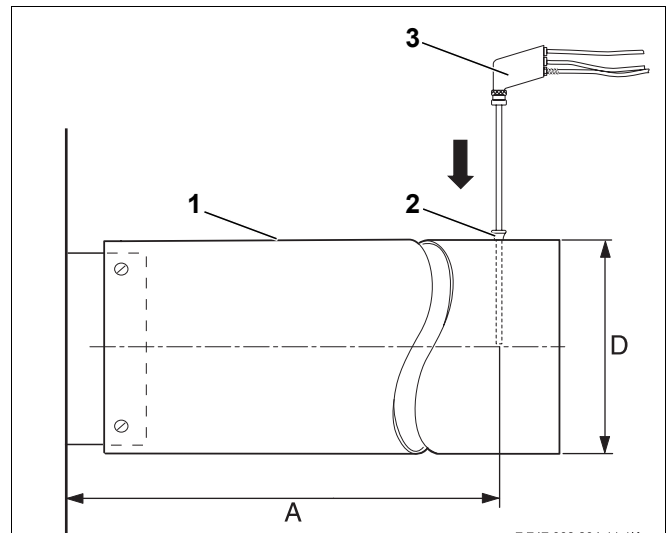

Fig. 13 Recording measured values

Item 1: Exhaust pipe sealing collar

Item 2: Measurement aperture (coupling)

Item 3: Probe

6.7.2 Measuring CO₂-value

The burner has been factory-fired, and set up at the factory for room air independent operation. Combustion air brought in directly from outside can result in large temperature extremes. This requires adjusting the CO₂ on the day of initial startup.

Measure CO₂ with the boiler at approx. 140°F after the burner ran for at least 10 minutes or after the boiler has reached steady state condition.

- Insert temperature probe in the combustion air hose near the back of the boiler and measure combustion air temperature while the burner is running.
- Insert combustion analyzer probe (Fig. 13, **Item 4**) in flue gas pipe and position near center (highest temperature).
- Compare measurements with Fig. 15.

Example:

Combustion air: 77 °F,
with combustion air piped in from outside.
Set CO₂-value to 14.1% ±0.2 %.

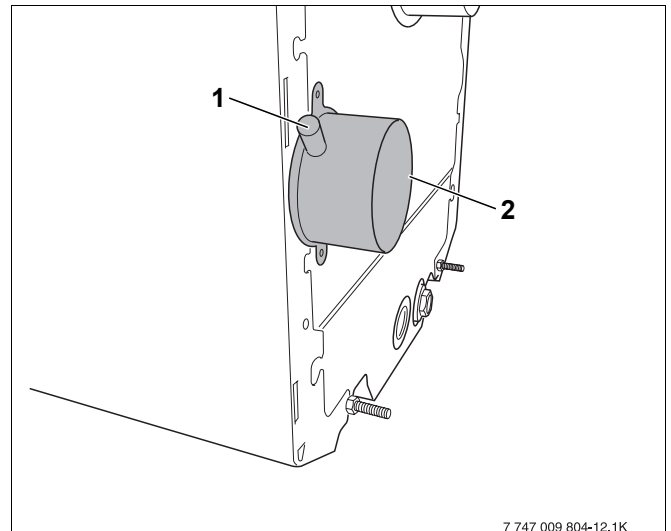

Fig. 14 Combustion air hose

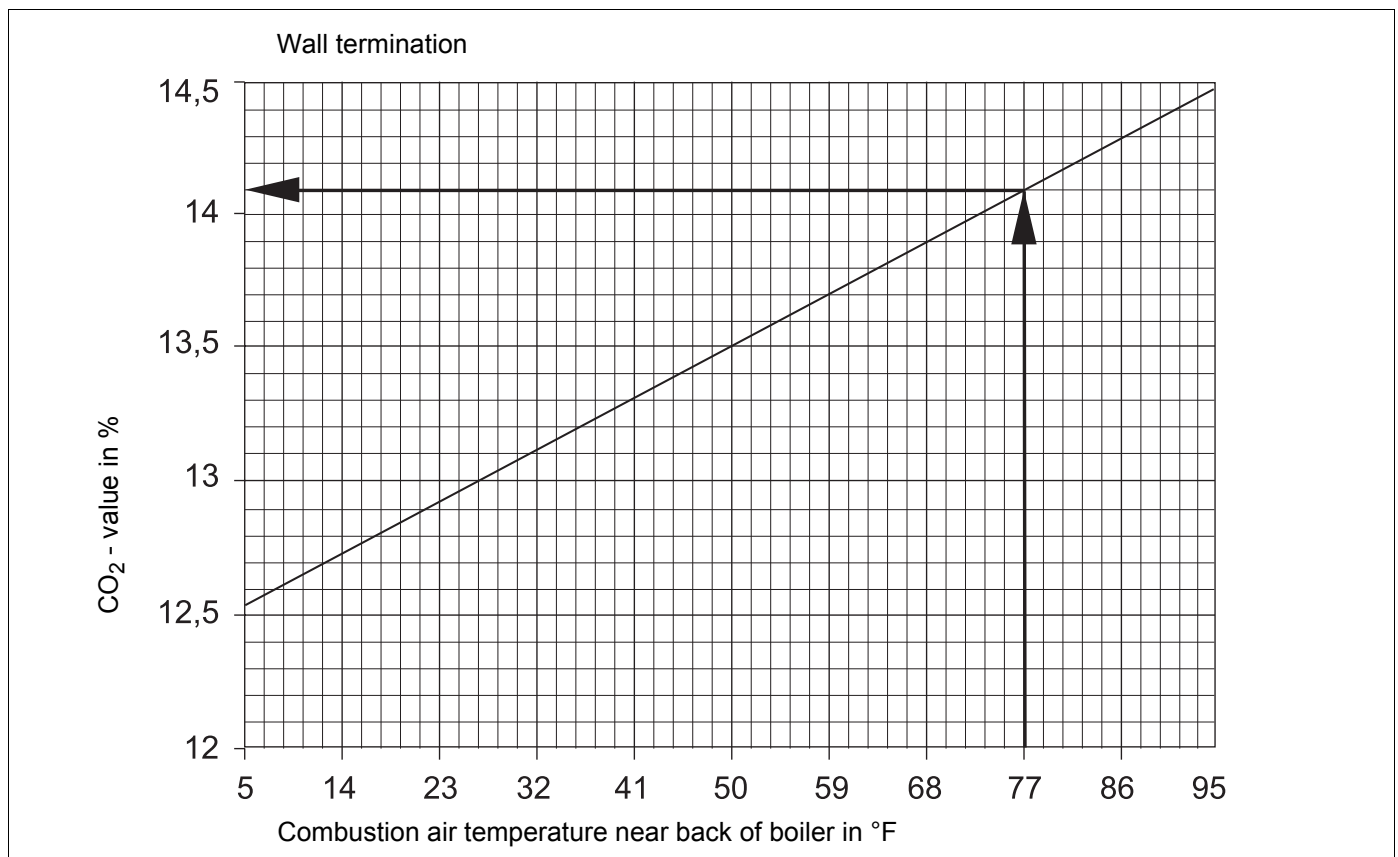

Fig. 15 CO₂-adjustment based on combustion air from outdoors with separate pipes for combustion air and exhaust (valid with or without burner hood installed)

6.7.3 Fine tuning the CO₂-Value

Adjusting the oil pump pressure

By turning the adjustment screw (Fig. 16, **Item 1**) slightly, you can fine tune the oil pressure and consequentially the CO₂-Value.

- Screw the oil pressure gauge to the oil pump (connection "P").

Raise pressure

Rotate clockwise  = Raise CO₂

Reduce pressure

Rotate counter-clockwise  = Lower CO₂

If the specified CO₂ content is not reached within the limits of the oil pressure, the gasket on the combustion side must be checked (see Chapter 8.2 „Verifying tightness of fireside heating surfaces“, page 35).

Adjusting combustion air supply

If you are unable to dial in the CO₂-value by adjusting the oil pressure, because the oil pressure would end up outside of range (Tab. 9), you will need to adjust the amount of combustion air manually.

- Loosen the screw on the blower housing (Fig. 17, **Item 1**).
- Slightly adjust the static plenum pressure by moving the air lever along the scale.
- Adjust the oil pressure as needed (see „Adjusting the oil pump pressure“, page 20), until the CO₂-value reaches the target. If this is not possible, it may be necessary to replace the oil nozzle.



NOTICE

Lower numbers on the scale equal a higher air pressure as shown by the arrow in Fig. 17.

Scale	Air volume	CO ₂ -content
0	maximum	minimum
6	minimum	maximum

Tab. 9 Adjusting the air volume

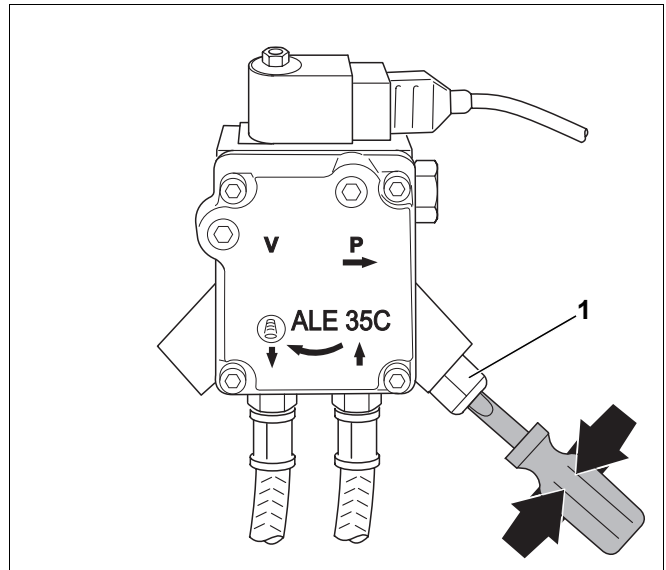

Fig. 16 Adjusting oil pressure - Suntec pump

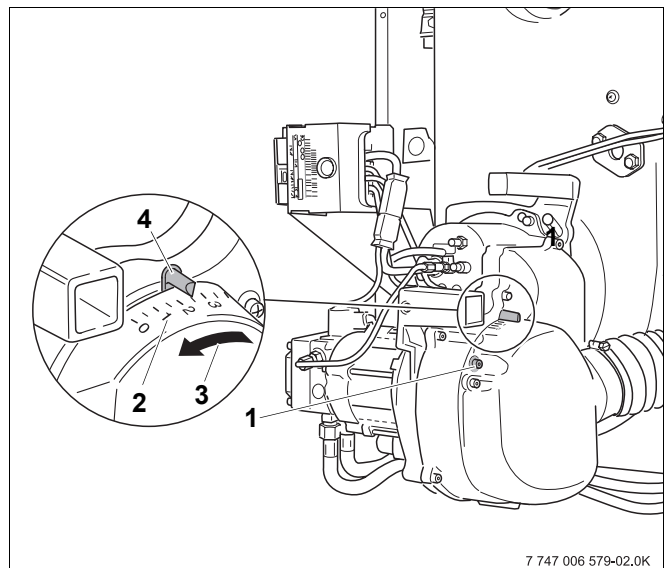

Fig. 17 Adjusting air volume

Item 1: Screw

Item 2: Scale

Item 3: Arrow

Item 4: Adjustment lever

6.7.4 Measuring CO content (carbon monoxide)

The CO content (carbon monoxide content) must be less than 50 ppm (CO < 50 ppm).

- In case of deviations from the specified value: Detect and correct fault (see Chapter 10 „Troubleshooting burner failures“, page 39).



NOTICE

If an excessive CO value is measured on initial start-up, gas generated from organic matter (e.g. burner door insulation) may be the reason.

- Therefore, run the burner for at least 20 - 30 minutes before measuring the CO content.

6.7.5 Measuring chimney draft

If the chimney draft is excessive, a barometric damper must be installed.



SYSTEM DAMAGE

from clogged vent pipe.

CAUTION!

The installation must be performed by a qualified installer in accordance with regulations put forth in NFPA-31 Installation of Oil-Burning Equipment. The installation must comply with all local and national codes, regulations and authorities having jurisdiction regarding the installation of oil fired boilers.

6.7.6 Run particle test

The particle count must be 0 (SMOKE = 0).

- In case of deviations from the specified value: correct fault (see Chapter 10 „Troubleshooting burner failures“, page 39).

6.8 Carrying out safety test

- Pull flame sensor out of the retainer by the handle with the burner operating (Fig. 18, **Item 3**).
- Hold flame sensor against a light source (Fig. 18, **Item 1**). It must shut off immediately, then lock out after restarting.
- Insert flame sensor again after the shutoff.
- After waiting for about 30 seconds, reset the automatic burner controller by pressing the reset button (Fig. 18, **Item 2**).
- Run through function sequence (see Chapter 6.5 „Starting the Burner“, page 17).

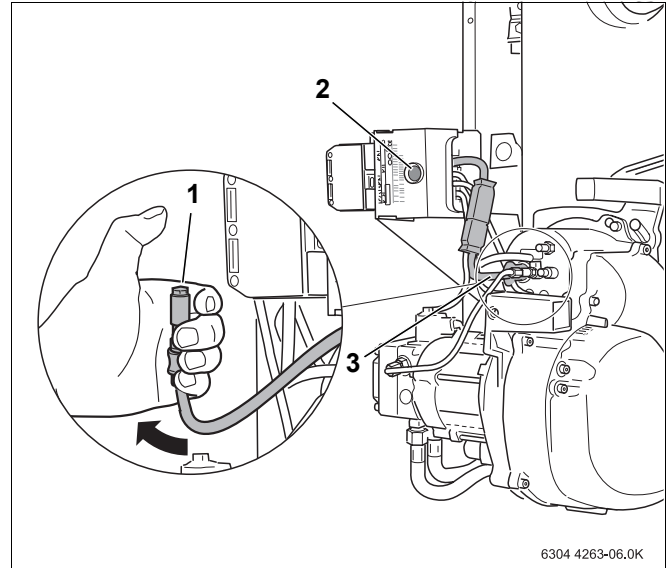

Fig. 18 Check function of flame sensor

Item 1: Flame sensor

Item 2: Reset button

Item 3: Handle on flame sensor

6.9 Installation protocol

- Use this template to document the correct installation of the burner and system.
- Remember to close all measurement ports after probes have been replaced.

Step		Coments or measurements
1. Checking electrical plug connections	page 15	<input type="checkbox"/>
2. Checking and connecting oil lines	page 15	<input type="checkbox"/>
3. Bleeding oil line	page 16	<input type="checkbox"/>
4. Initial burner start-up	page 15	<input type="checkbox"/>
5. Tightening burner door retaining screws	page 18	<input type="checkbox"/>
6. Adjusting the burner	page 18	<input type="checkbox"/>
d) Measuring CO ₂ -value	page 19	_____ %
e) Measuring CO content (carbon monoxide)	page 21	_____ ppm
f) Measuring chimney draft	page 21	_____ W. C. [inch H ₂ O
7. Run smoke test	page 21	
8. Carrying out safety test	page 22	<input type="checkbox"/>
9. Inform homeowner, hand over manuals		<input type="checkbox"/>
10. Confirm that the installation has been performed properly		<input type="checkbox"/>
Company representative/Installer/Signature/Date		

7 Burner start-up and maintenance

This chapter describes how to start-up and maintain the burner.

- Complete the “Inspection and Maintenance Protocol” (see Chapter 7.11 „Inspections and maintenance protocol“, page 32).

Prior to inspection/maintenance work, it is essential to record measured performance values during burner operation. Disconnect and shut off the heating system before performing any inspection and warranty maintenance work.



NOTICE

Spare parts can be obtained through your Buderus wholesaler.

7.1 Record and correct burner measurement values

Obtain burner test values as described in Point 1 of the maintenance protocol.

The boiler water temperature has a significant effect on the flue gas temperature. Perform burner performance testing near a boiler water temperature of 140 °F and operate the burner for a minimum of 5 minutes.

- Insert the flue gas analyzer probe (Fig. 19, **Item. 4**) into the main flue gas flow at the vent connection (Drill hole in flue pipe if necessary).
- Record CO₂, CO and flue gas temperatures in start-up protocol report (see Chapter 6.9 „Installation protocol“, page 23).
- If deviations are detected, re-adjust the burner (see Chapter 6.7 „Adjusting the burner“, page 18).
- Seal test port completely following testing.

7.2 Inspecting burner hood and burner

- Inspect the inside of the burner cover and burner outside surfaces for any debris or soot build-up.
- Look for dust, corrosion, leaking oil lines, or damaged electrical cables, defective sheet metal housing or jacket damage.
- Identify the source of defects.
- Repair as necessary.

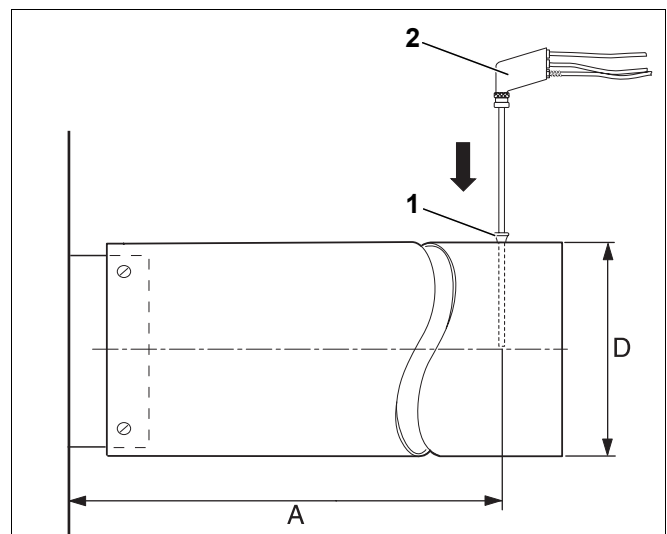

Fig 19 Record burner test values

Item. 1: Test opening

Item. 2: Test probe

7.3 Verify burner motor operation

- Test burner motor function and listen for excessive noise.

Excessive operating noise.

- Replace burner motor in such cases.

7.4 Shutting off the burner

- Shut off manual oil valve.
- Shut off the heating system electrically by shutting off the emergency shutoff switch or the heating system circuit breaker.
- Remove burner front cover.
- Remove electrical cable from burner.

7.5 Clean oil pump

- Loosen 4 Allen head screws (Fig. 20, **Item. 1**).
- Remove pump cover (Fig. 20, **Item. 2**).
- Remove filter (Fig. 20, **Item. 3**).
- Visually check the condition of the gasket (Fig. 20, **Item. 4**) for damage. Replace gasket annually.
- Clean filter (Fig. 20, **Item. 3**) with gasoline, replace if excessive residue remains or filter shows signs of damage, then reassemble the oil pump.

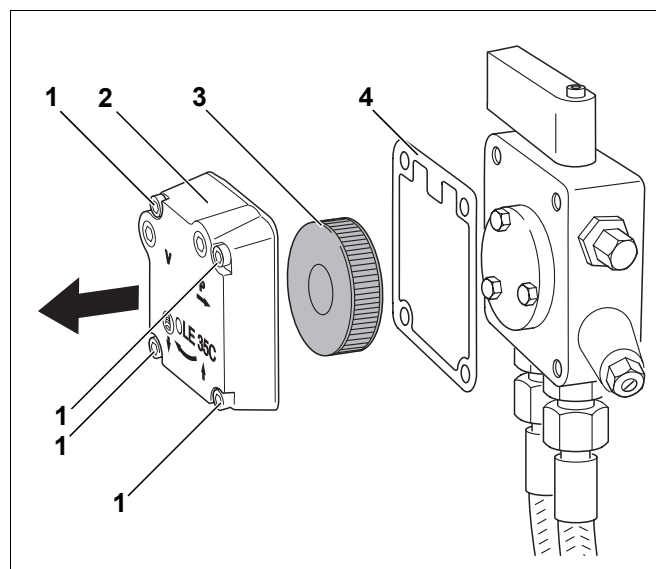

Fig 20 Check oil pump filter – Suntec oil pump

Item. 1: Hex head screws (4)

Item. 2: Pump cover

Item. 3: Oil pump filter

Item. 4: Oil pump gasket

7.6 Check fan housing for contamination and damage

Follow procedure when checking the fan housing assembly:

Disassemble the air intake noise attenuator

- Loosen hose clamp (Fig. 21, **Item. 1**) for the combustion air intake hose.
- Slide hose off the muffler.
- Remove screws (Fig. 21, **Arrows**) and take off muffler (Fig. 21, **Item. 2**).

Remove burner air intake cover

- Loosen and remove the 6 screws that hold the air intake housing (Fig. 22, **Arrows**).

7.6.1 Minor dust or contamination

- Clean air intake housing with a brush.

7.6.2 More significant contamination

- Loosen and remove blower wheel (Fig. 23, **Item. 1**) with an Allen head wrench (Fig. 23, **Item. 2**) from the spindle.
- Clean blower wheel and housing with water and mild detergent.
- Reassemble blower wheel and air intake housing (Fig. 23, **Item. 1**).

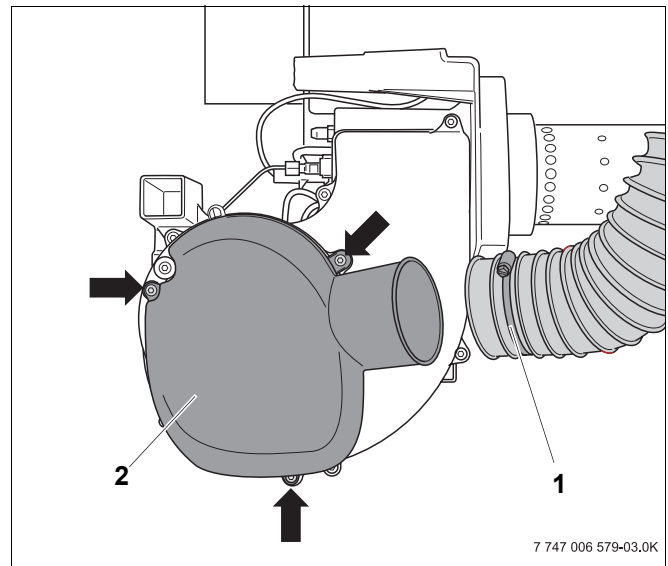

Fig 21 Disassembly of air intake noise attenuator

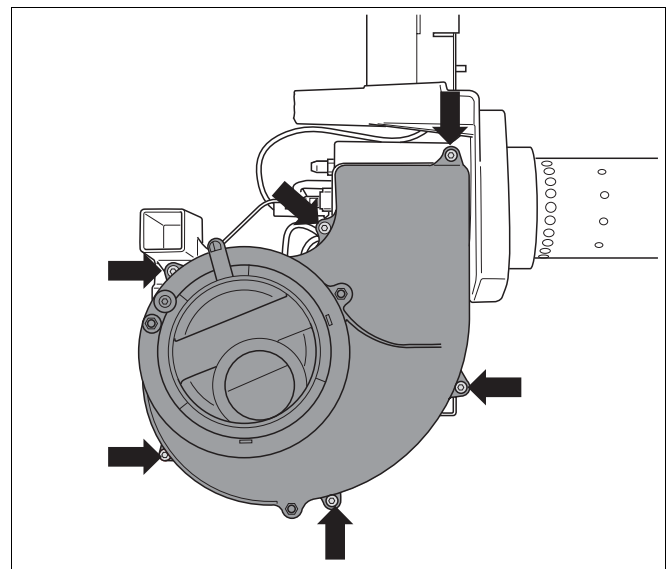

Fig 22 Disassembly of air intake housing

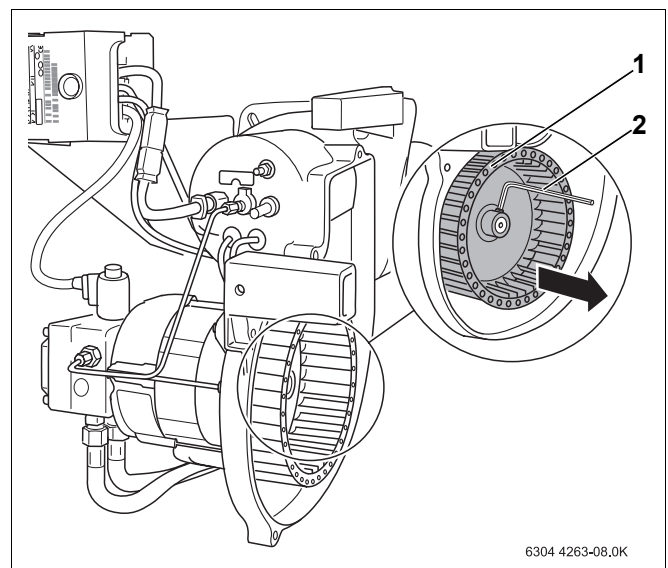

Fig 23 Test and clean the blower wheel



NOTICE

The screw must face the flat spot on the spindle. The distance between back side of blower wheel and motor housing must be about 1/64".

- Re-install the air intake housing (Fig. 22) and air intake muffler (Fig. 21, **Item. 1**).



WARNING!

PERSONAL INJURY

- Operate the burner only with the muffler installed.

7.7 Checking ignition electrodes, mixing system, gasket, nozzle, and burner tube

- Loosen the 2 main burner service bolts (Fig. 24, **Arrows**).



NOTICE

Servicing the burner is simplified when bringing it into the Service Position (Fig.25).

- Remove and hang the burner as shown in Fig 25.

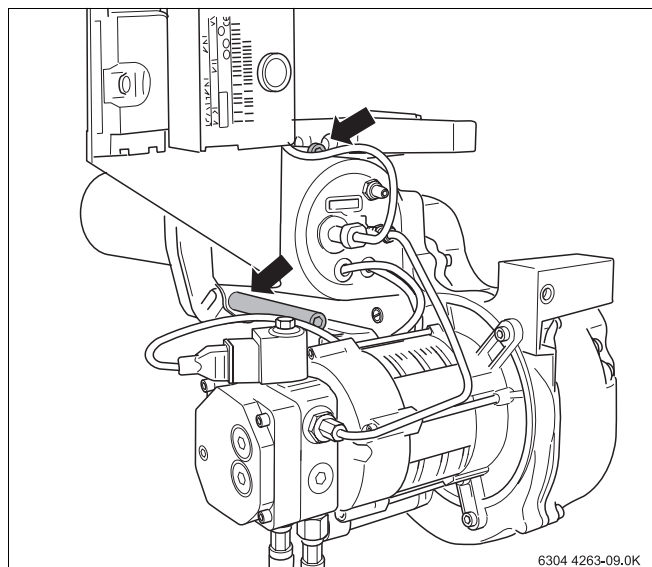

Fig 24 Removal of burner service bolts

7.7.1 Check electrodes and replace as needed

The ignition electrodes (Fig. 25, **Item. 1**) must be free of any build-up.

- Maintain indicated dimensions, clean or replace ignition electrodes if needed (see Chapter 4 „Technical data and scope of delivery“, page 9).

Follow the steps below when replacing the ignition electrodes:

- Loosen and remove screw between the ignition electrodes (Fig. 26, **Item. 1**).
- Remove ignition cables (Fig. 26, **Item. 4**).
- Remove ignition electrodes (Fig. 26, **Item. 5**).

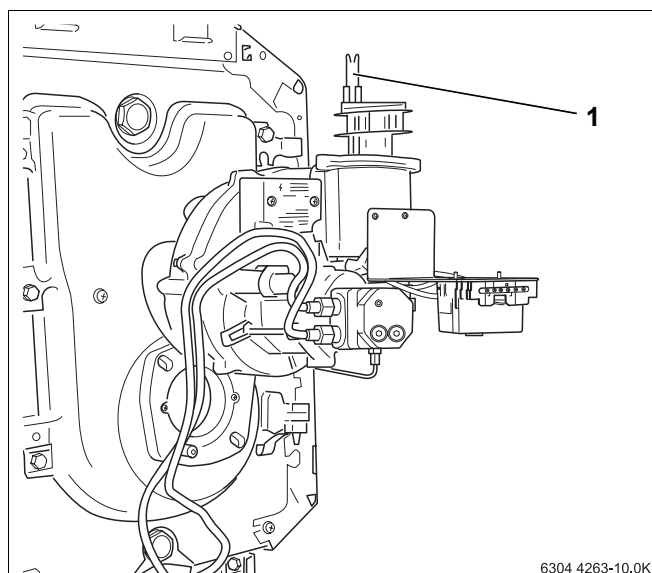

Fig 25 Place burner in service position



SYSTEM DAMAGE

from damaged ignition cables.

WARNING!

- DO NOT USE pliers or other tools to remove or install the ignition cables.

7.7.2 Check the mixing system (replace as needed)

A slight, dark residue build-up on the mixing system/diffuser plate is normal and does not affect burner performance. Clean the mixing system/diffuser plate in case of significant build-up. Observe the technical characteristics of the mixing system/diffuser (see Chapter 4 „Technical data and scope of delivery“, page 9).

- Loosen locking screw (Fig. 26, **Item. 3**) and slide the mixing system/diffuser (Fig. 26, **Item. 2**) upward.

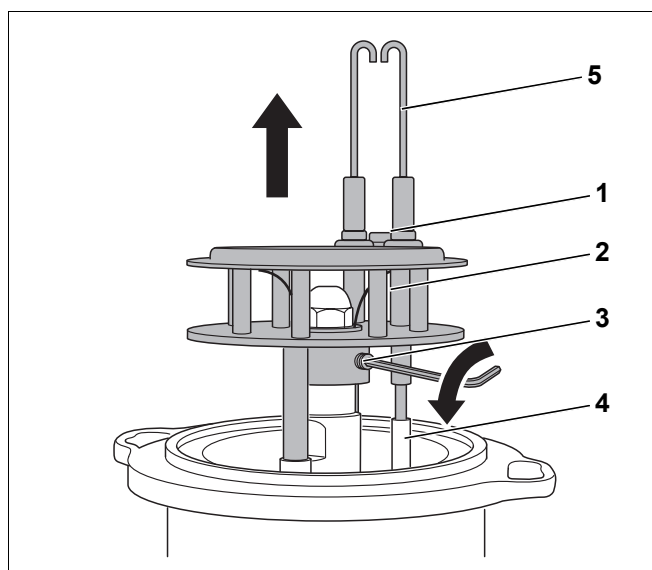

Fig 26 Disassembly of mixing system/diffuser plate

7.7.3 Replacement of oil nozzle

**NOTICE**

The oil nozzle must be replaced as part of the annual service. Use the correct nozzle as specified (see Chapter 4 „Technical data and scope of delivery“, page 9).

- Loosen and remove the oil nozzle (Fig. 27, **Item. 1**) using 2 wrenches, 16 and 19 mm.

**NOTICE**

Replace the shut-off valve in the oil pre-heater, when it is defective (see Chapter 7.7.4 „Checking the shut-off valve in the oil pre-heater“, page 29) and possibly replace.

- Install new oil nozzle.
- Re-assemble mixing system/diffuser plate (Fig. 28, **Item. 3**).
- Correctly connect the ignition cables (Fig. 28, **Item. 4**).
- Slide the positioning rod (Fig. 28, **Item. 2**) back into its proper guide rod (Fig. 28, **Item. 1**).

**NOTICE**

- Secure the mixing system/diffuser plate so that the positioning rod and guiding rod are engaged.

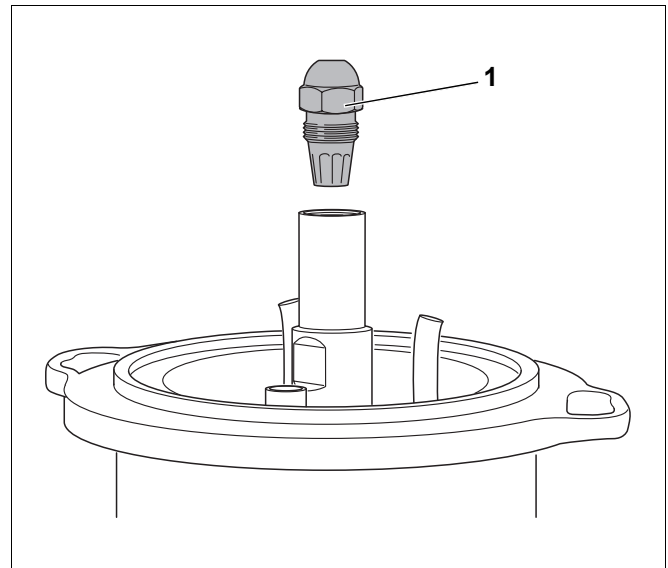

Fig 27 Removal of oil nozzle

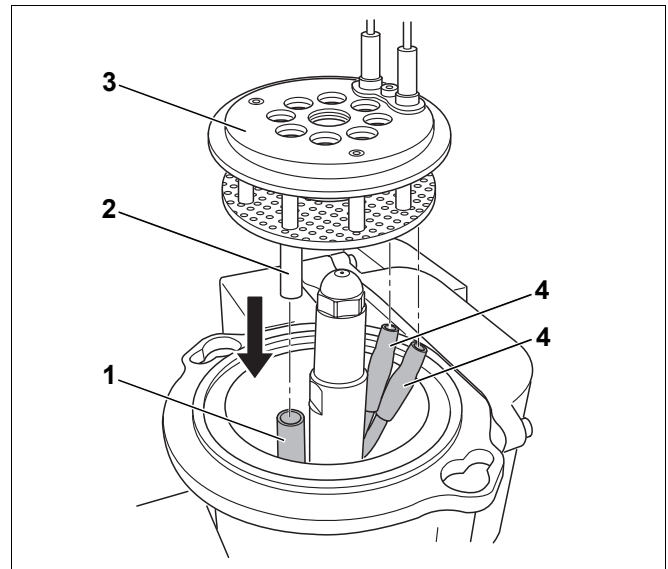

Fig 28 Assembly of mixing system/diffuser plate

Item. 1: Guiding rod

Item. 2: Positioning rod

Item. 3: Mixing system/diffuser plate

Item. 4: Ignition cables

7.7.4 Checking the shut-off valve in the oil pre-heater

The shut-off valve in the oil pre-heater (Fig. 29, **Item. 3**) functions as an after-drip preventer. Oil pushes against the shut-off valve during oil pump operation. As soon as the oil pump shuts off, an internal spring closes the shut-off valve (Fig. 29, **Item. 1**).

- When oil is observed on the outside of the burner, this indicates a defective shut-off valve. Replace the shut-off valve.
- Remove the oil nozzle(Fig. 27, page 28).
- Screw a M5x50 screw (Fig. 29, **Item. 2**) in and remove the shut-off valve (Fig. 29, **Item. 3**).
- Remove the screw and screw it into a new shut-off valve.
- Install the new shut-off valve with the M5x50 bolt and remove the bolt.
- Install the oil nozzle.

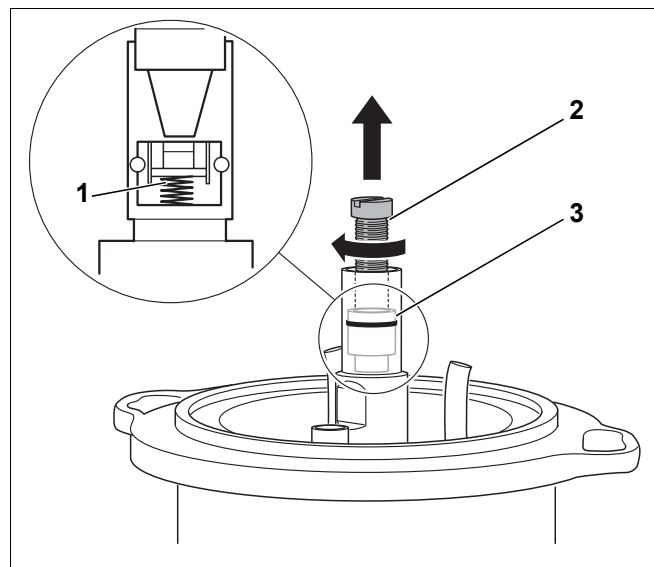

Fig 29 Removal of shut-off valve of oil pre-heater

Item. 1: Spring of shut-off valve

Item. 2: M5x50 screw (in mm)

Item. 3: Shut-off valve

7.7.5 Inspecting the burner tube

- Open the boiler door.
- Visually inspect the burner tube. Carefully clean the burner tube and replace damaged.

Replacement of burner tube

- Pull the burner tube from support collar.



NOTICE

Handle the ceramic burner tube carefully, as it easily shatters.

- Note the part number of the existing burner tube and replace with the proper model. Refer also to technical data (see Chapter 4.2 „Burner tubes“, page 10).
- Place the new burner tube into the locking collar (Fig. 30, **Item. 5**). Slide the burner tube past the lip (Fig. 30, **Item. 2**) and engage the tube with the locking collar. The lip of the burner tube must point downward and must be engaged (Fig. 30, detail).
- Use a new burner tube gasket (Fig. 30, **Item. 6**).

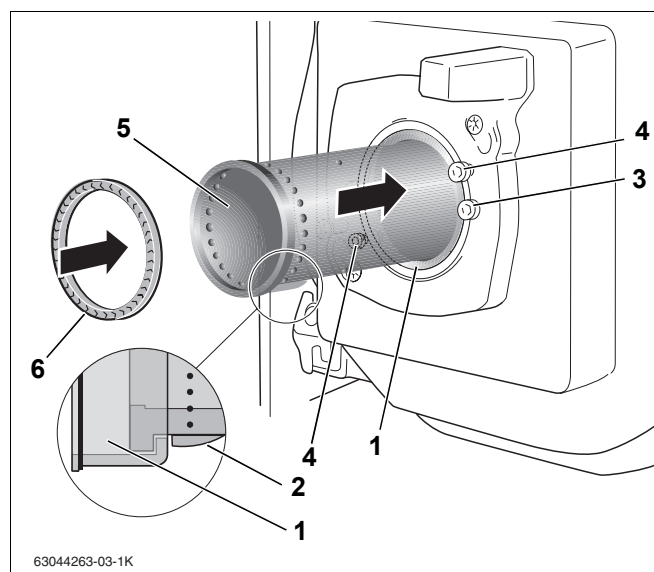

Fig 30 Replacing the burner tube

Item. 1: Locking collar

Item. 2: Lip

Item. 3: Mounting screws for locking collar

Item. 4: Burner service bolt screws

Item. 5: Burner tube

Item. 6: Gasket

7.7.6 Burner installation and checking of burner gasket

- Always replace the gasket (Fig. 30, page 29) between the mixing system/diffuser plate and burner tube prior to burner re-installation.



NOTICE

New gaskets ensure trouble free operation and proper flue gas values.

- Place gasket in burner tube (Fig. 30, page 29).
- Return burner in its position in the door on both bolts (Fig. 30, page 29).
- Slide mixing system/diffuser plate into the burner tube.
- Turn counter-clockwise until stop and tighten with mounting screws (Fig. 30, page 29).

Verify proper position of the mixing system/diffuser plate, after the burner is installed.

- Pull out the oil line about 1/4" (Fig. 31, **Item. 1**).



NOTICE

The mixing system/diffuser plate must automatically engage and return to its proper position. If this does not happen, it can pull in excessive air, which will cause improper operation.

- Verify proper placement of the gasket (Fig. 32, **Item. 1**), with the burner door open (Fig. 32, **Item. 2**).

7.8 Securing boiler door bolts

- Close boiler door (Fig. 32, **Item. 1**) and secure with two bolts. Torque to 35 ft-lbs.



NOTICE

Retighten the boiler door bolts after the boiler has warmed up.

7.9 Check electrical connections

- Reconnect electrical connections.
- Check all electrical connections for proper fit and placement.

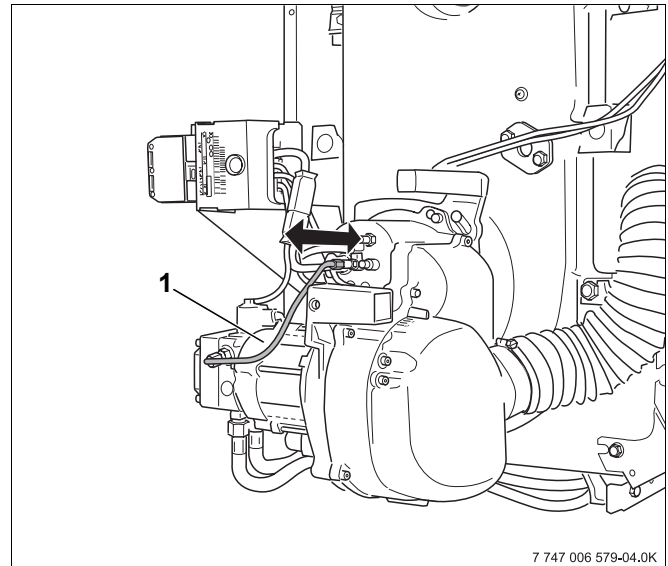

Fig 31 Check proper position of mixing system/diffuser plate

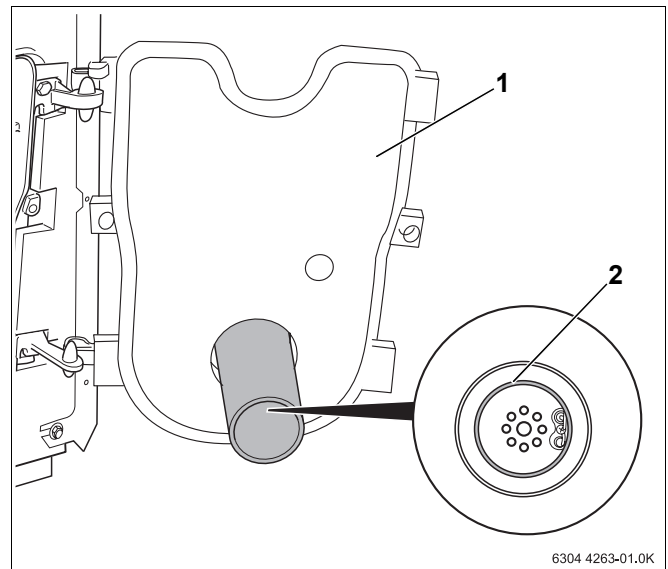

Fig 32 Check gasket for proper positioning

7.10 Conducting the safety test

- Start-up the burner (see Chapter 6.5 „Starting the Burner“, page 17).
- With burner in operation, remove flame sensor by pulling on the handle at its end (Fig. 33, **Item. 3**).
- Expose flame sensor to light (Fig. 33, **Item. 1**). The burner must go into lock-out mode.
- Clean flame sensor with a clean rag.
- Install the flame sensor after burner shut-off.
- Wait for 30 seconds until the primary burner controller went into lockout. Then press the burner reset button, and restart the burner (Fig. 33, **Item. 2**).
- Check and verify that the flame is visible for the flame sensor. Clean the burner if necessary. (To test flame sensor, see Chapter 8.1 „Measurement of the flame sensor current“, page 34).
- For testing procedure of the flame sensor, refer to page 34.

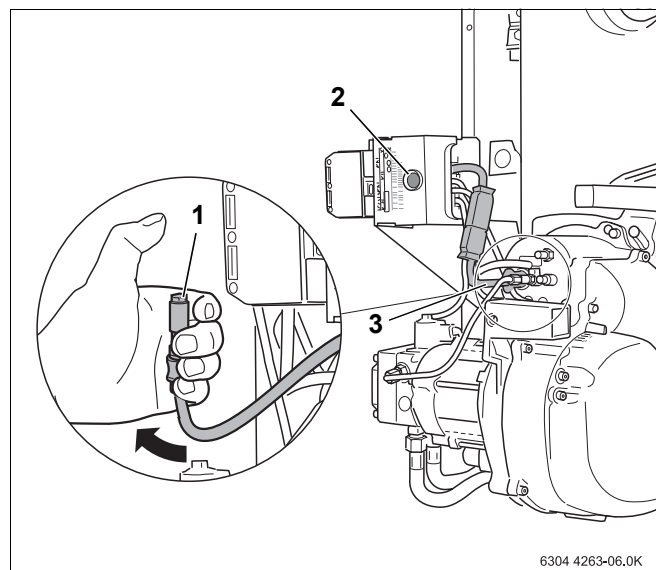

Fig 33 Checking the flame sensor

Item. 1: Flame sensor

Item. 2: Reset button

Item. 3: Handle on flame sensor

8 Additional service tests

This chapter describes how to measure the flame sensor current and how to perform the flue side air tightness test.

8.1 Measurement of the flame sensor current

The sensor current can be verified with a multi-meter (Fig. 34, **Item 1**) with MicroAmp measuring capability. An unstable flame signal (sensor current < 45 microAmp) is also shown on the LED of the LMO (blinking green light) (see Table 7, page 13). The sensor current during operation must be at least 80 microAmp (no flame < 5 microAmp).

When the sensor current is less than 80 microAmp, the flame sensor must be cleaned and the opening to the combustion chamber must be checked for contamination.

- Remove flame sensor during burner operation from its position by pulling on the handle.
- Clean flame sensor with a soft cloth.
- Re-install flame sensor.

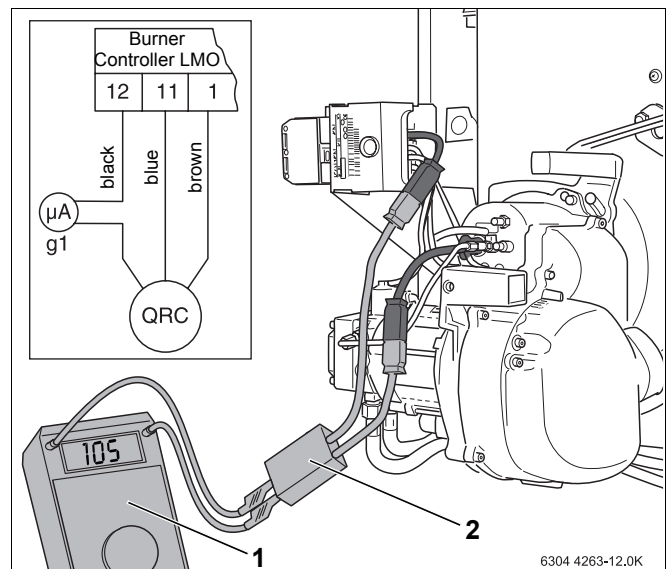

Fig. 34 Schaltbild und Fühlerstrommessung durchführen

8.2 Verifying tightness of fireside heating surfaces

Errors in the CO₂ reading can occur based on flue gas leaks between the boiler block sections or leaks in the flue gas system. A reduced CO₂ value in the venting system compared to the CO₂ value in the combustion chamber can result from air introduced through cracks and vent pipe joints. Verify the validity of the CO₂ measurement by performing the following test:

8.2.1 Establishing the upper limit

The burner is typically operated with a certain amount of excess air.

When reaching the stoichiometric limit of the fuel/air mixture, a rapid increase in CO value will result.

The CO₂ value will also approach 14.8% when approaching the stoichiometric limit.

Proceed in the following manner:

- Increase the oil pressure, until CO reaches 100 to 200 ppm.
- Record the corresponding CO₂ value.

If the measured CO₂ value is below 14.3% (Deviation of more than 0.5% in CO₂), there is likely an air leak between the burner combustion and the test location.

- Find and close off the air leak path. Repeat the above test to confirm that 14.8% CO₂ can be reached as above.

8.2.2 Performing tests in the combustion chamber

Flue gas measurements are typically conducted in the flue gas pipe (see Chapter 7.1 „Record and correct burner measurement values“, page 24).

A direct combustion measurement in the combustion chamber can be performed through the sight glass in the boiler door.

When the deviation in combustion measurements between combustion chamber and venting system test port is greater than 0.5%, a leak on the flue gas side is likely and must be found and removed for safety reasons.

- Identify and close off flue gas leak.

After sealing of the flue gas leak, the combustion performance of the burner should be optimized (see Chapter 6 „Initial burner start-up“, page 15).

9 Layout of oil supply system



NOTICE

Do not add oil additives to the oil, as they will not improve the combustion characteristics.

9.1 Installation of the oil filter

- Installation of an oil filter in the Tigerloop near the burner is required.



SYSTEM DAMAGE

from plugged nozzles.

CAUTION!

- Routinely inspect the Tigerloop, vacuum gauge and filter for proper operation. Replace filter annually, or when vacuum gauge indicates increased restriction outside of the green area.



NOTICE

Suitable oil filters can be obtained through you local Buderus wholesaler.

Parameters for the Oil Delivery System	Value
Inner Diameter of Oil Supply Lines	3/8"
Maximum Rise	12 feet
Maximum Supply Pressure	7.3 psi
Maximum Return Pressure	14.5 psi
Maximum Suction Pressure Drop (Vacuum)	5.8 psi

Table 10 Technical data for oil supply system

Nozzle Size (gph)	Filter Size (Microns)
0.40 – 0.60	10 or less
> 0.6	10 or less

Table 11 Recommended filter types

9.2 Sizing the oil supply lines

The burner is installed in single pipe systems. The suction and return lines of the burner must be connected to the furnished "Tigerloop" de-aerator and oil filter. A single fuel supply line then runs from the "Tigerloop" filter to the oil tank. (see Fig. 35).



NOTICE

Installation of the Tigerloop Ultra with oil filter and automatic air elimination is required for the G125 BE burner.

Consider all horizontal and vertical pipe lengths as well as all elbows and valves when calculating the total equivalent length of the oil supply system.

Table 12 shows the maximum lengths of supply line(s) in feet which are dependent on suction height and smallest pipe diameter. The individual resistance of shut-off valves, check valves and 4 elbows has been included in the table.

The maximum allowed supply length must be reduced accordingly in case of additional valves or fittings in the supply line.

Be extremely careful when repositioning the oil line.

The oil supply line must be terminated sufficiently close to the burner that the furnished flexible oil lines can be connected without undue strain.

Use approved materials for the oil line. Use only metallic flared connections when using copper supply lines.

Maximum supply lengths (L) with inner diameter 3/8" for suction lines

1-Pipe System	L
Oil tank above burner	to 330 feet
Oil tank below burner H to 10 feet	to 110 feet

Table 12 Maximum lengths for oil pipe

9.3 Testing for oil line vacuum

The maximum vacuum (negative gauge pressure) of 5.8 psi (13.4 ft of head), measured at the suction connection of the oil pump, can never be exceeded, regardless of the fill level of the tank.



NOTICE

The vacuum in the oil line should be measured with a 3.3 ft. long transparent hose to test and verify the integrity of the oil supply line.

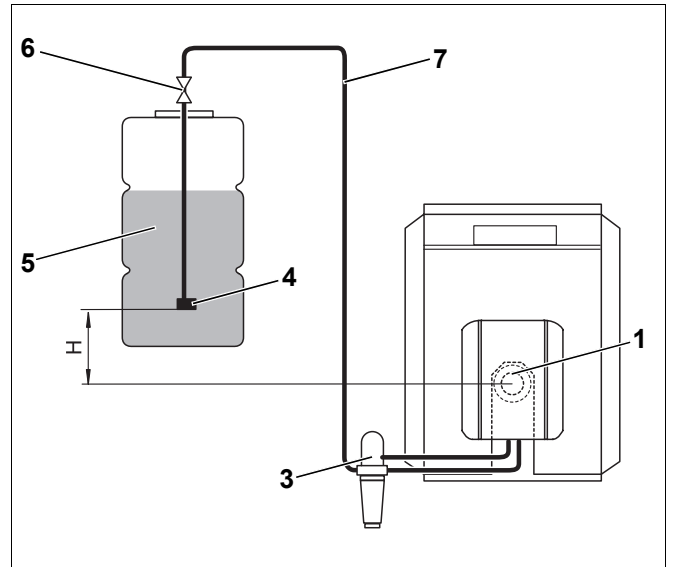

Fig. 35 1-pipe system (oil tank above oil pump)

Item 1: Burner

Item 2: Check valve

Item 3: Oil filter with built-in shut-off valve

Item 4: Suction cup

Item 5: Oil tank

Item 6: Tank valve with quick disconnect

The maximum vacuum is dependent on the lay-out of the oil delivery system and the fill level of the oil tank.

In case of exceeding the maximum allowed vacuum, check the following possible reasons:

- Oil connection line is kinked or defective.
- Oil filter is solidly plugged.
- Shut-off valve is not fully opened, or plugged.
- One or several system components (such as shut-offs, flared connections, oil lines, oil filter connections, oil tank) are due to installation error (over torqueing) pressed together.
- Connection at oil tank is plugged.
- Suction hose in tank is collapsed due to aging.
- Suction valve in tank is collapsed due to high suction pressure or plugged.

9.4 Testing Integrity of oil supply line

Use a transparent hose (dia: 1/2", accessory) to verify that there are no air leaks in the burner supply loop.

- Connect hose (Fig. 36, **Item 1**) in suction line between the TigerLoop (Fig. 36, **Item 2**) and the oil line.
- Form a loop as shown (Fig. 36).
- Start burner and run for at least 3 minutes.
- Shut burner OFF.
- Verify if air bubbles are collecting at the highest point of the hose (Fig. 36, detail **A** and **B**).

Small amounts of air are permitted (Fig. 36, **A**). Larger air bubbles indicate a leak (Fig. 36, **B**) which needs to be found and corrected.

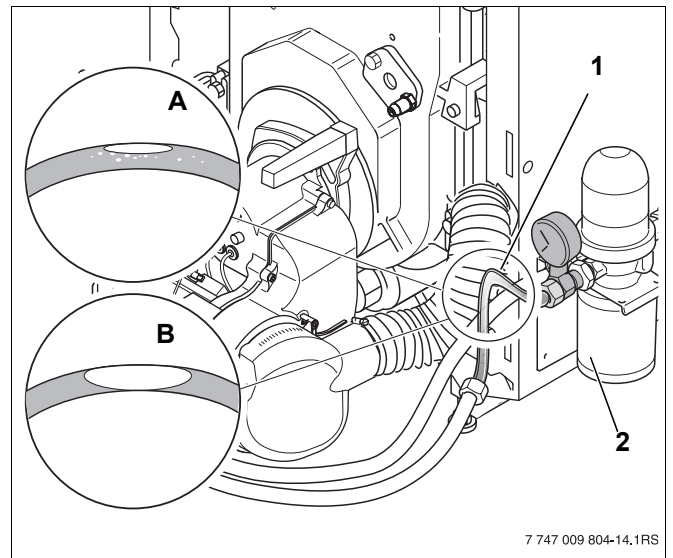

Fig. 36 Testing the air tightness of the oil supply line

Item 1: Transparent hose

Item 2: Tigerloop oil filter

9.5 Use of vacuum valve

In installations where an automated oil shut-off valve is required, only electrically controlled solenoid shut-off valves are permitted. Contact Buderus for wiring schematic.

10 Troubleshooting burner failures

10.1 Functional diagram

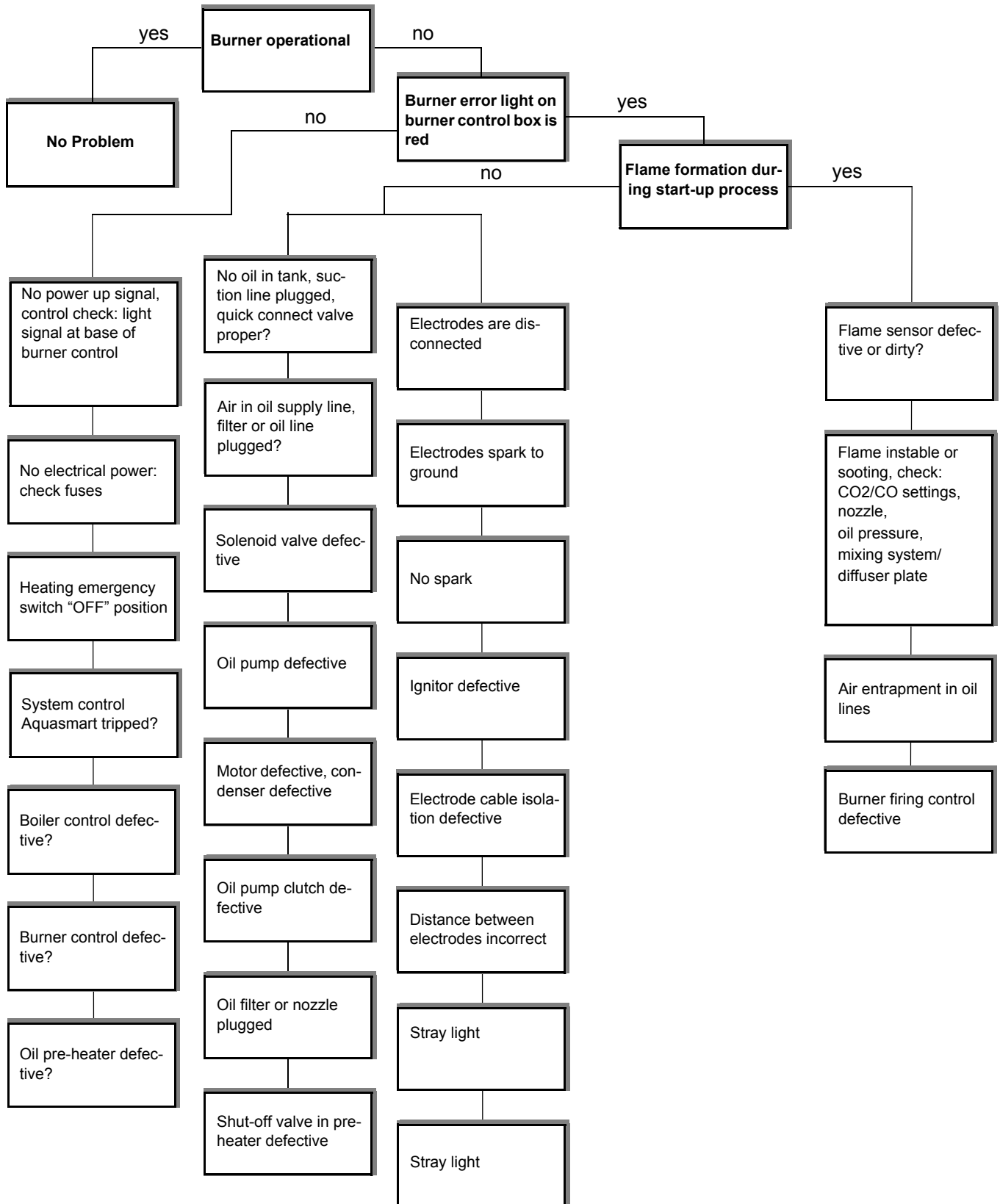

10.2 Burner failure - reasons and solutions

Burner Failure	Reason	Solution
CO ₂ -Value too high	Air fan pressure too low	Increase fan pressure (see Chapter 4 „Technical data and scope of delivery“, page 9).
	Oil flow too high	Reduce oil pressure (see Chapter 4 „Technical data and scope of delivery“, page 9). Check mixing system.
	Insufficient combustion air	Check fresh air supply. Provide more combustion air.
	Burner dirty	Clean burner and fan housing.
	Incorrect nozzle selection	Change oil nozzle.
	Damaged nozzle	Change oil nozzle.
	Incorrect air mixture	Change out mixing system/diffuser plate.
CO ₂ -Value to low	Fan pressure too high	Reduce fan pressure (see Chapter 4 „Technical data and scope of delivery“, page 9).
	Oil flow too low	Increase oil pressure (see Chapter 4 „Technical data and scope of delivery“, page 9).
	Entry of excess air	Check tightness of boiler door bolts. Check air tightness of vent pipe (see Chapter 8.2 „Verifying tightness of fireside heating surfaces“, page 35).
	Gasket defective between burner tube and mixing system	Install new gasket.
	Incorrect mixing system	Check mixing system.
	Incorrect oil nozzle	Change out oil nozzle.
	Defective oil nozzle	Change out oil nozzle.
	Plugged nozzle filter	Change out oil nozzle.
Burner does not run	Power outage	Check main breaker, emergency shut-off switch, boiler Aquasmart control and STB controller.
	Open circuits in control panel?	Check boiler control panel.
	Defective oil pre-heater thermostat?	Replace oil pre-heater.
	Caution: After longer shut-off times, the burner start-up time can be 2 to 3 minutes	In case of excessively long start-up delays: check burner primary controller, check burner motor. Replace if necessary.
Burner starts, oil level at sight glass of oil filter remains empty	Incorrect connections at initial burner start-up	Check proper connection of oil lines.
	Oil line does not fill after initial start-up; several minutes pass before oil is available	Vent oil lines (see Chapter 6.3 „Checking and connecting oil lines“, page 15).
	Oil in tank? Open connection in oil supply line?	Check oil level and verify shut-off in oil line.
	Incorrect flow direction for flow check?	Verify proper flow check operation.
	Defective coupling between motor and pump	Replace coupling.
	Defective suction line or excessive vacuum levels. Oil line pressed together.	Check oil supply line (see Chapter 9.4 „Testing Integrity of oil supply line“, page 38).
	Separate shut-off closed. External shut-off closed.	Open defective shut-off. Check entire oil supply lines.
Burner starts up, oil pressure available, no ignition, emergency shut-off.	Ignition transformer or ignition cable defective.	Replace ignition transformer or ignition cable. Check power to ignition transformer.
	Used electrodes or damaged insulating material.	Replace ignition electrodes.
	Incorrect setting of electrodes.	Correct electrode settings.
	False flame sensing.	Check flame sensor, replace as needed. Check solenoid and oil pump. Replace as needed.
	Burner Primary control defective.	Replace burner primary control.

Table 13 Troubleshooting Table

Burner Failure	Reason	Solution
Burner starts up and ignition took place, yet no flame sensing.	Flame sensor dirty or defective	Clean or replace flame sensor.
	Burner Primary control defective	Replace burner primary control.
Burner runs, ignition is operating, yet flame does not ignite and burner shuts off.	Oil solenoid valve does not open	Replace oil solenoid valve. Check electrical connections.
	Improper flow through oil line, pre-heater or nozzle.	Check oil line, oil pre-heater or nozzle; replace as needed.
	Oil pump does not draw oil, tank empty	Check pump and tank indicator; replace if needed. Fill tank.
	Oil nozzle filter plugged	Replace oil nozzle.
	Air leaks in suction line	Check suction line. Tighten connections.
	Air not completely bled from suction line	Vent suction line at manometer location of oil pump.
	Plugged oil filter	Clean or replace oil filter.
	Mixing system dirty	Check and clean mixing system.
	Burner adjustment out of order	Check and correct burner settings.
	Shut-off valve in oil pre-heater defective	Replace shut-off valve (see Chapter 7.7.4 „Checking the shut-off valve in the oil pre-heater“, page 29).
Flame failure light is red.	Display of a failure in the burner primary control	Read blinking code (see Chapter 5.3 „Repairing faults in the automated burner controller LMO“, page 14).
Delayed or “hard” starts.	Incorrect arrangement of ignition electrodes	Check electrodes, replace if necessary. Caution: Due to repeated start attempts oil fumes can accumulate which can cause hard starts.
	Oil pressure too low	Correct oil pressure.
	Defective oil nozzle	Replace oil nozzle.
	Loose connections between oil pump, oil line, oil pre-heater and oil nozzle	Check all connections for leaks.
	Dripping nozzle, uncontrolled oil vapors	Solenoid does not close. Replace solenoid, possibly oil pump. Shut-off in oil pre-heater defective. Replace.
	Air in nozzle discharge	Check entire oil delivery system for air leaks.
	Draft regulator (chimney vent only) locks open, affecting draft conditions	Check operation of barometric draft regulator.
	Solenoid does not open properly	Check coil, replace if necessary.
Plugged nozzle, soot deposits on mixing system/diffuser plate	Defective nozzle	Replace nozzle.
	Excessive oil pressure	Correct oil pressure.
	Incorrect oil nozzle	Check nozzle selection (see Chapter 4.3 „Settings and nozzle specification“, page 10). Replace nozzle.
	Incorrect mixing system	Check mixing system, or replace (see Chapter 4.1 „Burner-types“, page 9).
	Dirty mixing system	Clean mixing system.
	Incorrect ignition electrodes	Check electrodes, replace as needed (see Chapter 4.1 „Burnertypes“, page 9).
	Leakages between nozzle and pre-heater	Clean nozzle and pre-heater carefully, possibly replace. Check gaskets.
	Fluctuating oil pressure and air influence	Vent oil line system.
	Incorrect combustion chamber pressure.	Check draft conditions; possibly install barometric damper.
	Defective gasket between mixing system and burner tube	Check gasket, replace as needed.
Post burner shut-off discharge, post oil burning after burner shut-off.	Defective pressure regulator	Replace oil pump.
	Insufficient air bleeding of oil lines	Bleed air from oil lines completely (see Chapter 6.4 „Bleeding oil line“, page 16).
	Oil suction hose defective, or air in oil lines	Check all connections of oil delivery system.

Table 13 Troubleshooting Table

11 Spare part listing

The following spare parts are available via your Buderus wholesaler or BBT North America Corp. In case one position refers to several boiler models, the corresponding numbers are shown in the Table. In addition, the number of components is listed.

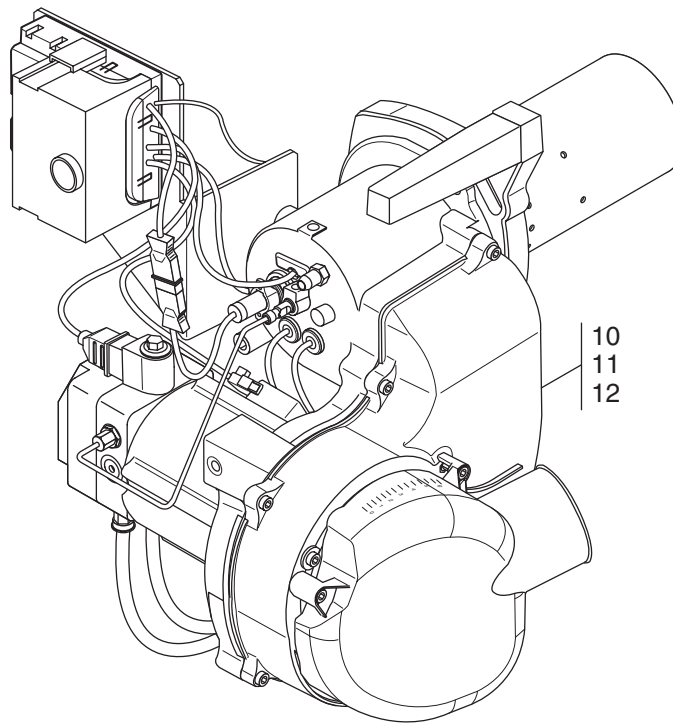

Fig. 37 Burner models BE 1.3 - 2.3

Catalog 7747100486
Designation Burner Models BE 1.3-2.3 (Fig. 37)

Item	Description	Part Number
10	Oil Burner BE 1.3-21	7747005758
11	Oil Burner BE 1.3-28	7747005757
12	Oil Burner BE 2.3-34G	7747005756

Table 14 Burner models BE 1.3 - 2.3

Catalog 7747100487
 Designation Burner Models BE 1.3-2.3 US (Fig. 38)

Item	Description	Part Number
10	Motor HG 150W 120V/60Hz	7747010778
20	Double side coupling	05883147
30	Cylinder screw M5 x 12	7747015963
40	Screw 105 mm M8 x 25 / K105	7747015963
50	Cable race way	63029232
60	Nozzle R 1/8"	05481193
70	Cable race way	05883918
80	Locking stud M6 x 8	7747015963
90	Cylinder screw M8 x 25	7747015963
100	100 distribution cup for BE 21kW/34 kW	63006876
105	Distribution cup for BE 28kW	63032532
110	O-ring	63002998
120	Gasket 128 x 2	63025160
130	Burner flange HG-A	63038318
140	Gasket 143 x 143 x 6 Set V3	7747000719
160	Blower wheel 133 x 38.4 mm for BE 21 kW	63003779
161	Blower wheel 133 x 59.4 mm for BE 28/34 kW	63003780
170	Blower wheel housing HG-A size 1 for 21 kW	63006885
171	Blower wheel housing HG-A size 2 for 28/34 kW	63006886
180	Housing screws M5x20	7747015963
190	Air guiding plate for HG-A size 1 (21 kW)	63006869
191	Air guiding plate for HG-A size 2 (28/34 kW)	63006873
200	200 Air intake sound attenuator	63028801
220	Washer	7747015963
230	Screw DIN912 M5 x 8	7747015963

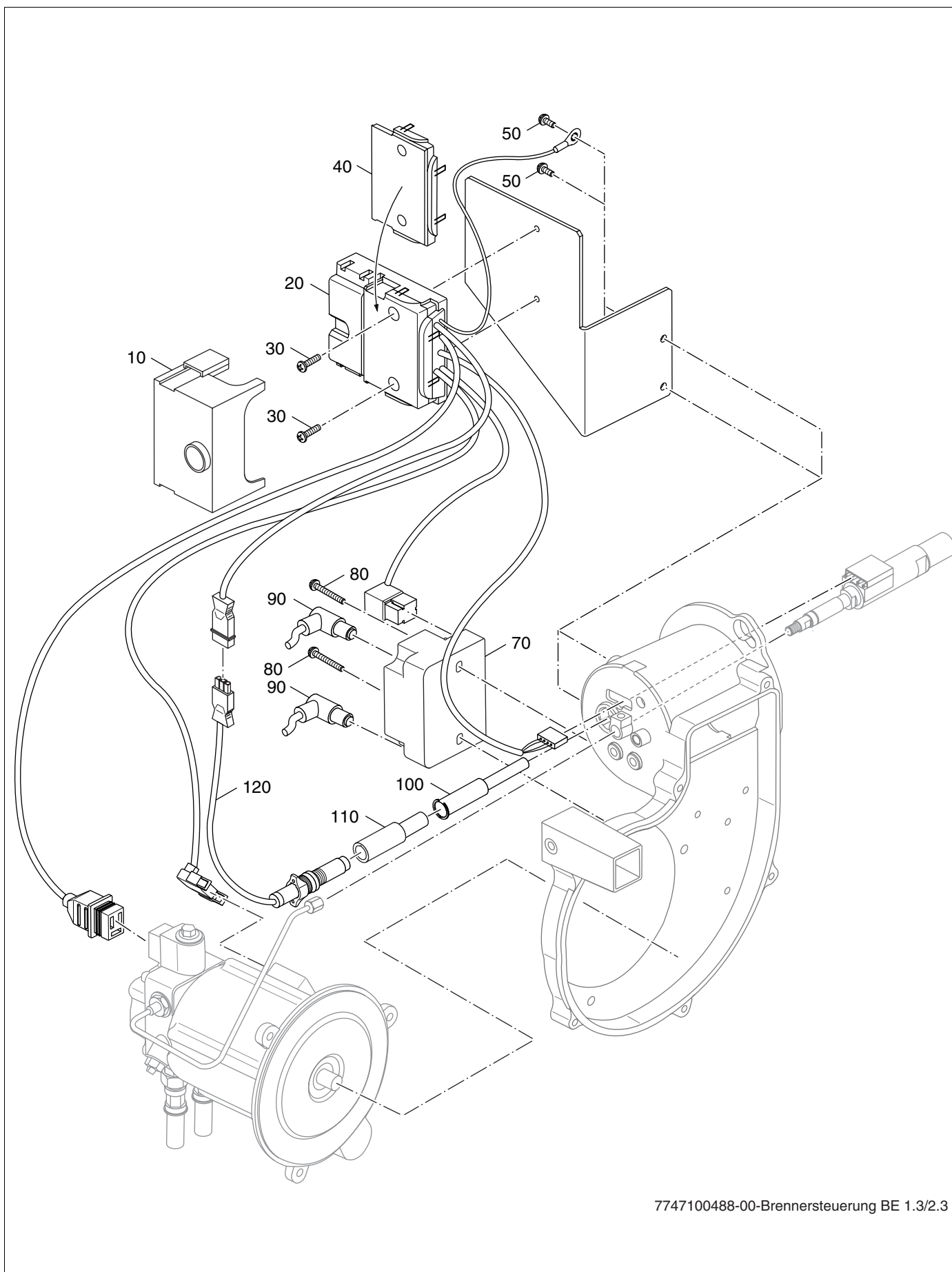

7747100488-00-Brennersteuerung BE 1.3/2.3

Fig. 39 Burner Control BE 1.3-2.3 US

Catalog 7747100488
 Designation Burner Control BE 1.3 - 2.3 US(Fig. 39)

Item	Description	Part Number
10	Burner Primary control LMO 120/60 Hz	7747010788
20	Complete mounting base assembly HG-A 1 stage V5 (no partial components)	63045082
Single Components:		
30	Screw M4x16	7747015963
40	Cover component for HG-A 1-stage	63029996
50	Screw M4x8	7747015963
70	Ignition assembly Beru EZG 120V/60Hz	7747010786
80	Screw M4x50	7747015963
90	Ignition cables BE/BE-A	63006890
100	Mounting pipe HG V4	63045054
110	Mounting pipe extension BE-3 RLU	63032472
120	UV flame sensor QRC 120V/60Hz	7747010789

Table 15 Burner Primary Control BE 1.3-2.3 US

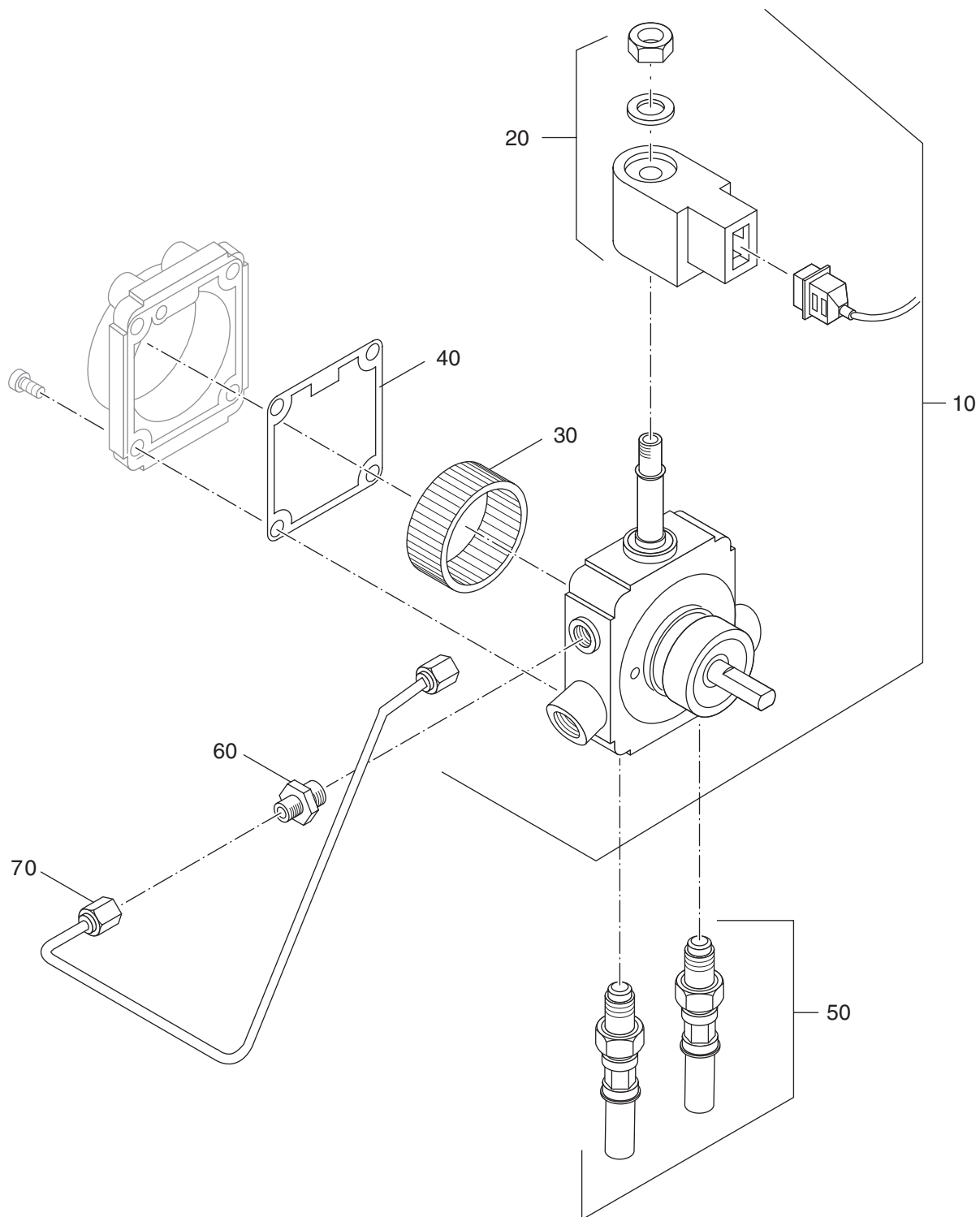

7747100489-00-Ölpumpe Suntec OLE55C BE 1.3/2.3

Fig. 40 Oilpump BE1.3-2.3 US

Catalog 7747100489
 Designation Oilpump BE 1.3-2.3 US (Fig. 40)

Item	Description	Part Number
10	Suntec oil pump OLE35C Rev 6 NA (for BE 1.3-21 and BE 2.3-28)	7747010779
10	Suntec oil pump OLE55C Rev 6 NA (for BE 2.3-34)	7747010781
Single available components		
20	Coil assembly Suntec 120V/60Hz	7747010782
30	Filter A70 rev. 3 for oil pump Suntec AS47	05883218
40	Cover gasket	63016667
50	Hose set straight BE/SE complete	63031508
60	Nipple XGE 4LLR 1/8" straight	05883224
70	Oil tubing complete HG-A	63003054

Table 16 Oilpump BE 1.3-2.3

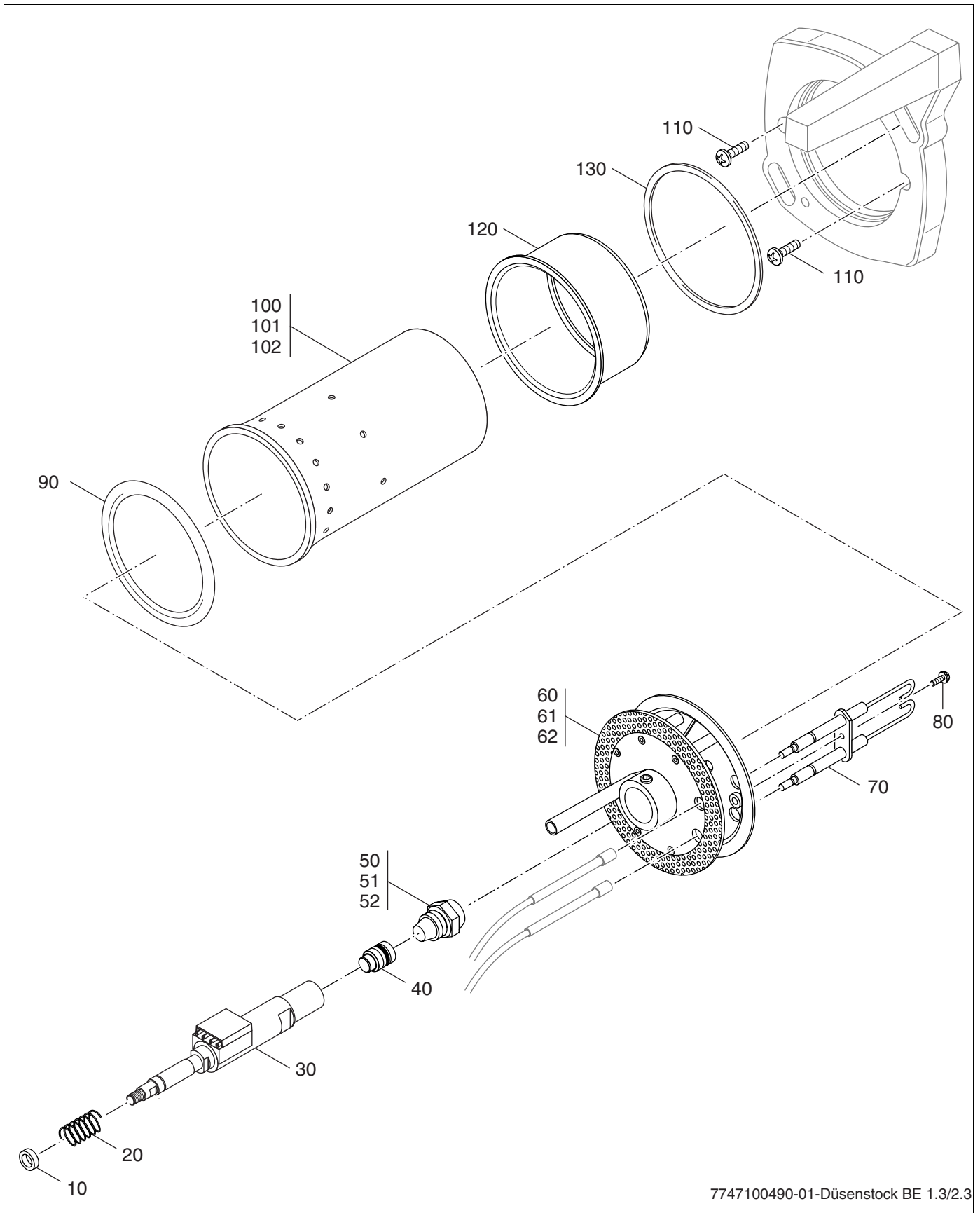

7747100490-01-Düsenstock BE 1.3/2.3

Fig. 41 Complete Nozzle BE1.3-2.3 US

Catalog 7747100490
 Designation Complete Nozzle BE 1.3-2.3 US (Fig. 41)

Item	Description	Part Number
10	Burner tube washer D9.5/14x4mm	63029232
20	Spring DIN2098	7747012279
30	Oil pre-heater assembly FPHB5-LE PTC120	7747010787
40	Membrane valve LE6	63025126
50	Danfoss nozzle .45 gph 80 GR HFD 21 kW	7747009738
51	Danfoss nozzle .55 gph 60 GR HFD 28 kW	7747009739
52	Danfoss nozzle .65 gph 80 GR HFD 34 kW	7747009741
60	Mixing system/diffuser plate assembly BE/BE-A 1.1 21 kW	63006902
61	Mixing system/diffuser plate assembly BE/BE-A 1.1 28 kW	63006903
62	Mixing system/diffuser plate assembly BE/BE-A 1.2 34 kW	63006904
70	Ignition electrode assembly BE/BE-A Typ4 L34	63018295
80	Screw DIN 912 M4x10	7747015963
90	Gasket D81	63037931
100	Burner tube D83/L224/4,3/2,6 SiC für BE 1.3 21kW	63030726
101	Burner tube D83/L224/5,9/4,8 SiC für BE 1.3 28kW	63030727
102	Burner tube D83/L224/7,0/5,7 SiC für BE 2.3 34kW	63030728
110	Burner mounting bolts DIN 7985 M5x10	05883174
120	Locking collar L50	63022595
130	O ring 92x3	63002998

Table 17 Nozzle BE 1.3-2.3 US

12 Glossary

A		
Additive36	
Adjusting oil pressure20	
Adjusting the oil pump pressure20	
B		
Blower wheel26	
Burner connection for 7-pin burner cable	8	
Burner controller LMO11	
Burner failures39	
Burner motor	8	
Burner start-up24	
Burner tube	8	
Burner tube change out29	
C		
Checking the shut-off valve29	
Chimney draft21	
CO ₂ measurement35	
Combustion chamber	10, 11, 18, 35	
D		
Diagnosing faults14	
Disposal	7	
F		
Flame sensor	8	
I		
Inspections and maintenance protocol32	
L		
LMO11	
M		
Measure CO ₂19	
Measuring CO21	
Measuring CO content (carbon monoxide)21	
Measuring CO ₂ -value19	
Messsonde19	
Mixing system	9, 10, 11	
O		
Oil connection38	
Oil Delivery System36	
Oil delivery system38	
Oil nozzle28	
Oil pressure10, 20	
Oil pump	8, 15, 16	
Oil supply lines37	
Original spare parts	6	
P		
Performance values24	
Program sequence (LMO)12	
R		
Recording measured values18	
Replace the oil nozzle20	
Replacement of oil nozzle28	
S		
Shut-off valve29	
Smoke number21	
Spare parts42	
Start-up15	
Suction line	15, 16	
T		
Technical data	9	
Testing for air tightness	34	
Tigerloop	16, 36	
V		
Vacuum	16, 37	
Verifying tightness	35	

BBT North America Corporation
50 Wentworth Avenue
Londonderry, NH 03053
Tel. 603-552-1100
Fax 603-584-1681
www.buderus.net

Products manufactured by
BBT Thermotechnik GmbH
D-35573 Wetzlar
www.buderus.de

BBT North America Corporation reserves the right
to make changes without notice due to continuing
engineering and technological advances.

Buderus