



## Supply and Sound Attenuator Duct Installation Instructions

### GENERAL

The supply and sound attenuator flexible air ducts come in both 2-inch (51mm) and 2 ½ inch (64 mm) inside diameter sizes with 4 options available for increased R-values (see table 1). All models are class 1 air duct listed with ETL per UL-181 and Canadian standard CAN/ULC STD S110-M89. All models are recognized and listed with ICC-PMG to meet building code regulations.

Table 1. Duct R-Factor (English)

Model	Outside Dia, inch [mm]	R-factor °Fhrft <sup>2</sup> /Btu [W/m <sup>2</sup> ·K]	
		Rated*	Effective**
UPC-26C UPC-25	3.5 [89]	3.3 [18.7]	4.0 [22.7]
UPC-26CR4 UPC-25 - R4	4.0 [102]	4.2 [23.8]	5.2 [29.5]
UPC-26CR6 UPC-25 - R6	5.0 [127]	6.0 [34.0]	7.2 [40.9]
UPC-26CR8 UPC-25 - R8	6.0 [152]	8.0 [45.4]	9.1 [51.6]
UPC-226 UPC-225	4.0 [102]	3.3 [18.7]	5.4 [30.6]
UPC-226 R4 UPC-225-R4	4.5 [114]	4.2 [23.8]	7.0 [39.7]
UPC-226 R6 UPC-225-R6	5.5 [140]	6.0 [34.0]	10.3 [58.5]
UPC-226 R8 UPC-225-R8	6.5 [165]	8.0 [45.4]	13.4 [76.1]

\* per ADC Flexible Duct Standard, based on flat thickness, k=.24 Btu-in/h·ft<sup>2</sup>·°F  
 \*\* per ASHARE 2001 Fundamentals Handbook p. 23.21, based on curved thickness  
 Note: Data at 15 ft duct length at 120°F

### INSTALLATION OF UPC-25/225 and UPC-26/226

Tools and Parts required:

- Supply Tubing Clamps or Scrim Core Clamps
- Clamp Pliers (Unico part no. UPC-54)
- Utility knife
- Wire Cutter (for sound attenuator install)
- UL-181B duct tape

Table 2: Clamp Look-up Table

Used With		Clamp Unico P/N	Color	Code (Stamped)
2-Inch	Supply Tubing	UPC-52A	Black	605
	Sound Attenuator	UPC-53B	Silver	575
2 ½ inch	Supply Tubing	UPC-252	Black	725
	Sound Attenuator	UPC-253	Silver	680

Connecting the supply tubing or the sound attenuator to the plenum requires a plenum take-off. Refer to Bulletin 30-50 for the plenum take-off instructions.

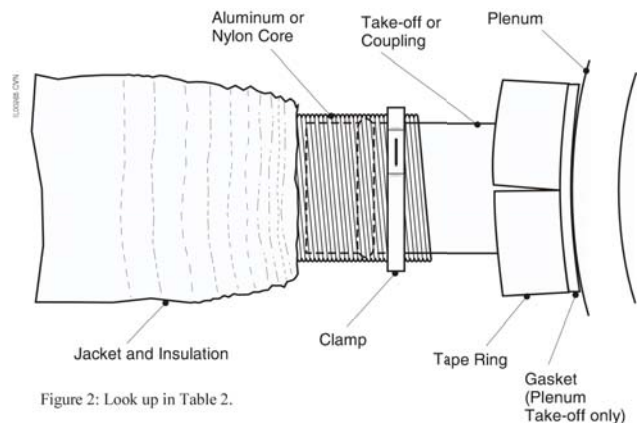

Figure 2: Look up in Table 2.

Table 3: Plenum Take off Table

Duct Size	Plenum	
	Round Metal	Flat Metal
2-Inch	UPC-28	UPC-28F
2 ½ Inch	UPC-228	UPC-228F

Joining two pieces of supply tubing requires a coupling. A coupling is also required to connect the supply tubing to a sound attenuator.

**DO NOT DISCARD PLASTIC TAPE RINGS ATTACHED TO THE TAKE-OFF AND COUPLINGS.** The plastic tape rings will prevent compressing the outer insulation and losing your insulating effect at the connection. Condensation may form on the exterior of the duct if the tape ring is not used.

CONFORMS TO UL STD 181  
CERTIFIED TO  
CAN/ULC STD S110-M86



**STEP 1.** Cut a length of tubing long enough to reach both ends without stretching or placing undue stress on the tubing or connections. The minimum bend radius of the tubing is 6-inches (152-mm).

**STEP 2.** Pull back the insulation of the tubing about 4-inches (102-mm) to expose the inner aluminum or nylon core. Slip a supply or scrim core clamp over the outside of the core. Then slip the core over the end of the take-off or coupling.

*NOTE: "605, 575, 725, and 680" is stamped on the outer rim of the clamp for the supply tubing or the sound attenuator, respectively. See Table 2*

**STEP 3.** Position the clamp and tubing over the ridge or dimple before tightening clamp to prevent the duct from slipping off. Using the clamp pliers, crimp the clamp "ear" to tighten the clamp. Be sure that the pliers reach under the clamp so that the flat portion of the ear is not bent. Crimp with sufficient force to close the clamp but not so much as to cut the clamp.

**ALTERNATE** (for supply tubing installation only): If clamps are not available, use two self-tapping screws to secure the aluminum core to the take-off or coupling.

**STEP 4.** (for supply tubing installation only) Seal the core by wrapping with aluminum tape listed and labeled in accordance with UL-181A and marked "181A-P".

**STEP 5.** Stuff the insulation and outer jacket under the tape ring as best you can. Then seal the outer jacket to the tape ring with tape listed and labeled in accordance with UL-181B and marked "UL-181B-FX".

**STEP 6.** Each duct run should be supported at a minimum of every 6 feet to prevent sagging and bunching of the tube. This will help to reduce restriction within the duct and allow for the most efficient air flow.

**INSTALLATION OF UPC-26CR6 AND UPC-26CR8**

The R-6.0 duct will not compress enough to push through the 4-inch hole for the supply outlet. Connect a 2 ft. (610 mm) length of R-4.2 duct to the outlet and couple it to the R-6.0 duct. The R-4.2 duct will pass through the 4-inch hole. If R-6.0 duct is to be maintained throughout the entire length of attenuator, wrap an additional 1-inch fiberglass blanket around the R-4.2 duct after the supply outlet has been attached to the surface.

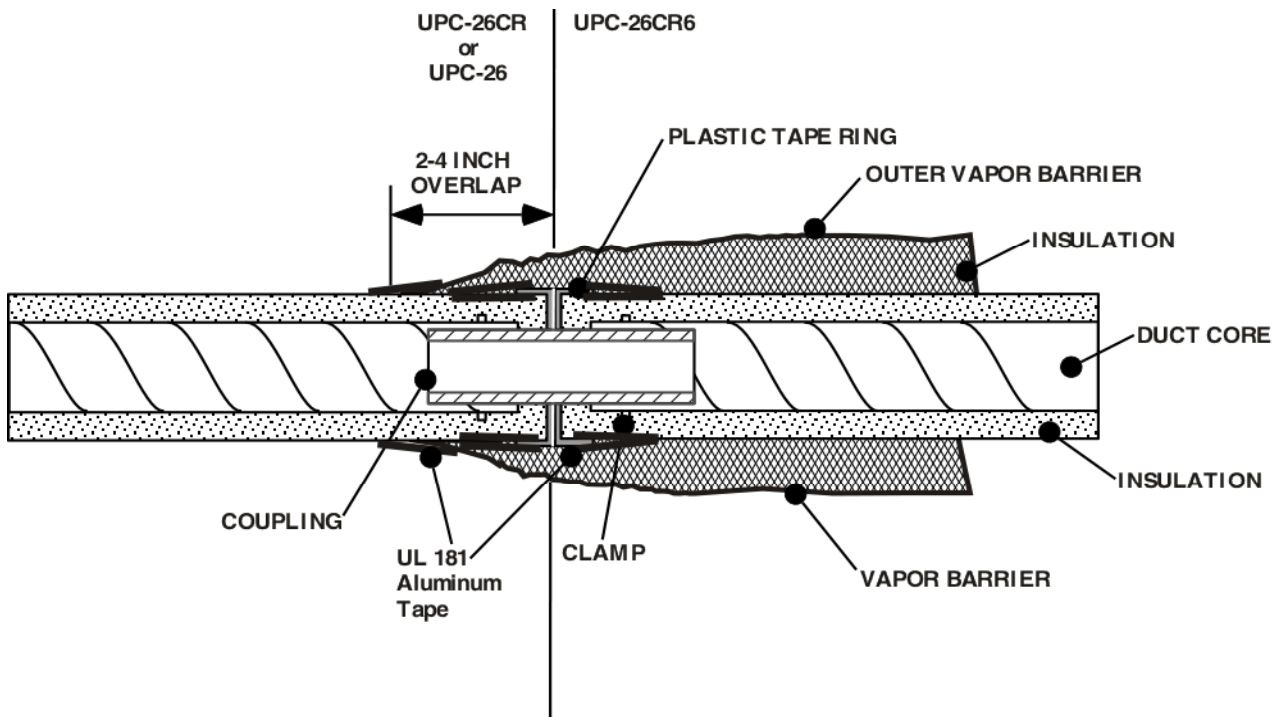

**Figure 2. Detail of Duct Connection**