



INSTALLATION INSTRUCTIONS

Replacement Combustion Chamber Kit
H.B. Smith Series 8
Hydrotherm PB Series
Oil Fired Boilers

Lynn Manufacturing, Inc
15 Marion St., Lynn, MA 01905
TEL:781-593-2500 FAX:781-596-0430

1104

Fits all models WITHOUT Swing-Out Door

WARNING This product contains fiberglass and ceramic fiber materials. Airborne fibers from this material have been listed by the State of California as a possible cause of cancer through inhalation. Apply special care when handling these materials. (Burner door refractory, target wall, rope seal and blanket)

Please see MSDS for more health and safety information.

BEFORE STARTING: **WARNING** Failure to perform the following can cause severe personal injury, death or substantial property damage!

- * Read all instructions before starting.
- * Follow all instructions in proper order.
- * Turn off service switch on boiler and all other electrical disconnect switches.
- * Close fuel supply valve(s) and disconnect fuel line from burner.

REMOVAL:

1. Check to make sure all electric power is off, and the oil line is disconnected.
2. Remove Burner Mounting Plate and oil burner.
3. Remove the old Target wall, floor blanket, and front refractory.
4. Clean-out the combustion area.

INSTALLATION:

5. Insert the new target wall through the boiler opening, and press it into position against the backwall of the boiler. The target wall should be a tight press fit into the back section of the boiler. If it is loose, place the ceramic fiber paper shims provided between the target wall and the casting to insure a tight fit.
6. Measure the distance from the front of the target wall to the front of the boiler and cut the 16" wide Kaowool blanket provided to this length.
7. Open the bottle of waterglass and spread the contents on the boiler floor.
8. Place the blanket on the floor of the boiler. Make sure it is up against the bottom lip of the target wall and centered from side to side.
9. Press the new front refractory into the burner mounting plate.
10. Replace the rope seal around the burner mounting plate.
11. Reinstall the burner mounting plate and oil burner.
12. Reconnect and turn on the oil line and electric power.
13. Fire the burner for 15 min. to allow chamber to "cure".

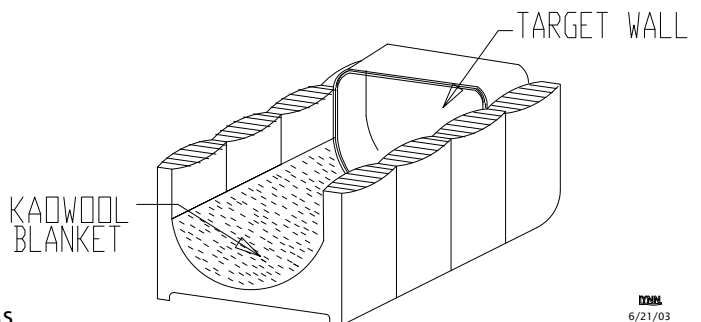
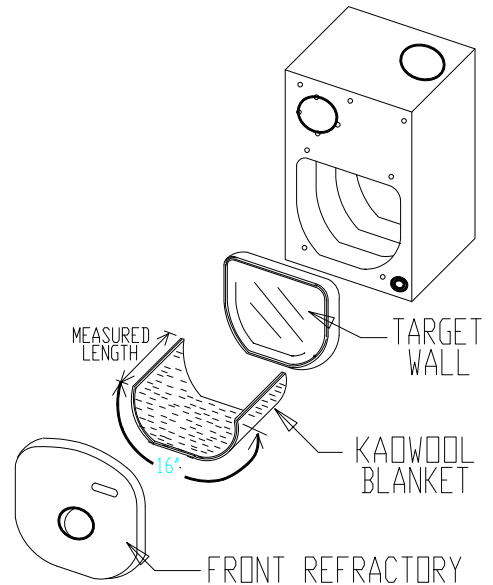

NOTE: WHEN FIRST FIRED, SOME SMOKE AND A SLIGHT ODOR WILL OCCUR. THIS IS PART OF THE CURING PROCESS.

14. Combustion tests **MUST** be performed **AFTER** the curing process is complete to insure proper performance.