



MODEL HW-ECM INSTALLATION, OPERATION & MAINTENANCE MANUAL



Low Temperature
High Wall Heating/Cooling Fan Coil
Units up to 2 Ton Capacity



A. General Description.....	2	D. Control Specifications: Complete Control PCB -	
B. Technical Data.....	3-5	S Type Control	10-14
General Specification.....	3	Definition of Input/Output	10
Coil Data	4	Wiring Diagram Full Control PCB – S Control Type	11
Sound Power and Pressure Data	4	Configuration Settings	12
Dimensional Drawings	5	Control Logics for 2-Pipe System	13
C. Service and Installation.....	6-11	With Thermoelectric Valve Configuration.....	13
Installation of High-Wall Unit.....	6	Sleep Mode.....	14
Selecting a Location	6	Auto Fan Speed.....	14
Mounting Plate Dimensions	7	LED Lights	14
Installing the Mounting Plate.....	7	LED Display and Error Description	14
Drilling the Condensate Drainage Hole	8	E. Users Interface.....	15
Installing the Hydronic Unit	8	Remote Control Handset	15
Drainage Piping Works	8	F. Sensor Resistance R-T Conversion Table.....	16-17
Unit Maintenance and Preparation	9	G. Troubleshooting Guide	18
Opening and Closing of Lift-Up Grille Cover.....	9	H. Replacement Parts	19
Removing Front Cover Assembly	9		
Air Purging	9		
Wiring Connections.....	9		

INVESTING IN QUALITY, RELIABILITY & PERFORMANCE.

ISO 9001 QUALITY



Every product is manufactured to meet the stringent requirements of the internationally recognized ISO 9001 standard for quality assurance in design, development and production.

World Leading Design and Technology

Equipped with the latest air-conditioning test rooms and manufacturing technology, we produce over 50,000 fan coil units each year, all conforming to the highest international standards of quality and safety.

ETL SAFETY STANDARDS



All products conform to UL standard for Safety for Heating and Cooling Equipment UL1995 4th Edition, October 14, 2011;

All products conform to CSA standard for Safety for Heating and Cooling Equipment CSA C22.2 No.236-11, 4th Edition, October 14 2011.

The Highest Standards of Manufacturing

In order to guarantee the very highest standards and performance, we manage every stage in the manufacturing of our products. Throughout the production process we maintain strict control, starting with our extensive resources in research and development through to the design and manufacture of almost every individual component, from molded plastics to the assembly of units and controllers.

WEEE MARK



All products conform to the “WEEE” directive to guarantee correct standards of environmental solutions.

Quality Controlled from Start to Finish

Our highly-trained staff and strict quality control methods enable us to produce products with an exceptional reputation for reliability and efficiency, maintained over many years. As well as full CE certification and ISO 9001, several products ranges have UL / ETL safety approval in the USA and Canada, Eurovent performance and sound certification as well as ROHS compliance for Europe, giving you the confidence of knowing our company is the right choice when selecting fan coil units.

ALWAYS MAKE SURE THIS MANUAL REMAINS WITH THE UNIT. READ THIS MANUAL BEFORE PERFORMING ANY OPERATION ON THE UNIT.

A. General Description

This HighWall Unit is designed to meet and exceed demanding requirements for efficiency, quiet operation and appearance. The sleek profile and elegantly styled cabinet complements any interior design theme, while the microprocessor assures accurate environmental control.

Cabinet - the stylish cabinet is constructed of durable flame resistant acrylonitrile-butadiene-styrene (ABS) plastic. The silver white color and rounded corners provide its modern look.

Water Coil - the water coil has a large heat transfer surface and utilizes the latest fin profile technology. It combines an advanced technology approach with the security of a traditional design regarding tube thickness. The water coil is also equipped with an air vent valve and a water purge valve.

Integral Hoses - an integral hose is a synthetic elastomer tube, with stainless steel outer braiding and brass connectors, which enables quick, low cost connections with no brazing.

Blower and Motor - the unit incorporates only specially designed and tested EC motors, allowing the blower wheel to provide optimum performance in airflow-efficiency and quiet operation.

Filters - washable, easy-to-remove, fine mesh air filters are standard to all HighWall models. Tabs located on the front of the unit can be unsnapped, allowing the filter to be easily slid downward and removed. No tools are required, nor any dismantling of the equipment.

Air Grille Distribution - all units are equipped with both deflector blades and independent directional vanes, enabling supply air to be automatically distributed, and air flow and direction to be customized.

Microprocessor controls (S3 type)

The PCB (printed circuit board) Modbus microprocessor controls functionality of the indoor-fan motor and water valves (ON/OFF or modulating) to maintain room conditions at a user-defined set point. Temperature settings, fan speeds and other control functions can be changed by either infrared handset or wired wall pad.

- High efficiency EC motor.
- Cool, Heat, Auto, Dehumidifier and Fan modes.
- Sleep, Auto-Fan, Daily Timer, Auto-Restart with memory functions.
- User friendly remote control.
- Heat and cool temperature protections and safety cut out.
- Manual control panel in cabinet.
- Auxiliary switch for cooling and heating signal.

B. Technical Data

General Specification – HW-ECM Series

Product range: HW-ECM Hydronic High Wall 2 Pipe with EC Motor

Unit Configuration				Configuration				
				Number Of Fan Blowers				
				HW-06-ECM	HW-15-ECM	HW-18-ECM		
Performance Data	Air	Air Flow	H	CFM	294	379	464	
			M		218	294	435	
			L		171	218	335	
	Cooling	Cooling Capacity	H	BTU/Hr*	6968	10199	12590	
			M		6151	9011	11132	
			L		4866	7136	8813	
		Sensible Cooling Capacity	H		4817	7031	8686	
			M		3754	5659	7507	
			L		3107	4202	6080	
	Heating	Heating Capacity	H	BTU/Hr*	13961	20436	25227	
			M		10832	15856	19572	
			L		7712	11302	13952	
	Electrical	Fan motor power	H	W	18	22	30	
			M		13	15	20	
			L		10	10	13	
		Voltage	V/Ph/Hz		115/1/60			
	Fan Motor Running Current @ H 115V		A		0.31	0.38	0.52	
	Sound	Sound Pressure Level H/M/L		dB(A)		39/31/26	45/34/31	49/44/37
	Hydronic	Water Flow Rate	H	GPM	1.39	2.03	2.52	
			M		1.1	1.68	2.2	
			L		0.92	1.26	1.81	
		Pressure Drop	H	Ft.wg	7.9	9.7	13.5	
			M		5.3	6.9	10.8	
			L		3.9	4.3	7.6	
Heating Pressure Drop		H	Ft.wg	7	9	12		
		M		4.8	6.2	9.7		
		L		3.5	3.8	6.9		
Volume		gal		0.02	0.03	0.05		
Connections		Type		NPT Threaded Male				
		In	in	1/2				
	Out	5/8						
Condensate Drainage Connection								
Net Weight		lbs		26.5	28.7	30.9		

a. Cooling:
Return air temperature: 80°F DB/67°F WB.
Inlet/Outlet water temperature: 45°F/55°F

b. Heating Return air temperature:
70°F Inlet water temperature: 140°F

*Heating: water temperature difference is 20°F.
Cooling: water temperature difference is 10°F.

Coil Data – 2-Pipe Systems

Model	Fin Height (inch)	Fin Length (inch)	Fins per Inch	No. of Rows	No. of Copper	No. of Circuits	Tube Diameter (inch)
HW-06-ECM	9.1	26.8	19.5	2	14	3	0.3
HW-15-ECM	9.1	26.8		2	22	4	0.3
HW-18-ECM	14.1	26.8		2	34	5	0.3

Sound Power Data

Model		HW-06-ECM			HW-15-ECM			HW-18-ECM		
Speed (CFM)		H(930)	M(700)	L(600)	H(1150)	M(800)	L(700)	H(1300)	M(1100)	L(900)
Sound Power in 1/3 Octave-bands under ESP: 0Pa	Sound Power dB(A)	49.0	39.8	35.7	56.0	43.9	39.5	60.0	54.5	47.5
	20.0 Hz	15.8	19.8	17.1	21.1	19.9	19.9	14.7	23.8	19.0
	25.0 Hz	14.0	19.5	17.2	22.6	19.7	17.7	21.4	17.9	17.9
	31.5 Hz	23.2	16.6	21.8	22.7	16.3	18.4	21.2	17.9	19.1
	40.0 Hz	19.9	14.8	13.4	23.6	16.3	17.6	28.1	19.1	17.6
	50.0 Hz	22.0	17.8	16.6	20.3	20.2	18.9	23.2	26.0	20.8
	63.0 Hz	24.7	19.8	16.7	28.4	23.4	20.8	34.4	29.1	23.3
	80.0 Hz	26.1	20.3	12.4	32.1	21.0	21.8	38.8	31.2	26.0
	100.0 Hz	28.6	22.8	17.7	36.0	24.2	22.1	39.4	37.2	27.6
	125.0 Hz	32.1	26.3	25.9	38.0	27.3	26.3	43.2	34.6	28.8
	160.0 Hz	34.4	26.1	17.8	39.8	30.0	23.4	44.5	37.0	31.8
	200.0 Hz	33.2	26.0	17.7	39.2	29.6	23.9	44.6	37.5	31.3
	250.0 Hz	31.7	25.0	20.0	39.6	28.1	26.5	43.5	36.9	30.8
	315.0 Hz	35.2	25.6	22.1	40.9	30.5	25.7	45.0	40.4	34.3
	400.0 Hz	39.9	32.0	26.2	46.2	36.2	31.7	50.5	45.1	38.0
	500.0 Hz	42.3	31.1	25.1	47.5	37.9	32.4	50.9	46.3	41.3
	630.0 Hz	42.2	29.7	24.6	48.8	35.4	30.7	52.3	49.5	39.7
	800.0 Hz	37.6	27.9	22.6	46.5	32.8	28.2	50.8	44.4	37.2
	1000.0 Hz	39.5	28.6	23.1	48.5	33.6	28.8	52.6	45.7	39.1
	1250.0 Hz	36.3	24.7	21.0	45.2	30.5	24.3	49.1	43.9	35.0
1600.0 Hz	32.8	22.6	21.6	42.7	26.7	22.8	47.1	39.4	31.3	
2000.0 Hz	29.6	20.8	19.8	39.4	23.4	21.2	44.4	36.8	28.0	
2500.0 Hz	26.9	20.9	20.0	36.7	22.2	20.4	41.6	34.1	25.9	
3150.0 Hz	24.5	20.9	20.7	33.3	21.9	20.9	38.3	31.3	23.7	
4000.0 Hz	23.1	20.8	20.8	31.5	21.3	20.7	36.6	29.5	22.9	
5000.0 Hz	21.8	20.7	20.6	27.8	20.9	20.6	32.7	25.9	21.6	
6300.0 Hz	20.5	20.2	20.0	24.5	20.3	20.2	29.1	23.1	20.4	
8000.0 Hz	19.2	19.2	19.1	21.2	19.2	19.1	24.6	20.5	19.3	
10000.0 Hz	17.2	17.5	17.3	17.9	17.3	17.2	19.5	17.7	17.3	
12500.0 Hz	14.3	14.5	14.4	14.6	14.4	14.5	15.3	14.5	14.4	
16000.0 Hz	11.6	11.2	11.2	11.9	11.3	11.3	11.9	11.4	11.6	

Dimensional Drawings – HW-06/15/18-ECM - (Inches)

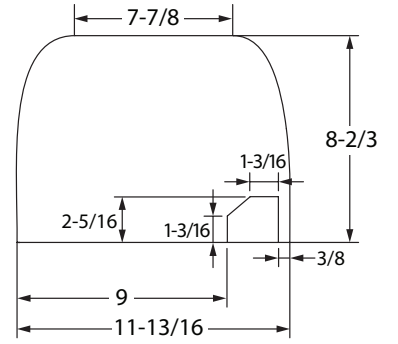
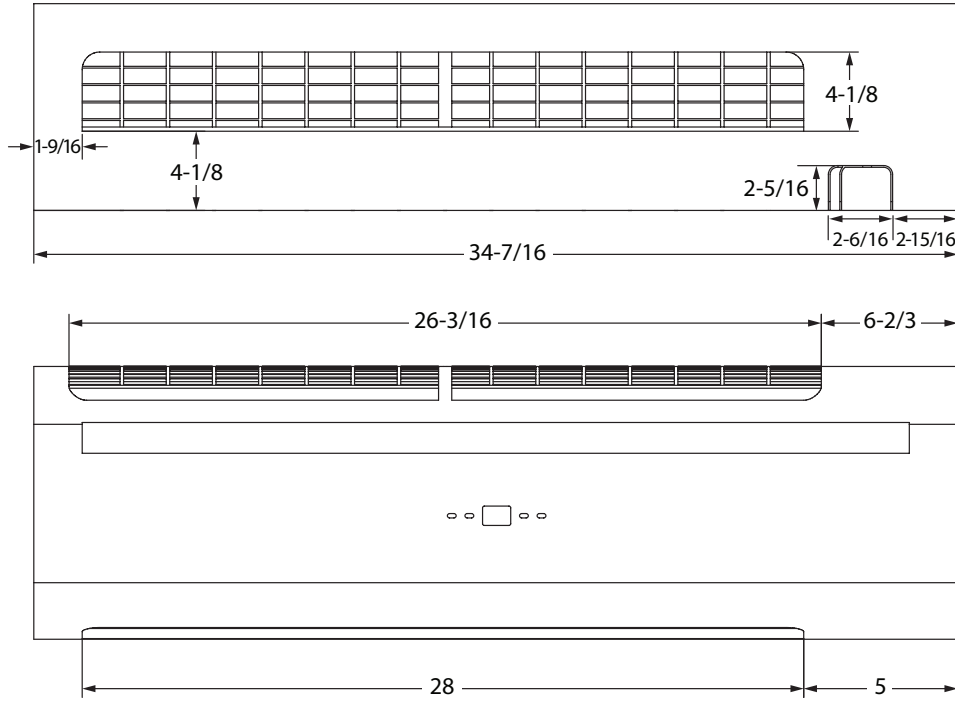

C. Service and Installation

Operating Limits

Power Supplies

Volt	Phase	Hz
110-120	1	60

Water Circuit

Minimum entering water temperature	35.6°F (+2°C)
Maximum entering water temperature	160°F (+71°C)
Water side recommended maximum pressure	250 PSI (1724 kPa)

Installation of HighWall Unit

Selecting a Location

Select the location for the HighWall unit with the following considerations:

1. The air inlet and outlet area should be clear without obstructions. The air should flow freely.
2. The HighWall unit should be mounted on solid wall.
3. The location should allow easy access to connect water pipes easily achieve drainage.
4. Ensure the clearance around the fan coil unit conforms to the following drawing.
5. The unit should be installed higher than eye level.
6. Avoid installing the unit with direct sunlight.

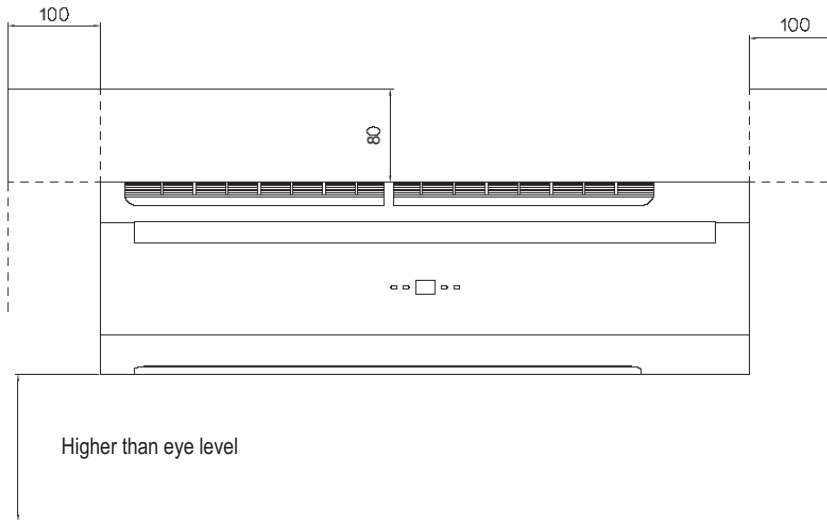

Notes:

Required clearance for maintenance and servicing is as shown above.
All dimensions shown in inches.

7. The signal receiver on the unit must be kept away from any high frequency emission source.
8. Keep the unit away from fluorescent lamps, which may affect the control system.
9. Avoid electromagnetic control system interference, ensure control wires are installed separately from 110 VAC power supply wires.
10. Use shielded sensor cables where electromagnetic waves present.
11. Install a noise filter if the power supply creates any disruptive noises.

Mounting Plate Dimensions

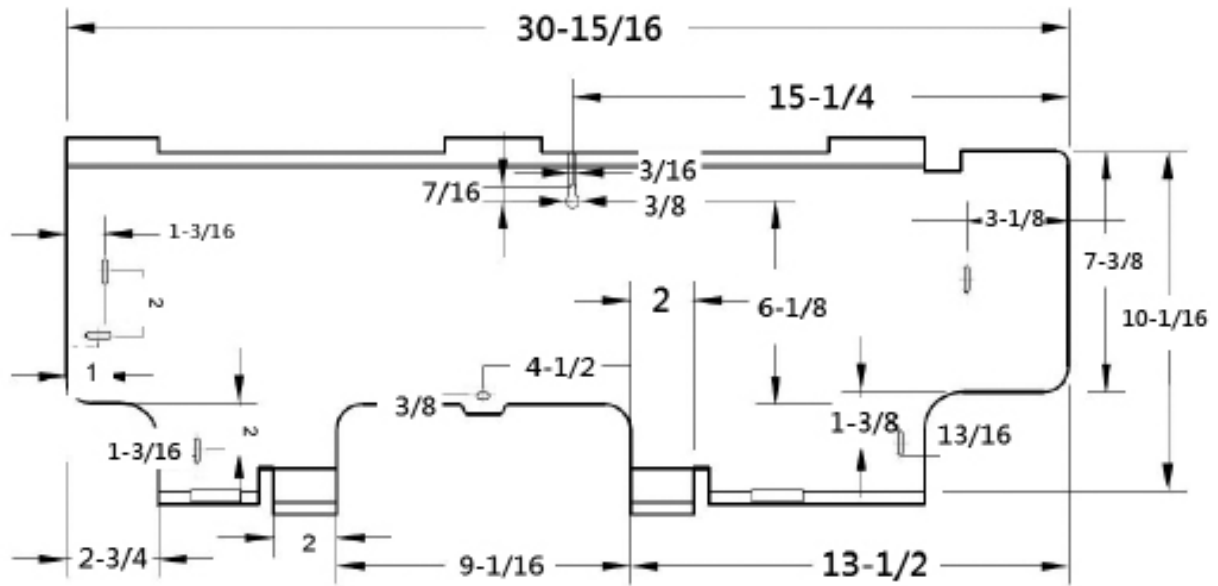

(All dimensions are in inches)

Installing the Mounting Plate

1. Select the structural position (e.g. a pillar or lintel) on the wall.
2. Then temporarily fasten the mounting plate on the wall with a steel nail.

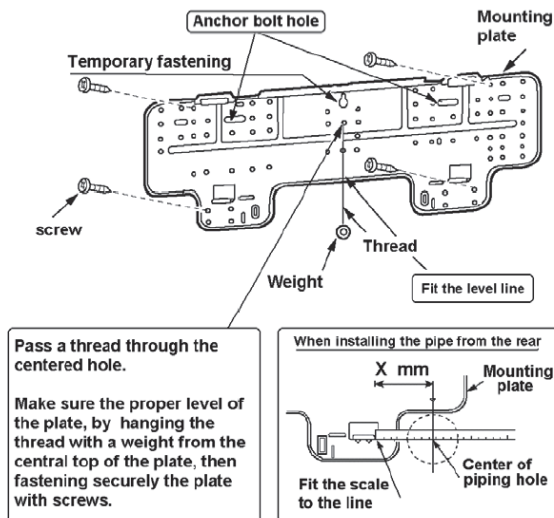

3. Mount the mounting plate horizontally as shown in the above figure or by means of gradiometer. Failure to follow this may cause water to drip indoors and create atypical noise.
4. Fix the mounting plate by means of expansion screws or tapping screws.



Drilling the Condensate Drain Hole

1. Ensure that the hole for condensate drain is correctly positioned. The height should be lower than the bottom edge of the indoor unit.
2. Drill a 2.5" diameter hole with a descending slope.
3. Seal it off with putty after installation.

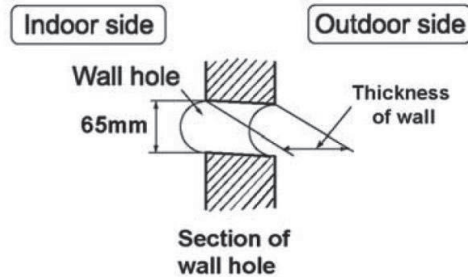

Installing the Hydronic Unit

1. Pass the piping through the hole in the wall and hook the indoor unit on the mounting plate by the upper hooks.
2. Move the body of the unit from side to side to verify if it is securely fixed.
3. While pushing the unit toward the wall, lift it slightly from beneath to hook it up on the mounting plate by the lower hooks.
4. Make sure the unit firmly rests on the hooks of the mounting plate.

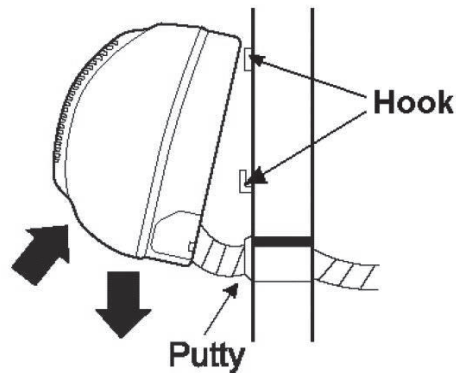

Drain Piping Works

1. Install the drain hose so that it slopes downward slightly for free drainage. Avoid installing it as shown in the below illustrations marked with an "X".

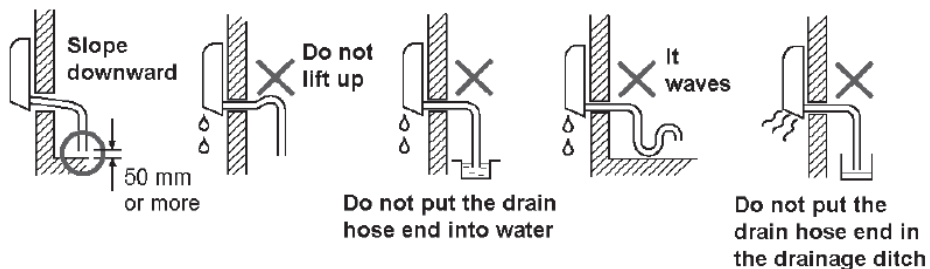

2. Put water in the drain pan and make sure that the water drains outdoors.
3. If the flexible drain hose provided with the indoor unit is not long enough, please extend it by joining it to a field supplied extension. Be sure to insulate the connecting part of the extension with a shield pipe as shown.

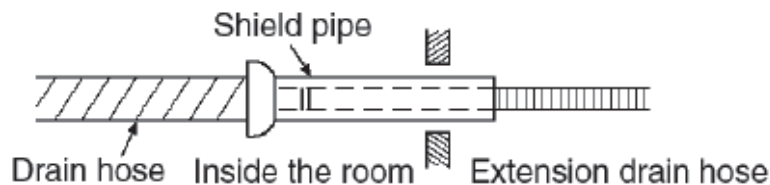

4. If the attached drain hose passes through an indoor area, insulate it with insulation material.

Unit Maintenance and Preparation

Opening and Closing Of Lift-Up Grille Cover



Open the grille cover by lifting from the bottom position indicated by the arrows.

Close the grille cover by pressing down at the positions indicated by the arrows.

Removing Front Cover Assembly

1. Set the horizontal louver to the horizontal position.
2. Remove the screw caps below the louver, and then remove the mounting screws.
3. Open the lift-up grille cover by grasping the panel at both sides as shown above.
4. Remove the remaining screws located in the center of the front cover.
5. Grasp the lower part of the front cover and pull the entire assembly out and up towards you.

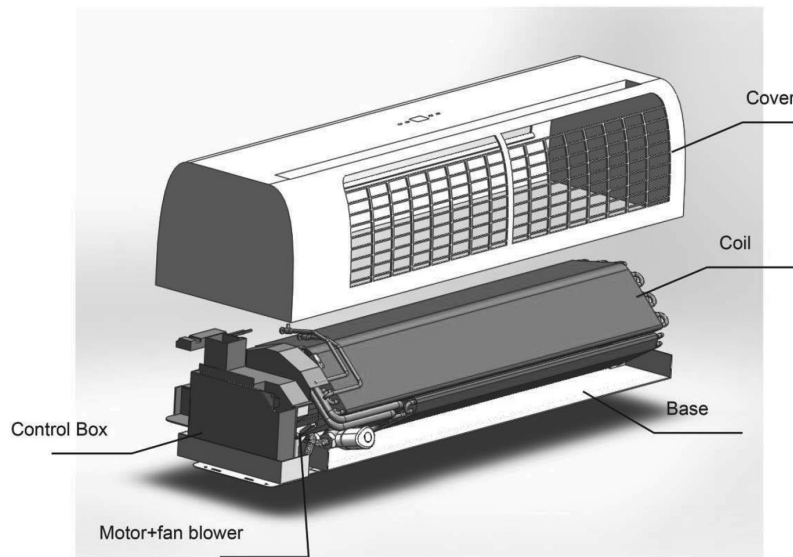

Air Purging

1. After connecting the water inlet and outlet pipes to the main supply lines turn on the main breaker and operate the unit in COOLING mode.
2. Open the water inlet valve and flood the coil.
3. Check all connections for water leakage. If no leak is found, open the purging valve with an open end wrench while supporting the unit with your other hand. Then purge the air trapped inside the coil. When performing this activity, take care not to touch the electrical parts.
4. Close the purging valve when no bubbles appear.
5. Open the water outlet valve.

Wiring Connections

Unit components are wired to the terminal block of the indoor unit. Wiring can be accessed from the terminal block inside the control box.

D. Control Specifications: Complete Control PCB - S Type Control

Abbreviations

Ts = Setting temperature

Tr = Room air temperature

Ti1 = Chilled water coil temperature

Ti2 = Hot water coil temperature

AUX1 = Hot water free contact

AUX2 = Chilled water free contact

MTV1 = Chilled Motorized valve

MTV2 = Hot Motorized valve

Definition of Input/Output

	I/O	Code	2-Pipe
Analogue Input	Return air sensor	AI1	Return air temperature (Tr)
	Coil sensor	AI2	Chilled / hot water coil circuit (Ti1)
Input	LED display / IR reciever	DIS1	Digital communication port to LED display / IR receiver board.
Digital input	Occupancy contact	On/Off	Window contacts: for remote ON/OFF (when DIPB SW1 = 1). Economy contacts: for remote activation of economy mode (when DIPB SW1 = 0).
Power input	Phase	L1	Power supply: 115V/1Ph/60Hz
	Neutral	N1	
	Earth		
Voltage output	Fan	CN4	Fan driver
	Valve 1	MTV1	2-pipe coil circuit valve output - chilled / hot water valve. Voltage output (L)
	Valve 2	MTV2	Reserved
Output	Stepping motor	CN1 / CN2	Louver stepping motor relay
	Auxiliary contact 2	AUX2	Cooling mode signal relay (NO). Voltage free contact. To ensure the sensitivity of the connection, please make sure max wiring length < 100ft.
	Auxiliary contact 1	AUX1	Heating mode signal relay (NO). Voltage free contact. To ensure the sensitivity of the connection, please make sure max wiring length < 100ft.

Wiring Schematic

ABG-S1.1

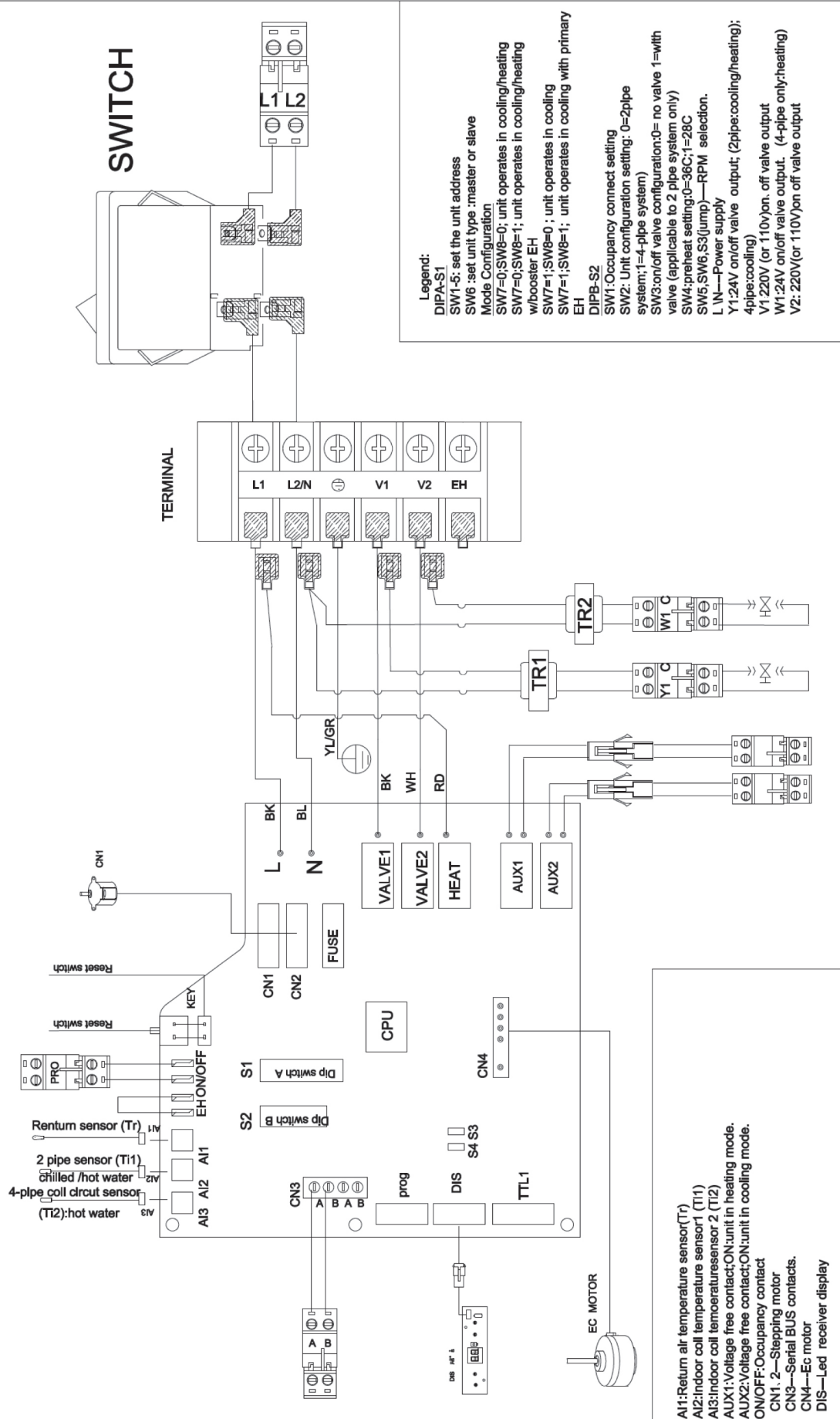

Motorized Fan Speed Settings for Different Models on DIPB:

Unit Model	Speed (RPM)		
	Low	Medium	High
HW-06-ECM	600	700	900
HW-15-ECM	700	800	1100
HW-18-ECM	900	1100	1300
Default RPM	900	1200	1350

Mode configuration:

DIPA-S1		Model
SW7	SW8	Model setting
0	0	Cool-Heat
0	1	Cool-Heat + booster heater
1	0	Cooling only
1	1	Cool + primary heater

HighWall Unit ON/OFF

There are 3 ways to turn the system on or off:

- a) By the ON/OFF button on the handset.
- b) By the programmable timer on the handset.
- c) By the manual control button on the HighWall unit.

Power On Setting

There are 3 ways to turn the system on or off:

- a) Handset only user interface: When the power ON signal is received by the unit, the Mode, Fan Speed, Set temperature and Louver setting will be the same as the handset setting before the last power OFF.
- b) When the power ON signal is received by the HighWall unit, the Mode, Fan Speed, Set temperature, Louver setting and Timer ON/OFF weekly program will be the same as the handset setting before the last power OFF.

Control Logics For 2-Pipe System (Standard Unit)

With Thermoelectric Valve Configuration

COOL MODE

- a) MTV2, AUX1 and heater are always off.
- b) If $T_r \geq T_s + 1.8^\circ\text{F}$ (or $+ 7.2^\circ\text{F}$ if economy contact is activated), then cool operation is activated and MTV1 and AUX2 are turned on. Indoor fan runs at set speed.
- c) If $T_r < T_s$, then cool operation is terminated and MTV1 and AUX2 are turned off. Indoor fan runs at set speed.
- d) The range of T_s is $60.8 - 86^\circ\text{F}$
- e) Indoor fan speed can be adjusted to low, medium, high and auto.
- f) When turned on, MTV1 requires 30 seconds before it is fully open.
- g) When turned off, MTV1 requires 120 seconds before it is fully closed.
- h) When the unit is turned off, the indoor fan will shut down after 5 seconds.

LOW TEMPERATURE PROTECTION OF INDOOR COIL

- a) If $T_{i1} \leq 35.6^\circ\text{F}$ for 2 minutes, then MTV1 and AUX2 are turned off. If indoor fan is set for low speed, it will run at medium speed. If it is set at medium or high speed, it will keep running at the same speed.
- b) If $T_{i1} \geq 41^\circ\text{F}$ for 2 minutes, then MTV1 and AUX2 are turned on. Indoor fan runs at set speed.

FAN MODE

- a) Indoor fan runs at the set speed while heater, MTV1, MTV2, AUX1 and AUX2 are turned off.
- b) Indoor fan speed can be adjusted to low, medium and high.

PRE-HEAT

- a) If $T_{i1} < 96.8^\circ\text{F}$ (or 82.4°F depending on DIP setting), then MTV1 and AUX1 are turned on, indoor fan runs at 200RPM.
- b) If $T_{i1} \geq 100.4^\circ\text{F}$ (or 86°F depending on DIP setting), then MTV1 and AUX1 are turned on, indoor fan runs at set speed.
- c) If the indoor coil temperature sensor is damaged, then the pre-heat time is set for 2 minutes. Indoor fan runs at set speed.

POST-HEAT

- a) If $T_{i1} \geq 100.4^\circ\text{F}$, then MTV1 and AUX1 are turned off. Indoor fan continues to run at set speed.
- b) If $96.8^\circ\text{F} \leq T_{i1} \leq 100.4^\circ\text{F}$, then MTV1 and AUX1 are turned off. Indoor fan maintains its original state.
- c) If $T_{i1} < 96.8^\circ\text{F}$, then MTV1 and AUX1 are turned off. Indoor fan runs at 200RPM.
- d) If the indoor coil temperature coil is damaged, then the post-heat time is set for 3 minutes with the indoor fan running at set speed.

OVER-HEAT PROTECTION OF INDOOR COIL

- a) If $T_{i1} \geq 167^\circ\text{F}$, then MTV1 and AUX1 are turned off. Indoor fan remains on and runs at high speed.
- b) If $T_{i1} < 158^\circ\text{F}$, then MTV1 and AUX1 are turned on. Indoor fan remains on and runs at set speed.
- c) If the indoor coil temperature sensor is damaged, then the protection mode will be overridden and the unit will work according to the pre-heat and post-heat program.

DEHUMIDIFICATION MODE

- a) MTV2, AUX1 and heater are always off.
- b) If $T_r \geq 77^\circ\text{F}$, then MTV1 and AUX2 will be turned on for 3 minutes, and then off for 4 minutes.
- c) If $60.8^\circ\text{F} \leq T_r < 77^\circ\text{F}$, then MTV1 and AUX2 will be turned on for 3 minutes, and then off for 6 minutes.
- d) If $T_r < 60.8^\circ\text{F}$, MTV1 and AUX2 will be turned off for 4 minutes.
- e) At the end of the above dehumidification cycle, the system will decide the next dehumidification control option. Indoor fan will run at low speed throughout the dehumidification process.

AUTOMODE

- a) Every time the unit is turned on, MTV1 is on while AUX1, AUX2 and fan are off. MTV2 and the heater are always off. After 120 seconds, the subsequent operation mode is decided according to the following:
 - i. If the coil temperature sensor (T_{i1}) $\geq 96.8^\circ\text{F}$, then MTV1, AUX1 and fan turn on or off according to HEAT mode.
 - ii. If $T_{i1} < 96.8^\circ\text{F}$, then MTV1, AUX2 and fan turn on or off according to COOL mode.
- b) Unit remains in AUTO COOL or AUTO HEAT mode throughout the operating cycle until the user changes the mode manually or restarts the unit.
- c) Should the T_{i1} sensor fail or be damaged, auto mode will not function.

Note: AUTO COOL or AUTO HEAT operations are the same as COOL or HEAT mode respectively.

Sleep Mode

- The sleep mode can only be set when the unit is in cool mode or heat mode.
- If the sleep mode is activated when the unit is in cool mode, then the indoor fan will run at low speed and T_s will increase by 3.6°F over 2 hours.
- If the sleep mode is activated when the unit is in heat mode, then the indoor fan will run at set speed and T_s will decrease by 3.6°F over 2 hours.
- Changing the mode of operation will cancel the sleep mode.

The cool mode sleep profile is:

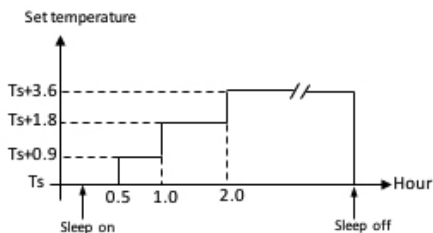

The heat mode sleep profile is:

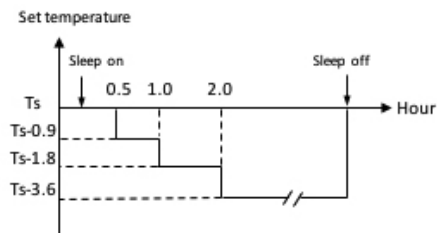

Auto Fan Speed

In this mode, the fan speed is not changed until the fan has run for more than 30 seconds. After 30 seconds the fan speed is modulated according to the difference between the room temperature and the set temperature. The controller adjusts the motor signal input from 0 to 5VDC by PID calculation every 10 seconds. The air flow is adjusted from 15% to 100%.

LED Lights

For all units	
Power / Operation LED light (both green)	
Unit on	Power LED Off, Operation LED On
Unit in standby	Power LED On, Operation LED Off

LED Display and Error Description

For all units - Operation LED light (Green)				
Blink	LED Display	Error Description	Reason	Remedy
Green LED blinks 1 times, stops for 3s	E1	Not supported for this unit. If error presents, please contact technical support.		
Green LED blinks 2 times, stops for 3s	E2	Indoor coil sensor 2 failure	Ti2 sensor unplugged or damaged.	1. Check if Ti2 plug is connected or not. 2. Check if sensor's resistance is correct or not.
Green LED blinks 3 times, stops for 3s	E3	Return air sensor failure	Room sensor unplugged or damaged.	1. Check if Tr plug is connected or not. 2. Check if sensor's resistance is correct or not.
Green LED blinks 4 times, stops for 3s	E4	Indoor coil sensor 1 failure	Ti1 sensor unplugged or damaged.	1. Check if Ti1 plug is connected or not. 2. Check if sensor's resistance is correct or not.
Green LED blinks 5 times, stops for 3s	E5	Indoor coil low temperature protection	Water temperature is lower than 37.4°F .	Check the water temperature.
Green LED blinks 6 times, stops for 3s	E6	Indoor coil over heat protection	Water temperature is higher than 158°F .	Check the water temperature.
Green LED blinks 9 times, stops for 3s	E9	EC motor failure	No EC motor feedback	1. Check DIPB-SW5 and SW6 setting. 2. Check the EC motor.
Green LED blinks 11 times, stops for 3s	E11	Anti-frozen protection	When unit is standby, $Ti1 < 35.6^\circ\text{F}$	Turn on unit to keep $Ti1$ higher than 41°F .

E. Users Interface

Remote Control Handset

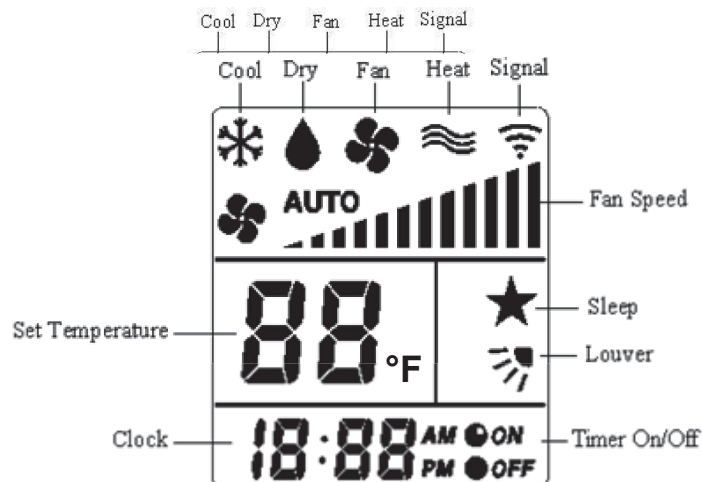
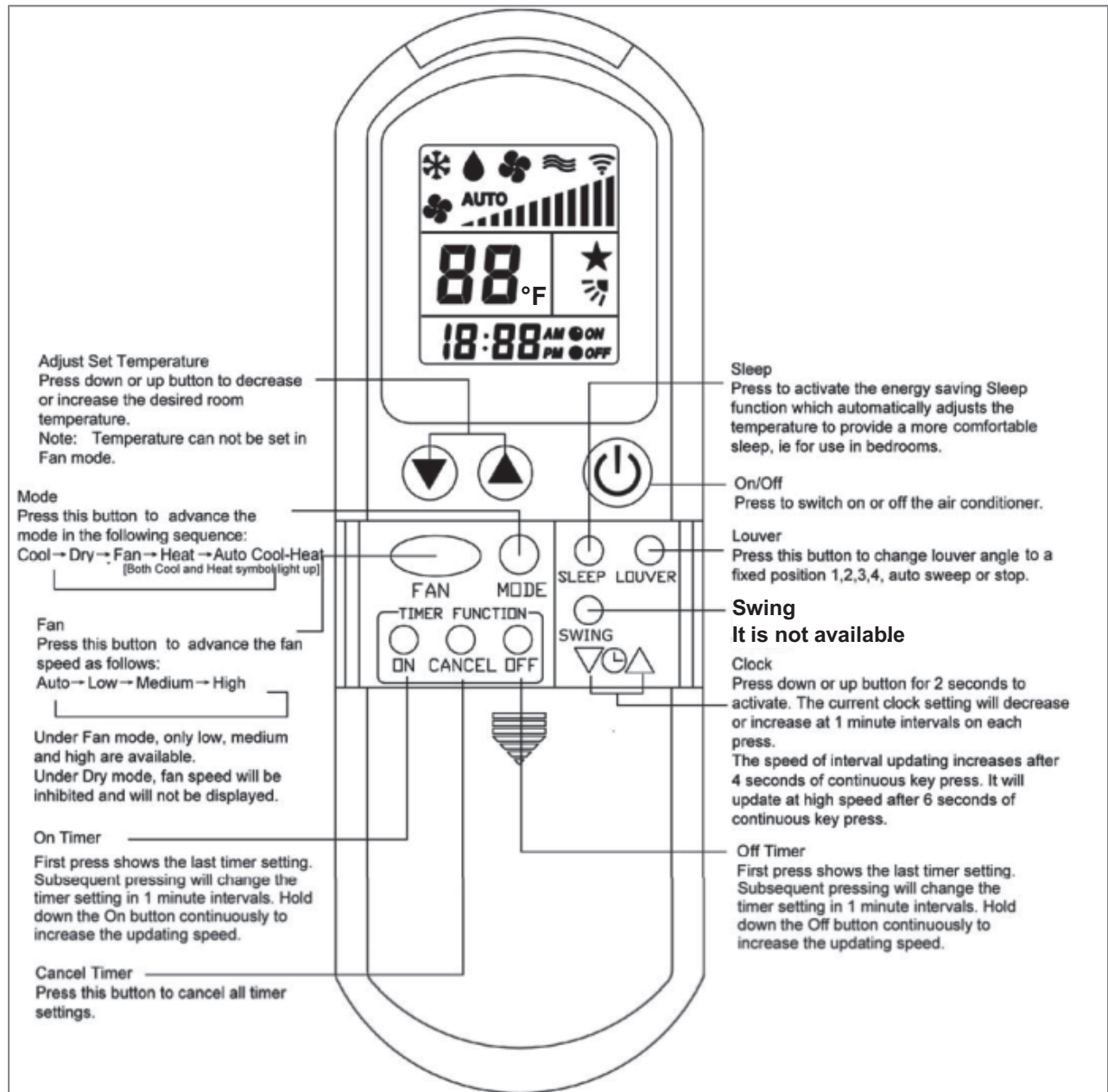

Attention

When unit with handset is the master unit, its settings are automatically sent to the slave units; Auto Cool-Heat operation will be applicable in 4-pipe system only.

“Swing” function is not applicable.
European version only uses degree C setting.

F. Sensor Resistance R-T Conversion Table

Resistance : R (77°F) = 10KΩ ± 1%

Beta Constant : B (25/85) = 3977 ± 1%

T (°F)	Rmin (KΩ)	Rnom (KΩ)	Rmax (KΩ)	T (°F)	Rmin (KΩ)	Rnom (KΩ)	Rmax (KΩ)
-22	174	182.7	191.8	39.2	26.11	26.9	27.71
-20.2	163.4	171.5	179.9	41	24.85	25.59	26.34
-18.4	153.6	161.1	168.9	42.8	23.65	24.35	25.05
-16.6	144.4	151.3	158.5	44.6	22.52	23.17	23.83
-14.8	135.8	142.2	148.9	46.4	21.45	22.06	22.68
-13	127.8	133.8	140	48.2	20.44	21.01	21.59
-11.2	120.3	125.8	131.6	50	19.48	20.02	20.55
-9.4	113.3	118.4	123.8	51.8	18.58	19.7	19.58
-7.6	106.7	111.5	116.5	53.6	17.71	18.18	18.65
-5.8	100.6	105.1	109.7	55.4	16.9	17.33	17.77
-4	94.9	99.03	103.3	57.2	16.12	16.53	16.94
-2.2	89.51	93.39	97.41	59	15.39	15.77	16.16
-0.4	84.5	88.11	91.85	60.8	14.69	15.05	15.41
1.4	79.8	83.17	86.64	62.6	14.03	14.37	14.7
3.2	75.39	78.53	81.76	64.4	13.41	13.72	14.03
5	71.26	74.18	77.19	66.2	12.81	13.1	13.4
6.8	67.37	70.1	72.9	68	12.24	12.52	12.79
8.6	63.73	66.26	68.88	69.8	11.7	11.96	12.22
10.4	60.3	62.67	65.1	71.6	11.19	11.43	11.67
12.2	57.08	59.28	61.55	73.4	10.71	10.93	11.15
14	54.05	56.1	58.22	75.2	10.24	10.45	10.66
15.8	51.19	53.12	55.08	77	9.8	10	10.2
17.6	48.51	50.3	52.14	78.8	9.374	9.57	9.765
19.4	45.98	47.66	49.37	80.6	8.969	9.16	9.351
21.2	43.61	45.17	46.77	82.4	8.584	8.77	8.957
23	41.36	42.82	44.31	84.2	8.218	8.4	8.582
24.8	39.25	40.61	42	86	7.869	8.047	8.225
26.6	37.26	38.53	39.83	87.8	7.537	7.71	7.885
28.4	35.38	36.56	37.78	89.6	7.221	7.39	7.56
30.2	33.6	34.71	35.85	91.4	6.92	7.085	7.251
32	31.93	32.97	34.02	93.2	6.633	6.794	6.956
33.8	30.35	31.32	32.3	95	6.36	6.517	6.675
35.6	28.85	29.76	30.68	96.8	6.099	6.252	6.407
37.4	27.44	28.29	29.15	98.6	5.85	6	6.151

Resistance : R (77°F) = 10KΩ ± 1%
 Beta Constant : B (25/85) = 3977 ± 1%

T (°F)	Rmin (KΩ)	Rnom (KΩ)	Rmax (KΩ)	T (°F)	Rmin (KΩ)	Rnom (KΩ)	Rmax (KΩ)
100.4	5.614	5.759	5.907	167	1.417	1.474	1.532
102.2	5.387	5.53	5.673	168.8	1.37	1.426	1.482
104	5.172	5.31	5.451	170.6	1.326	1.379	1.434
105.8	4.966	5.101	5.238	172.4	1.282	1.335	1.389
107.6	4.769	4.901	5.034	174.2	1.241	1.292	1.344
109.4	4.582	4.71	4.84	176	1.201	1.25	1.302
111.2	4.402	4.527	4.654	177.8	1.162	1.211	1.261
113	4.231	4.353	4.477	179.6	1.125	1.172	1.221
114.8	4.067	4.186	4.307	181.4	1.089	1.135	1.183
116.6	3.911	4.027	4.144	183.2	1.055	1.1	1.146
118.4	3.761	3.874	3.989	185	1.021	1.065	1.111
120.2	3.618	3.728	3.84	186.8	0.9891	1.032	1.077
122	3.481	3.588	3.697	188.6	0.9582	1	1.044
123.8	3.35	3.454	3.561	190.4	0.9284	0.9697	1.012
125.6	3.225	3.326	3.43	192.2	0.8998	0.9401	0.9818
127.4	3.105	3.204	3.305	194	0.8721	0.9115	0.9522
129.2	2.99	3.086	3.185	195.8	0.8455	0.8839	0.9237
131	2.88	2.974	3.07	197.6	0.8198	0.8573	0.8961
132.8	2.774	2.866	2.959	199.4	0.795	0.8316	0.8696
134.6	2.673	2.762	2.854	201.2	0.7711	0.8069	0.8439
136.4	2.576	2.663	2.752	203	0.748	0.783	0.8192
138.2	2.483	2.568	2.655	204.8	0.7258	0.7599	0.7953
140	2.394	2.477	2.562	206.6	0.7043	0.7376	0.7722
141.8	2.309	2.39	2.472	208.4	0.6836	0.7161	0.7499
143.6	2.227	2.306	2.386	210.2	0.6635	0.6953	0.7283
145.4	2.149	2.225	2.304	212	0.6442	0.6752	0.7075
147.2	2.073	2.148	2.224	213.8	0.6255	0.6558	0.6874
149	2.001	2.074	2.148	215.6	0.6075	0.6371	0.6679
150.8	1.931	2.002	2.075	217.4	0.59	0.619	0.6491
152.6	1.865	1.934	2.005	219.2	0.5732	0.6015	0.631
154.4	1.801	1.868	1.937	221	0.5569	0.5846	0.6134
156.2	1.739	1.805	1.872				
158	1.68	1.744	1.81				
159.8	1.623	1.686	1.75				
161.6	1.569	1.63	1.692				
163.4	1.516	1.576	1.637				
165.2	1.466	1.524	1.583				

G. Troubleshooting Guide

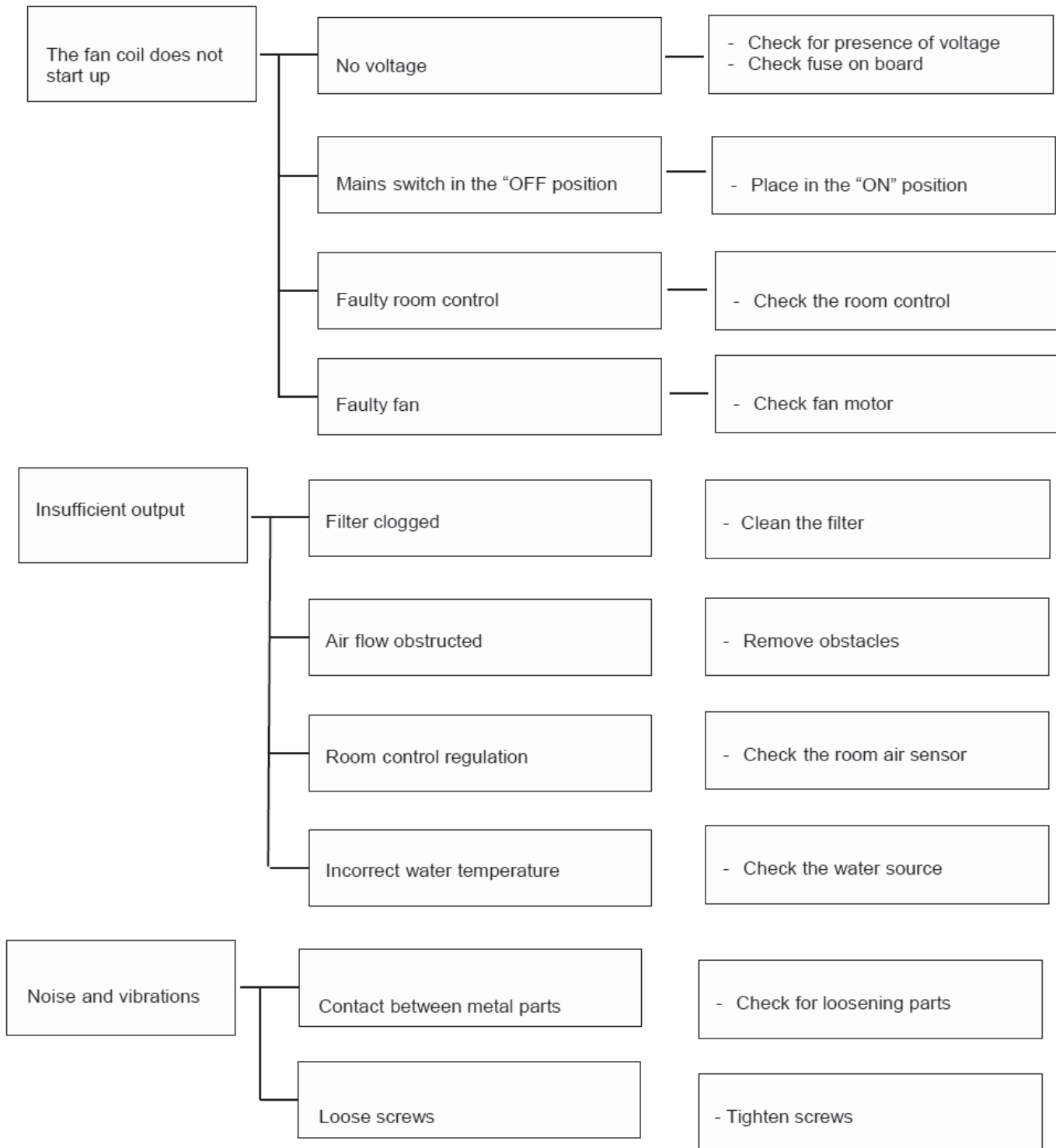

H. Replacement Parts

Order Code	Description	HW-06	HW-15	HW-18
45W37-WG1118-01	Front Lift Up Cover (access filters)	X	X	X
45W27-WG1119-01	Air Inlet Filter	X	X	X
45W37-WG1120-01	Front Casing	X	X	X
45W37-WG1121-01	Power Input Cover	X	X	X
45W21-WG1122-01	Screw Cover	X	X	X
45W37-WG1123-01	Rear Casing	X	X	X
45W40-WG1124-01	Pipe Clamp	X	X	X
45W31-WG1125-01	EC Motor	X	X	X
45W37-WG1126-01	Motor Cover	X	X	X
45W34-WG1127-01	Fan Blower	X	X	X
45W42-WG1128-01	Fan Bearing	X	X	X
45W06-WG1129-01	Condensate Pan	X	X	X
45W06-WG1130-01	Drain Plug	X	X	X
45W37-WG1131-01	Swing Louver Collar	X	X	X
45W37-WG1132-01	Vertical Louver	X	X	X
45W45-WG1133-01	Connecting Rod	X	X	X
45W45-WG1134-01	Swing Louver Crank #1	X	X	X
45W45-WG1135-01	Swing Louver Crank #2	X	X	X
45W45-WG1136-01	Crank Connection Rod	X	X	X
45W37-WG1137-01	Crank Cover	X	X	X
45W31-WG1138-01	Louver Motor	X	X	X
45W37-WG1139-01	Upper Swing Louver	X	X	X
45W37-WG1140-01	Lower Swing Louver	X	X	X
45W41-WG1141-01	Condensate Drain Hose	X	X	X
45W43-WG1142-01	Wall Mounting Plate	X	X	X
45W09-WG1143-01	Return Air Sensor	X	X	X
45W09-WG1144-01	Chilled Water Sensor	X	X	X
45W09-WG1145-01	Hot Water Sensor	X	X	X
45W06-WG1146-01	LED Mount	X	X	X
45W37-WG1147-01	LED Cover	X	X	X
45W09-WG1148-01	IR Receiver	X	X	X
45W43-WG1149-01	Terminal Block	X	X	X
45W20-WG1150-01	Wire Retention Clip	X	X	X
45W37-WG1151-01	Left Coil Bracket	X	X	X
45W50-WG1152-01	Hydronic Coil	X		
45W50-WG1153-01	Hydronic Coil		X	
45W28-WG1154-01	22" Water Hose	X	X	X
45W50-WG1156-01	Hydronic Coil			X
45W11-WG1171-01	Control Board Assembly	X	X	X



IN UNITED STATES: 260 NORTH ELM ST. WESTFIELD, MA 01085 800-465-8558 / FAX (413) 564-5815
IN CANADA: 7555 TRANMERE DRIVE, MISSISSAUGA, ONTARIO, L5S 1L4 (905) 670-5888 / FAX (905) 670-5782