

**OIL RESERVE OIL SEPARATORS**  
(Models OS-15, OS-25, OS-35, OS-50, OS-75, OS-100, and OS-500)



# WARNING



**DO NOT AIR PRESSURE TEST UNIT!**  
**DOING SO MAY RESULT IN PROPERTY DAMAGE, SERIOUS BODILY INJURY, OR DEATH!**  
**REFER TO INSTALLATION INSTRUCTIONS FOR CORRECT TESTING PROCEDURE.**

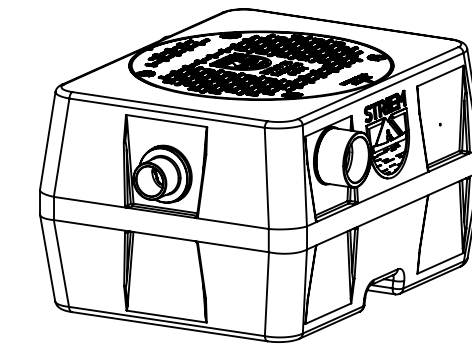

**OS-15**  
15 gpm, 15 gallons  
10 gallon oil capacity  
1 gallon sand capacity

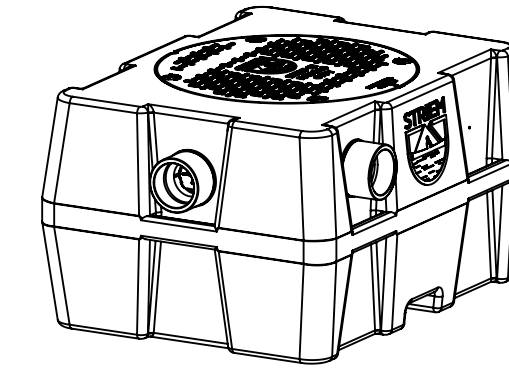

**OS-25**  
25 gpm, 21 gallons  
15 gallon oil capacity  
6 gallon sand capacity

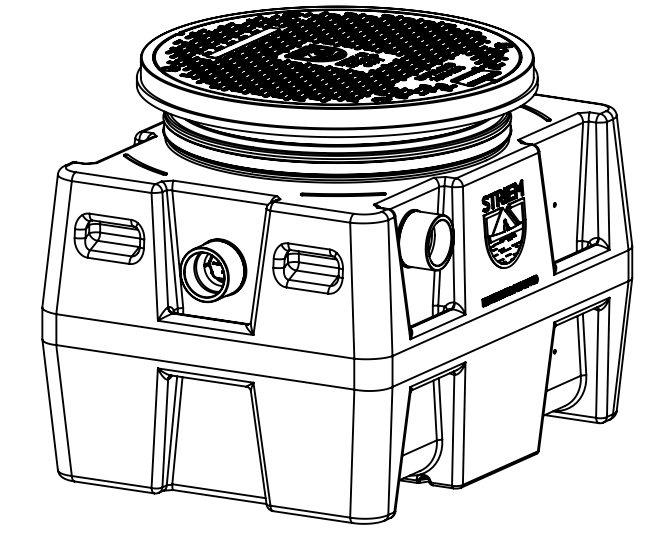

**OS-35**  
35 gpm, 38 gallons  
28 gallon oil capacity  
6 gallon sand capacity

**Sheet Descriptions**

- Sheet #1 - Series overview and Warranty information
- Sheet #2 - OS General installation guidelines and Operation/Maintenance guidelines
- Sheet #3 - Below Grade installation guidelines
- Sheet #4 - Below and Above Grade installation guidelines
- Sheet #5 - Multiple unit systems. Setting the oil draw off
- Sheet #6 - OCT General installation guidelines and Operation/Maintenance guidelines
- Sheet #7 - TeleGlide Riser installation guidelines (SR24, LR24)
- Sheet #8 - TeleGlide Riser installation guidelines (SR16)

**Leak/Seal Testing**

**DO NOT AIR TEST UNIT OR TELEGLIDE RISER SYSTEM! Doing so may result in property damage, personal injury or death.**

**Base Unit:** To perform a leak/seal test on the base unit, cap/plug all plumbing connections, remove the cover, and fill the unit with water just above the highest connection. Inspect unit and connections for leaks. Check water level at specific time intervals per local code.

**TeleGlide Riser System:** If required by local code, the riser system may be leak/seal tested similar to the base unit. **CAUTION:** the riser(s) must be supported before filling with water to keep from tipping over. Once riser system is in place and properly supported, cap/plug all plumbing connections on the main unit, remove the cover from the top of the riser assembly and fill the unit and riser system with water to finished grade level. Carefully, as the riser(s) will be very heavy from the weight of the water, inspect all gasket(s) and clamps (if applicable) for any leaks. Check water level at specific time intervals per local code.

**Lifetime Warranty**

Effective March 2, 2015 Striem represents and warrants that HDPE and PP products will be free from any and all defects in material and workmanship, including corrosion, during the lifetime of the plumbing system in which the Products were originally installed and will, at its option, agree to repair, replace, or supply credit to the original purchaser.

This warranty does not cover damage caused by the Products' normal usage, or wear and tear, nor does it cover damage from naturally occurring phenomenon, including, but not limited to UV, freeze-related damage, or natural disasters. This warranty does not cover the purchaser's cost of routine maintenance including replacement of parts required in routine maintenance.

This warranty does not cover fabricated steel products, or any monitoring equipment. This warranty shall be effective if, and only if, the Products:

- \* Were installed in accordance with Striem's notes, specifications and instructions, for installation, operation, and maintenance;
- \* Were installed in conformance with all applicable building and plumbing codes, and passed all applicable testing methods immediately following installation;
- \* Have not been subjected to misuse or abuse, whether negligent or intentional;
- \* Were never modified, repaired, or altered by any individual(s) not authorized by Striem.

This warranty is the purchaser's sole and exclusive remedy, and acceptance of this exclusive remedy is a condition of the contract for the purchase of these Products. In no event shall Striem be liable for any incidental, special, consequential or punitive damages, or for any costs, attorney fees, expenses, losses or delays claimed to be as a consequence of any damage to, failure of, or defect in any products including, but not limited to, any claims for loss of profits, transportation, removal and installation charges. This warranty is exclusive and in lieu of all other warranties or conditions, written or oral, expressed or implied.

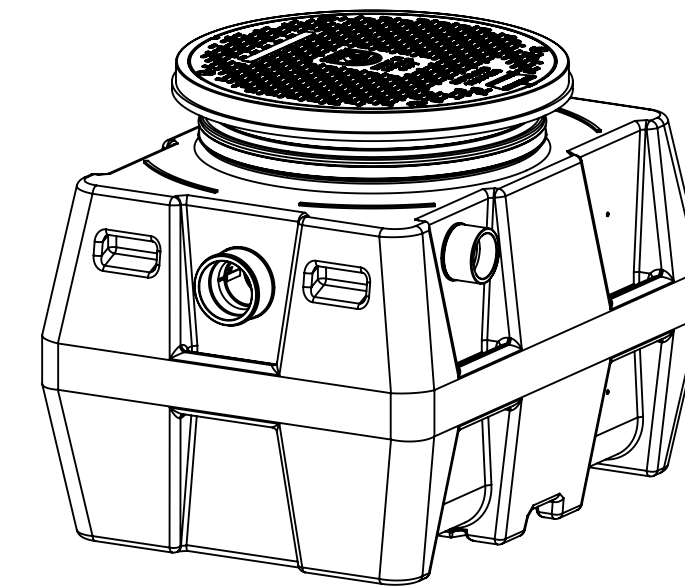

**OS-50**  
50 gpm, 57 gallons  
40 gallon oil capacity  
7 gallon sand capacity

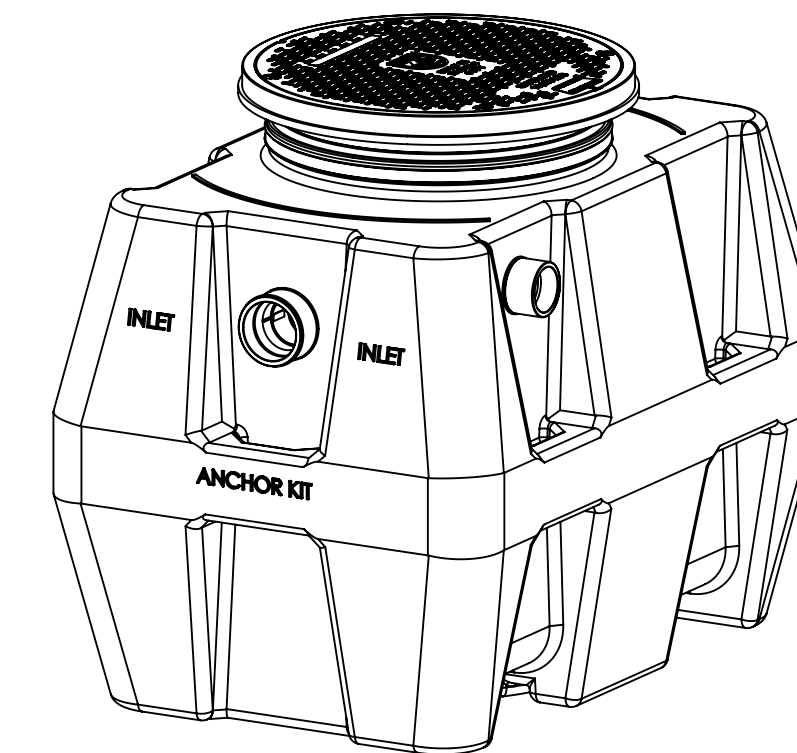

**OS-75**  
75 gpm, 110 gallons  
93 gallon oil capacity  
11 gallon sand capacity



**OS-100**  
100 gpm, 250 gallons  
144 gallon oil capacity  
95 gallon sand capacity

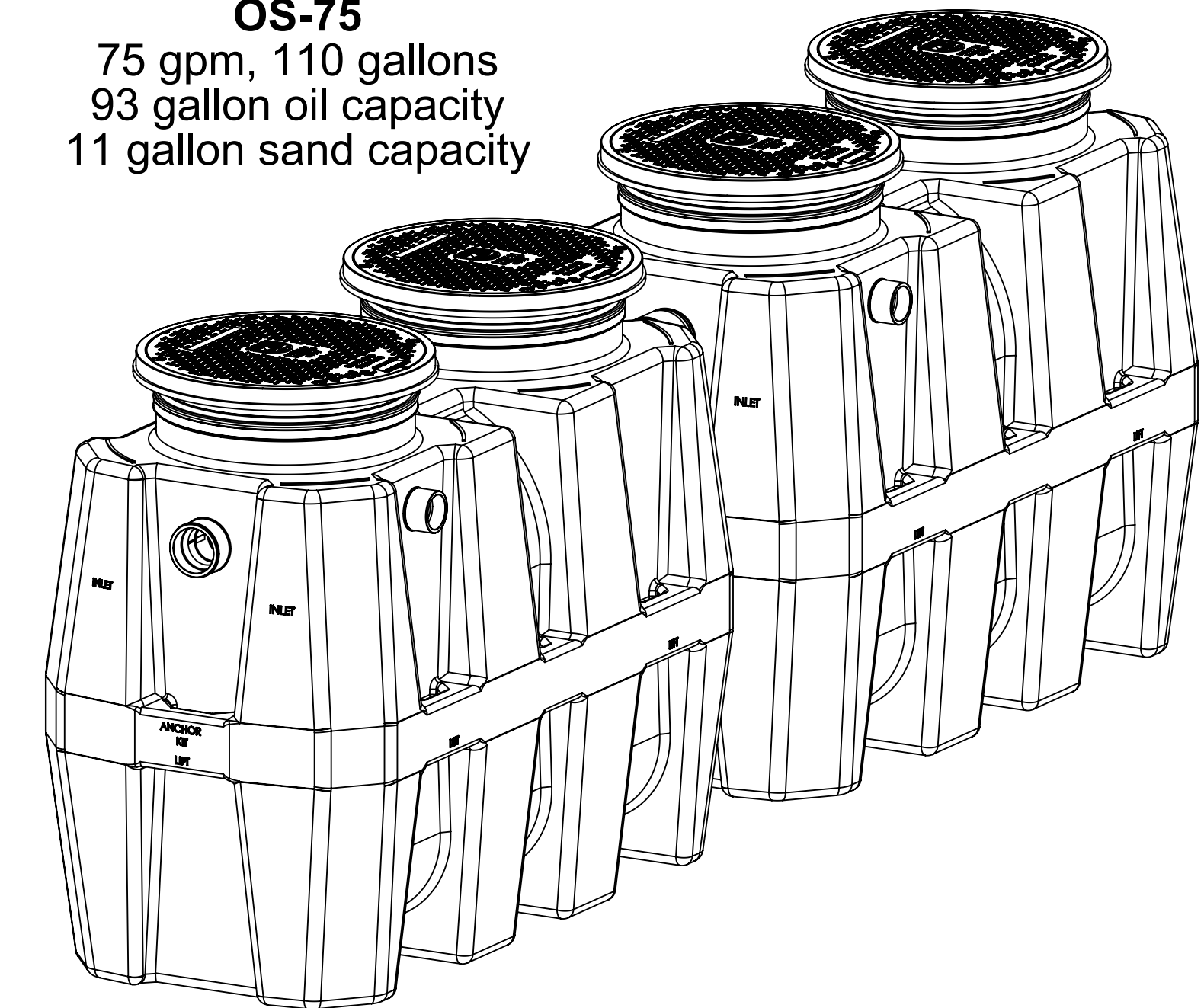

**OS-500**  
100 gpm, 500 gallons  
288 gallon oil capacity  
95 gallon sand capacity

**NOTES:**

Striem oil separators are rated and manufactured with an internal flow control system already in place. They do not require an external flow control system or air intake vent.

Striem oil separators are not to be installed in any other manner except as shown. Consult local codes for separate trapping requirements, cleanout locations and additional installation instructions.

PROPRIETARY AND CONFIDENTIAL  
THE INFORMATION CONTAINED IN THIS DRAWING IS THE SOLE PROPERTY OF STRIEM, LLC.  
ANY REPRODUCTION IN PART OR AS A WHOLE WITHOUT THE WRITTEN PERMISSION OF STRIEM, LLC. IS PROHIBITED.

<b>DESCRIPTION:</b>			
<b>OS &amp; OCT SERIES INSTALLATION, OPERATION AND MAINTENANCE GUIDE</b>			
<b>SHEET NUMBER:</b> 1 of 7			
<b>DWG BY:</b> MJ	<b>DATE:</b> 8/15/18	<b>REV:</b>	<b>ECO:</b>

**Striem**  
3100 Brinkerhoff  
Kansas City, KS 66115  
Tel: 913-222-1500  
Fax: 913-291-0457  
www.striemco.com

Made in the U.S.A



## GENERAL SEPARATOR INSTALLATION INSTRUCTIONS (OS-100 SHOWN)

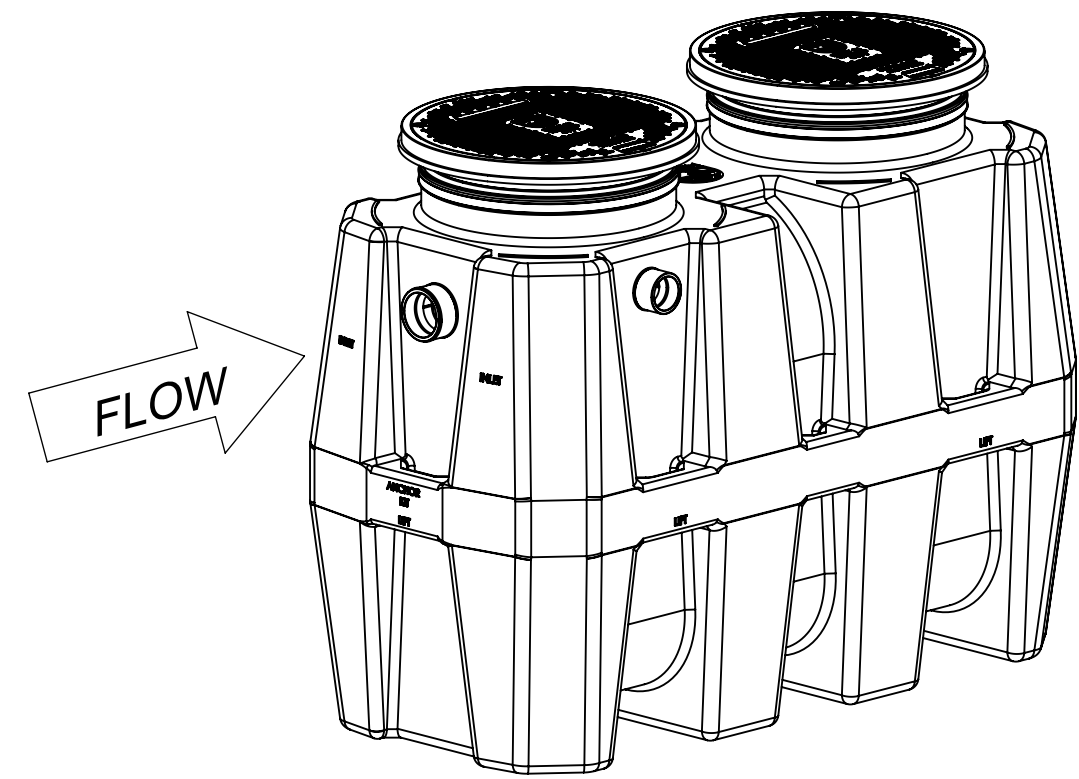

Isometric View

Set unit on level solid surface as close as possible to fixtures being served. If unit is to be installed below grade refer to below grade installation instructions. (sheet #3)

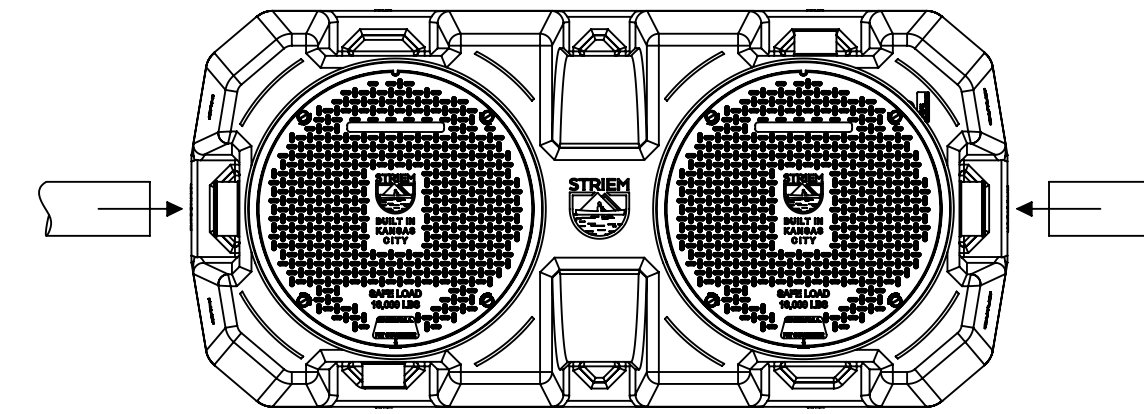

Top View

Connect inlet and outlet drainage lines to unit. Mechanically couple pipes to unit. **Do not solvent weld.** If connecting multiple units for an engineered oil separator system refer to multiple unit installation sheet. (sheet #5)

### OPERATION

Striem Oil Separators are engineered to separate oil and other lighter-than-water contaminants from wastewater to keep them from entering the sewage system. This is accomplished using Striem's patented Diffusion Flow design. The inlet diffuser distributes the wastewater through the separator in a smooth, even flow pattern which eliminates dead spots. This diffused flow assures that the oil and sediment layers are undisturbed and increases the efficiency of the separator.

### MAINTENANCE

1. For most thorough cleaning contact a professional pumper contractor.
2. Wear appropriate safety equipment when cleaning. Do not smoke near separator or clean near open flame or sparks.
3. Remove cover(s).
4. Remove coalescing media (if applicable) and thoroughly wash down into appropriate container.
5. Remove all contents of the separator including oil, sediment and wastewater.
6. To access the inlet and outlet lines for cleaning as needed:
  - a.) 4" connections: Remove the inlet and outlet diffusers (inside unit(s)) by hand loosening green locking collars.
  - b.) 6" connections: Remove threaded clean-out plug from the back of the inlet and outlet diffusers.
7. Clean the drain lines, diffusers and air relief thoroughly of all debris before replacing diffusers to original positions or reinstalling threaded clean-out plug.
8. Fill unit(s) with water.
9. Inspect gasket for wear and tear. Replace cover(s).
10. Dispose of oil per local code.

### PUMPING FREQUENCY:

Frequency depends on the capacity of the separator and the amount of oil and sediment in the wastewater.

After initial installation, it is recommended that the unit is fully pumped every 3 to 4 weeks. Monitor each pumping to establish an adequate maintenance schedule Striem Products recommends pumping frequency to exceed no more than 6 months.

### TROUBLESHOOTING TIPS:

In the case of a clog, inlet and outlet diffusers may be removed for line cleaning. Slower than usual drainage may indicate the need to pump/clean oil separator. Units with 6" connections have a removable plug on the back of the diffuser as the diffuser itself is not removable.

Always take proper care to ensure a safe and healthy environment while cleaning separator. For best cleaning and maintenance service, call your local sewer and drain contractor.

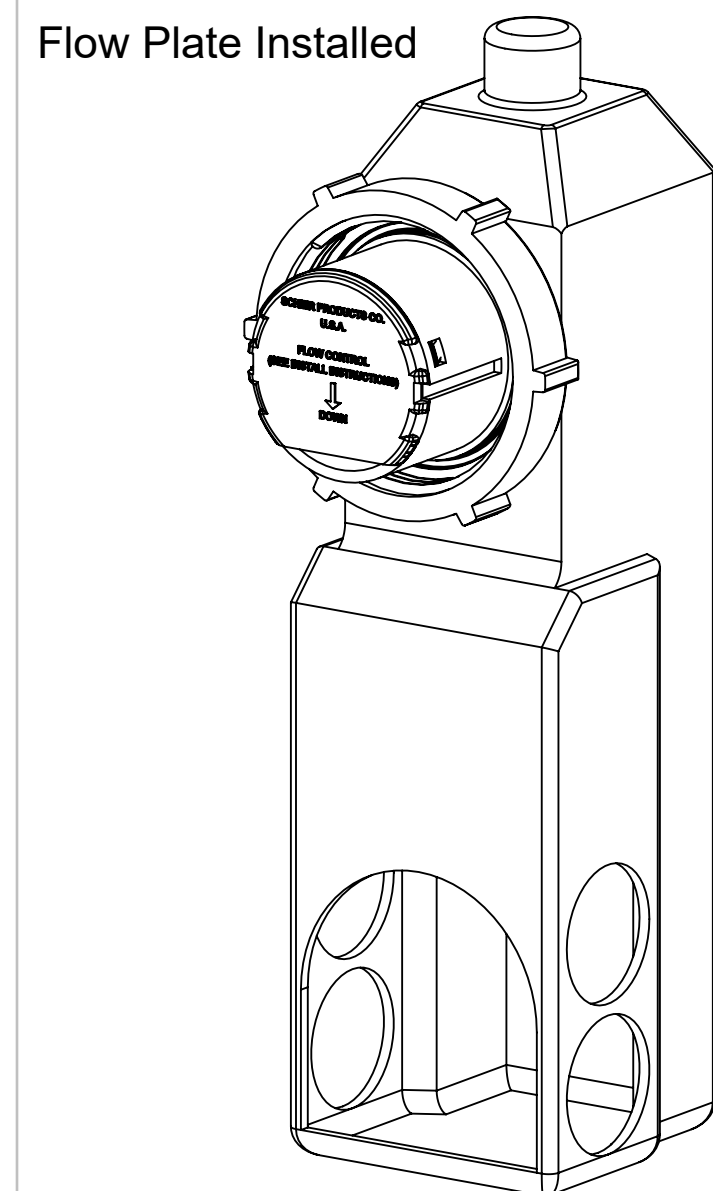

Flow Plate Installed

To maintain proper flow rate, when interceptor is installed in a high flow or increased head pressure application keep calibrated flow plate installed. Flow plate calibrated to rated GPM at 13 foot water column.

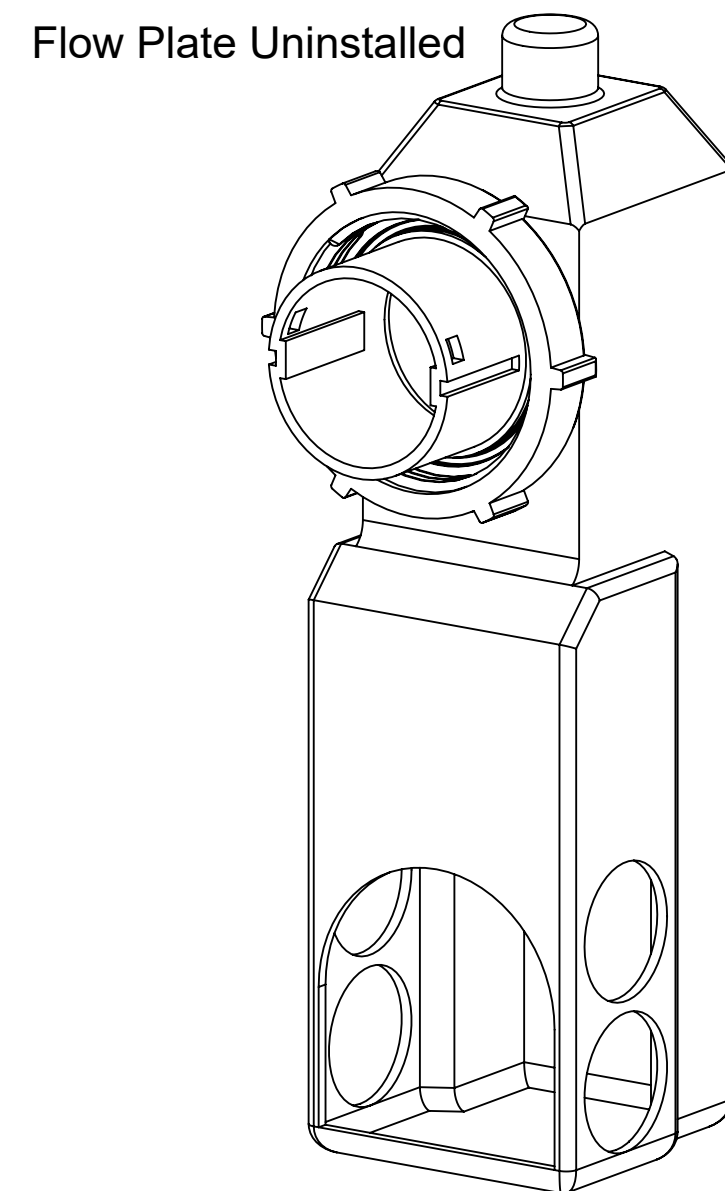

Flow Plate Uninstalled

To maintain proper flow rate, when interceptor is installed in a low flow or reduced head pressure application remove and discard calibrated flow plate.

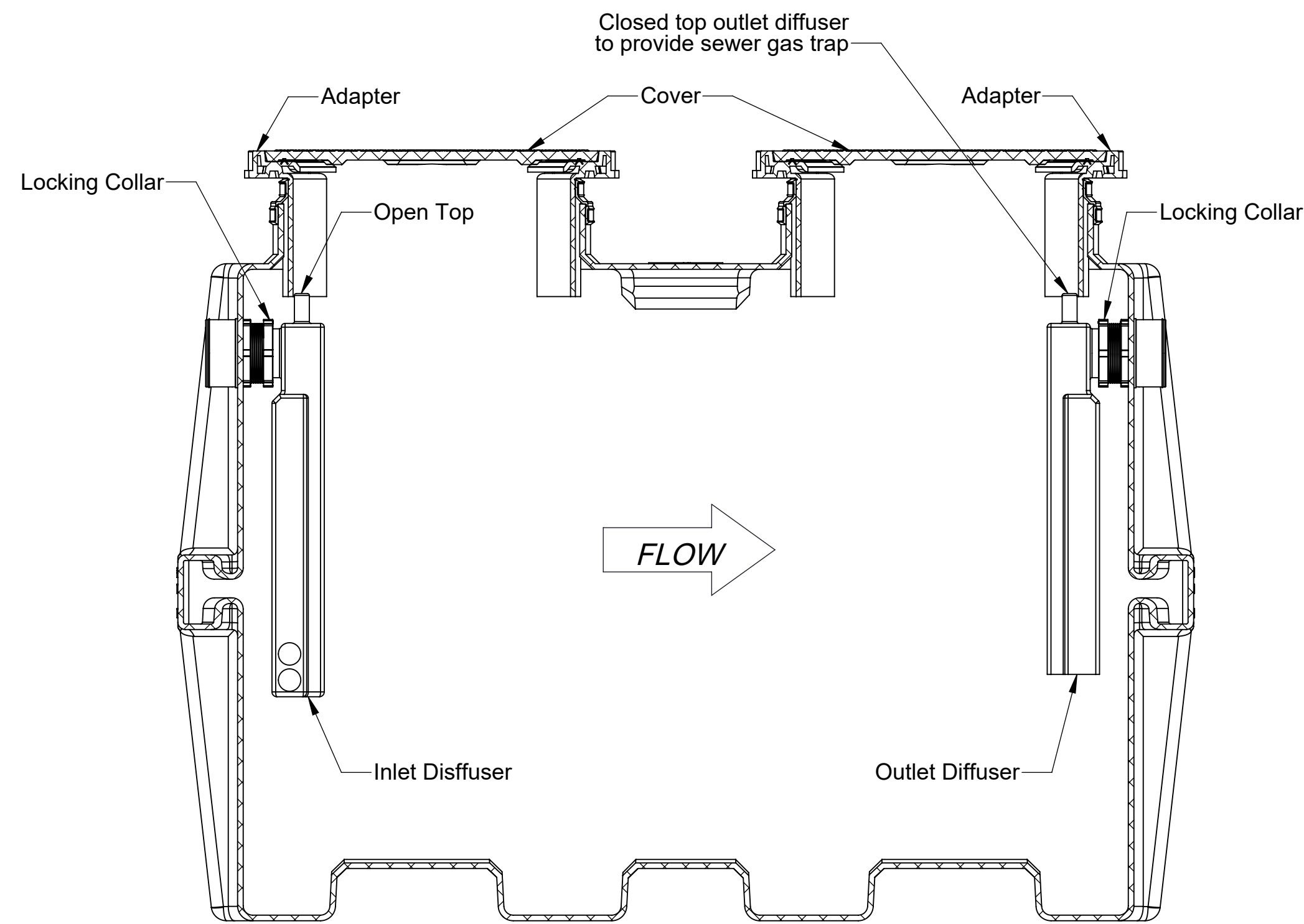

OS-100 SHOWN

### NOTES:

Striem oil separators are rated and manufactured with an internal flow control system already in place. They do not require an external flow control system or air intake vent.

Striem oil separators are not to be installed in any other manner except as shown. Consult local codes for separate trapping requirements, cleanout locations and additional installation instructions.

#### DESCRIPTION:

OS & OCT SERIES INSTALLATION,  
OPERATION AND MAINTENANCE GUIDE

SHEET NUMBER: 2 of 7

DWG BY: MJ    DATE: 8/15/18    REV:    ECO:

**Striem**  
3100 Brinkerhoff  
Kansas City, KS 66115  
Tel: 913-222-1500  
Fax: 913-291-0457  
www.striemco.com

Made in the U.S.A



PROPRIETARY AND CONFIDENTIAL  
THE INFORMATION CONTAINED IN THIS DRAWING IS THE SOLE PROPERTY OF STRIEM, LLC. ANY REPRODUCTION IN PART OR AS A WHOLE WITHOUT THE WRITTEN PERMISSION OF STRIEM, LLC IS PROHIBITED.

# INTERIOR OR EXTERIOR BELOW GRADE INSTALLATION INSTRUCTIONS (OS-35, OS-50, OS-75, OS-100, OS-500)

## BELOW GRADE INSTALLATION INSTRUCTIONS

### EXCAVATION

1. Install unit(s) as close as possible to fixtures being serviced.
2. Width and length of excavation shall be minimum 12" greater than the tank on all sides.
3. Depth of excavation shall be 6" deeper than tank bottom.
4. Set the tank in well-packed crushed aggregate material approximately 3/4" size rock, or sand, with no fines. When setting OS-75 (2) and the OS-500 all units must be level.
5. Anchor kit is recommended for installations in high water table conditions to prevent float out. To be determined by specifying engineer. If necessary, order optional "Anchor Kit". See detail on this sheet.

### BACKFILLING & FINISHED CONCRETE SLAB

1. Preparation of sub grade per geotech recommendations.
2. Stabilize and compact sub grade to 95% proctor.
3. Fill tank with water before backfilling to prevent float out during piping installation.
4. Before backfilling and pouring of slab secure cover(s) and riser/s (if necessary) to the unit(s)
5. Backfill using crushed aggregate material approximately 3/4" size rock, or sand, with no fines.
6. Place 6" aggregate base under slab. Aggregate should be 3/4" size rock, or sand, with no fines.
7. Thickness of concrete around cover to be determined by specifying engineer. If traffic loading is required the concrete slab dimensions shown are for guideline purposes only.
8. Concrete to be 28 day compressive strength to 4000 PSI.
9. NO. 4 rebar ( $\phi$  1/2") grade 60 steel per ASTM A615: connected with tie wire.
10. Rebar to be 2 1/2" from edge of concrete.
11. Rebar spacing 12" grid. 4" spacing around access openings.
12. All pipe penetrations to be sleeved or have slip connections.

### CONNECTIONS

Connect waste piping to the unit. When connecting OS-75 (2), and OS-500, install units in series, not parallel.  
Connect vent piping to vent connection on sidewall of tank per local code.

## ANCHOR KIT INSTALLATION DETAIL

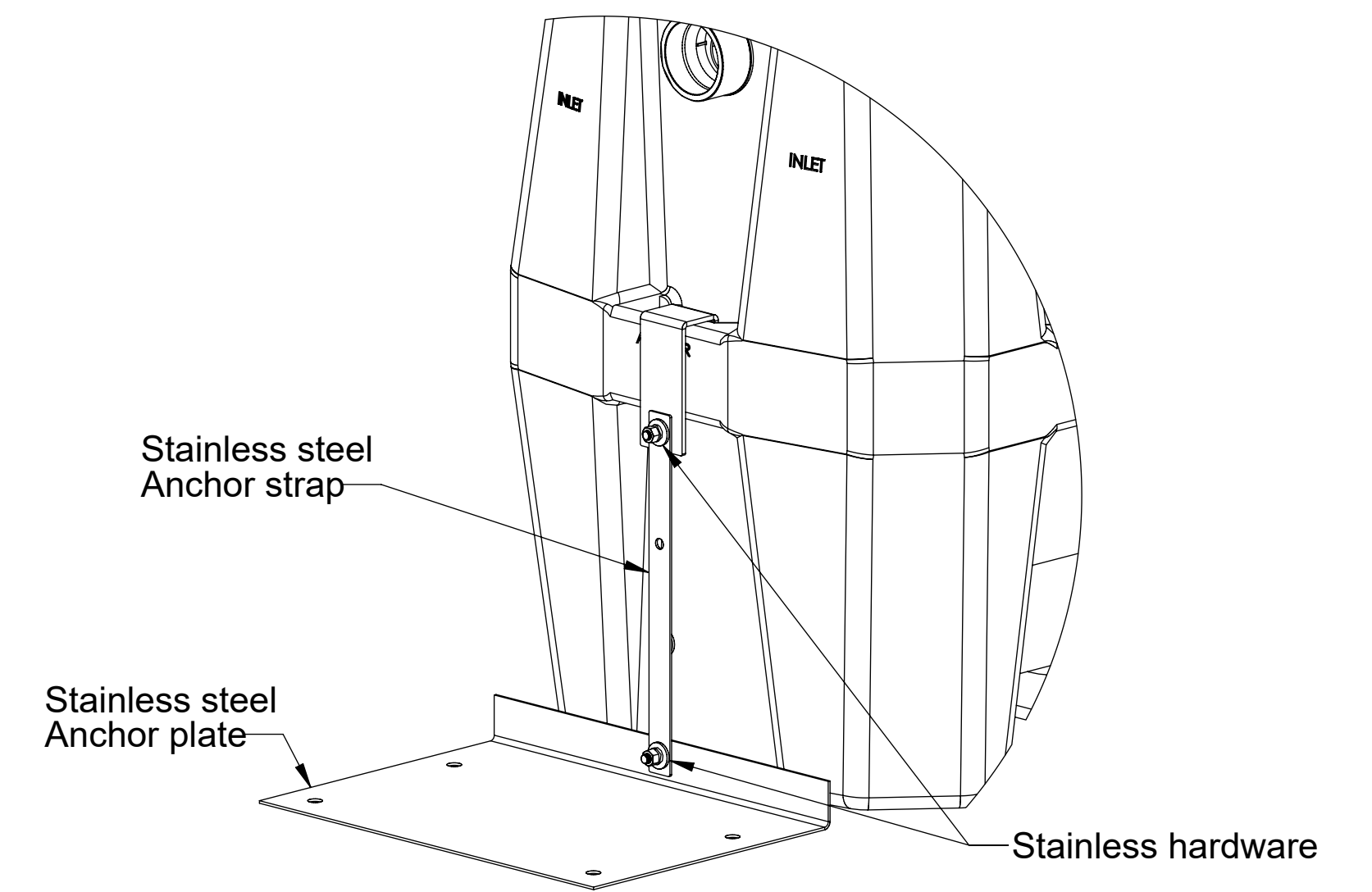

### Anchor Kit Installation Steps

1. Slide "Anchor Strap" over tie down point on end wall and bolt together using provided hardware.
2. Bolt "Anchor Strap" to "Anchor Plate" using provided hardware.
3. Hold down force achieved by backfill weight acting on Anchor Plate.
4. Anchor Plate may be bolted to concrete slab, if required, by using holes provided in Anchor Plate.

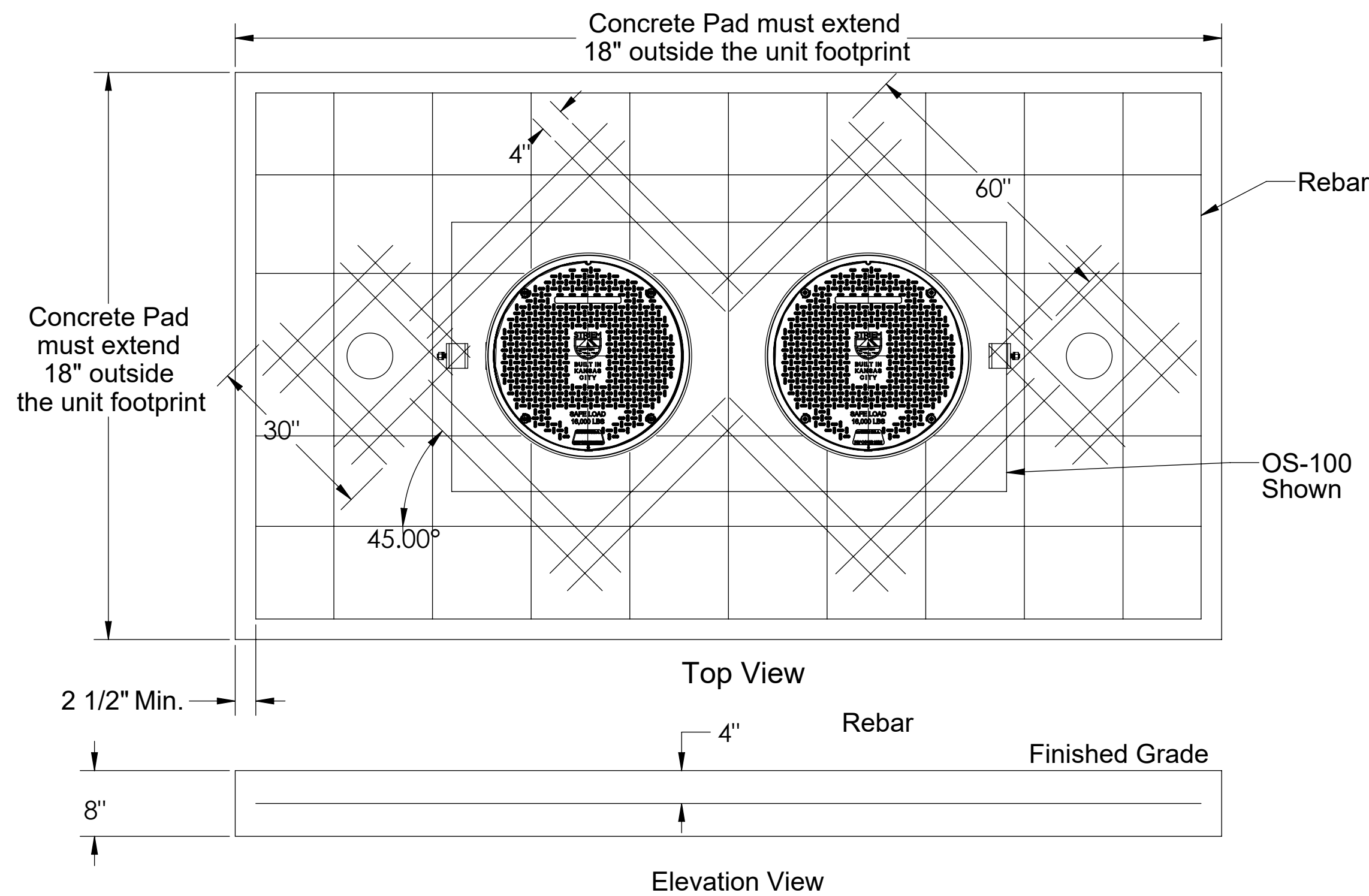

**CONCRETE SLAB DETAIL FOR TRAFFIC LOADING  
(INTERIOR OR EXTERIOR)  
(OS-100 Shown)**

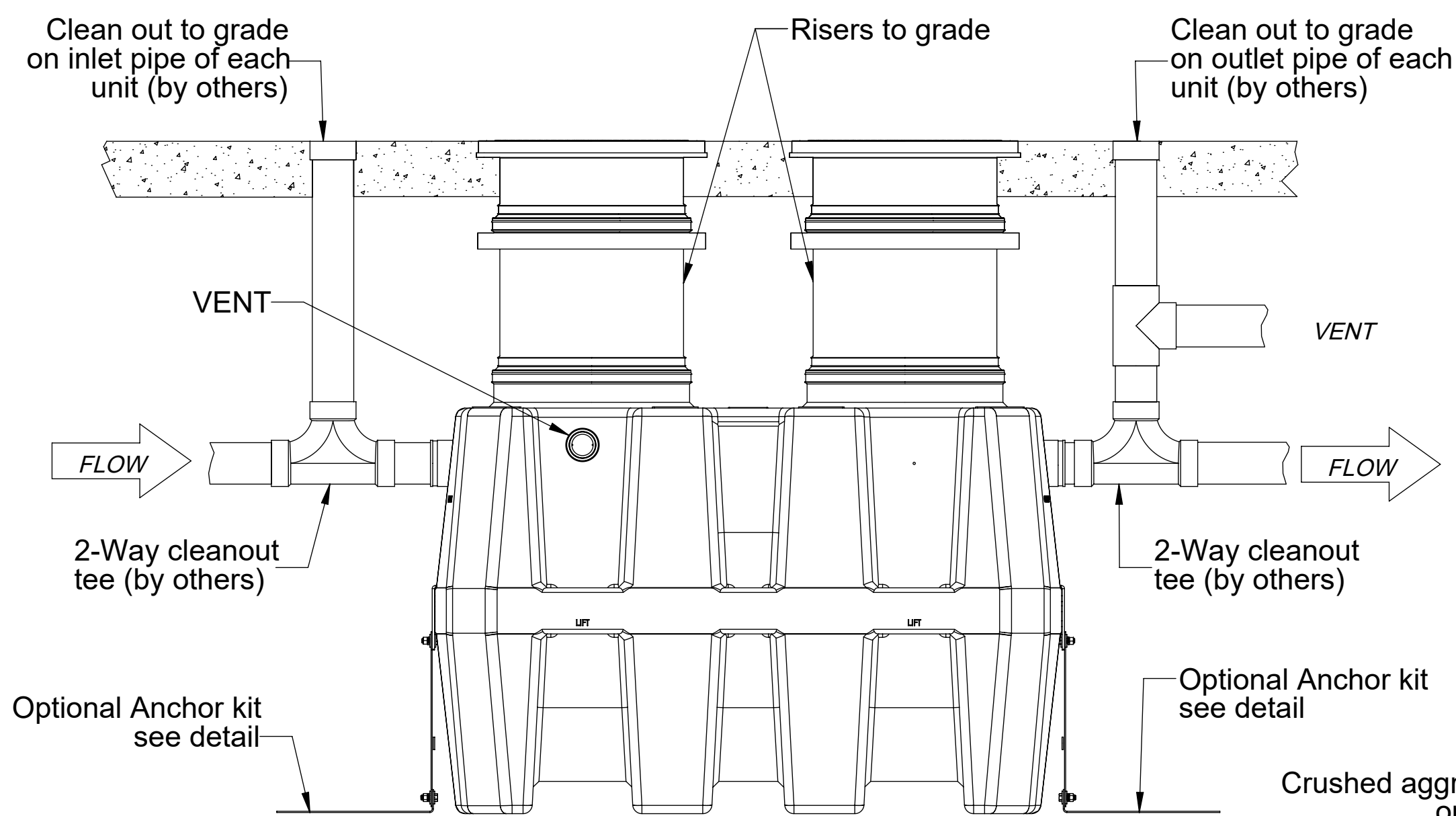

**SIDE VIEW DETAIL**

For unit details see specification sheet for selected unit  
(Connecting pipe and fittings by others)

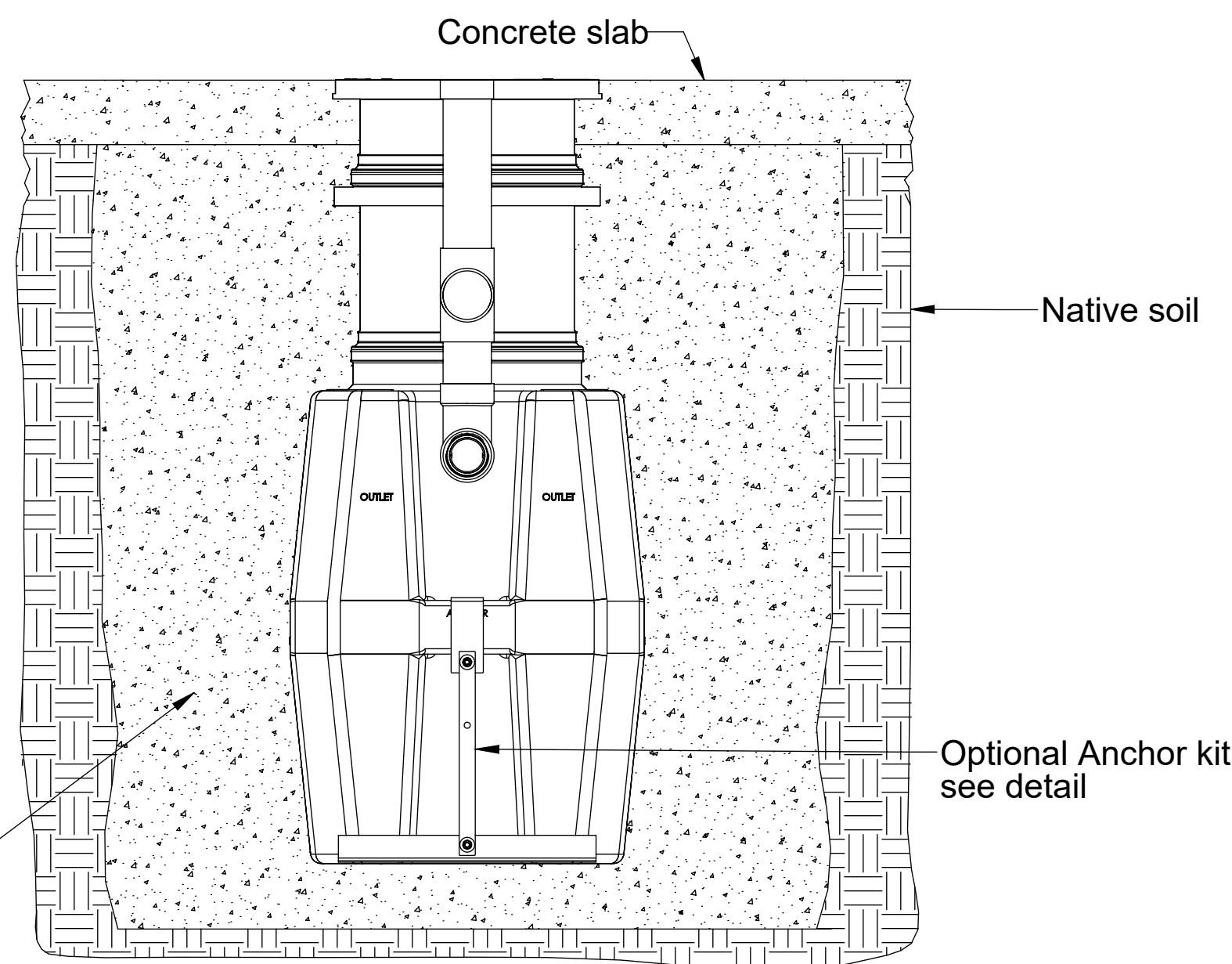

**EXCAVATION AND BACKFILL DETAIL  
(INTERIOR OR EXTERIOR)**

### NOTES:

Striem oil separators are rated and manufactured with an internal flow control system already in place. They do not require an external flow control system or air intake vent.

Striem oil separators are not to be installed in any other manner except as shown. Consult local codes for separate trapping requirements, cleanout locations and additional installation instructions.

### DESCRIPTION:

OS & OCT SERIES INSTALLATION,  
OPERATION AND MAINTENANCE GUIDE

SHEET NUMBER: 3 of 7

DWG BY: MJ    DATE: 8/15/18    REV:    ECO:

**Striem**  
3100 Brinkerhoff  
Kansas City, KS 66115  
Tel: 913-222-1500  
Fax: 913-291-0457  
www.striemco.com

Made in the U.S.A



PROPRIETARY AND CONFIDENTIAL  
THE INFORMATION CONTAINED IN THIS DRAWING IS THE SOLE PROPERTY OF STRIEM, LLC.  
ANY REPRODUCTION IN PART OR AS A WHOLE WITHOUT THE WRITTEN PERMISSION OF STRIEM, LLC, IS  
PROHIBITED.

## INTERIOR BELOW GRADE INSTALLATION INSTRUCTIONS (OS-15, OS-25)

### EXCAVATION

1. Install unit(s) as close as possible to fixtures being serviced.
2. Width and length of excavation shall be minimum 6" greater than the tank on all sides.
3. Depth of excavation shall be 6" deeper than tank bottom.
4. Set the tank in well-packed crushed aggregate #7 backfill material approximately 3/4" size rock, or sand, with no fines.

### CONNECTIONS

1. Connect waste piping to the unit.

### SET OIL DRAW OFF

1. If unit is ordered with optional oil draw off connection, see sheet 5 for correct settings.

### BACKFILLING & FINISHED CONCRETE SLAB

1. Before backfilling and pouring of slab secure cover(s) to the unit(s).
2. Backfill using crushed aggregate #7 backfill material approximately 3/4" size rock or sand with no fines.
3. Place 6" aggregate base under slab.

### Note

Models OS-15 and OS-25 cannot be installed flush with floor. A riser must be used for below grade installations.

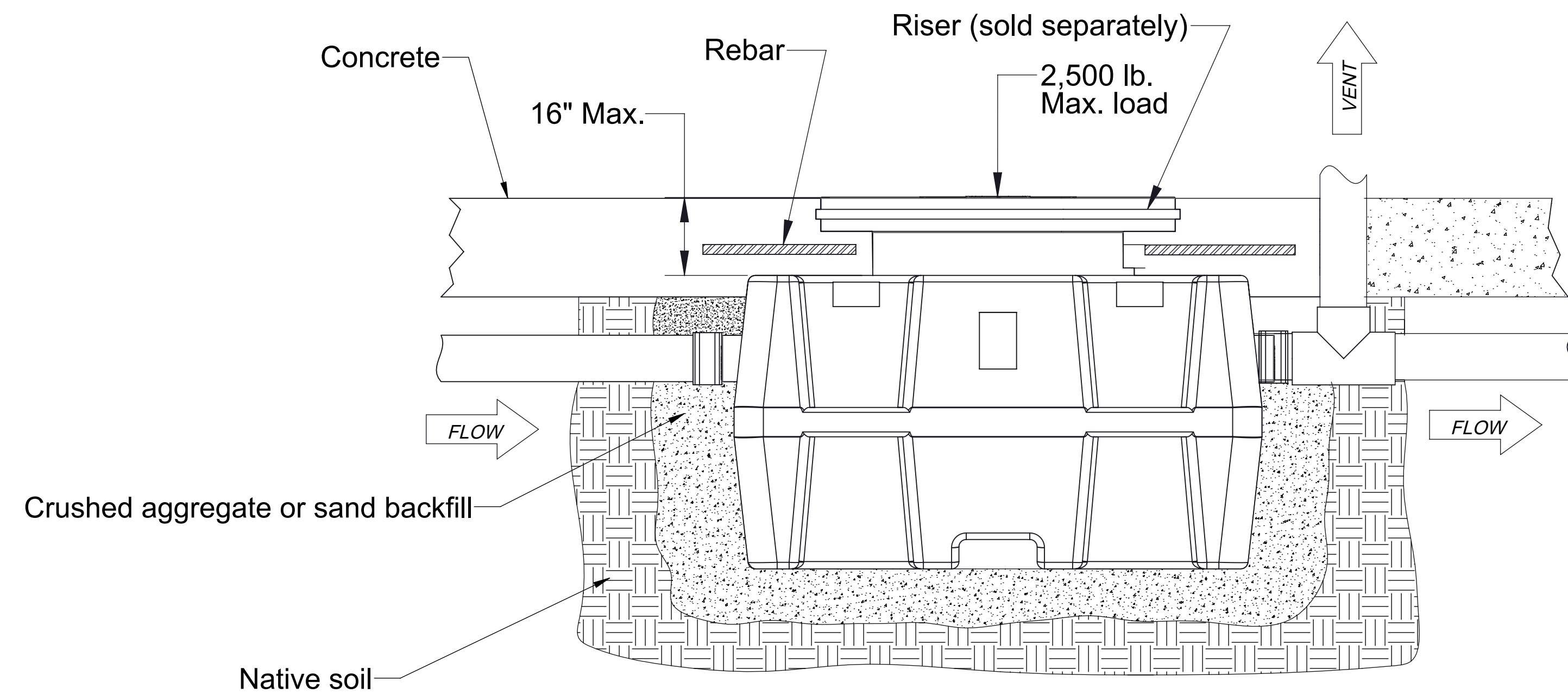

**OS-25 Shown with riser**

If concrete slab falls within body of unit, reinforce with rebar, extending 6" beyond footprint of unit to connect main floor slab.

## INTERIOR ABOVE GRADE INSTALLATION INSTRUCTIONS (OS-15, OS-25, OS-35, OS-50, OS-75, OS-100, OS-500)

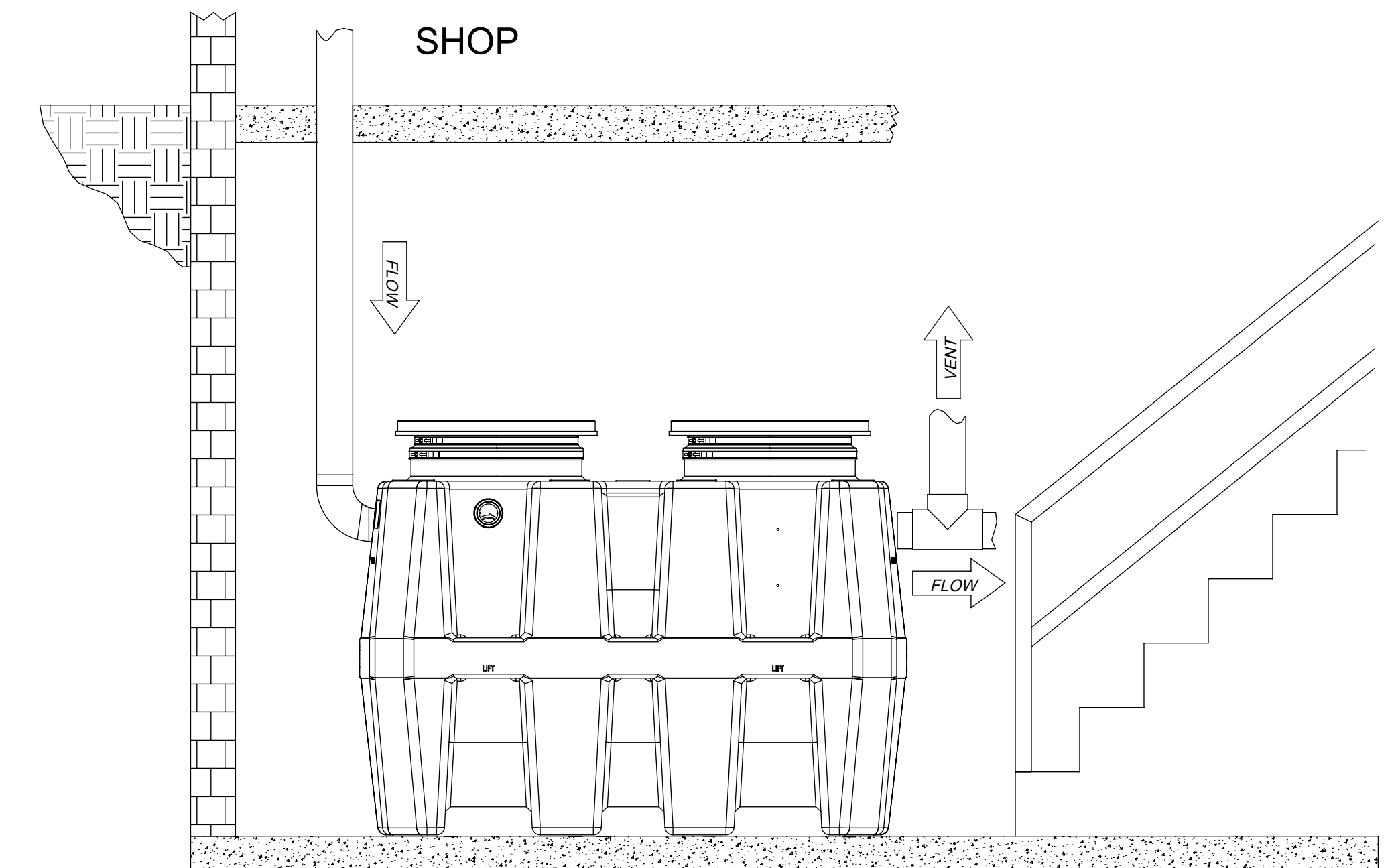

**ON-THE-FLOOR DETAIL**

(OS-100 SHOWN)

Install unit(s) as close as possible to fixtures/drains being serviced.

### CONNECTIONS

Connect waste piping to the unit.

### SET OIL DRAW OFF

If unit is ordered with optional oil draw-off connection, see sheet #5 for correct settings.

### NOTES:

Striem oil separators are rated and manufactured with an internal flow control system already in place. They do not require an external flow control system or air intake vent.

Striem oil separators are not to be installed in any other manner except as shown. Consult local codes for separate trapping requirements, cleanout locations and additional installation instructions.

PROPRIETARY AND CONFIDENTIAL  
THE INFORMATION CONTAINED IN THIS DRAWING IS THE SOLE PROPERTY OF STRIEM, LLC. ANY REPRODUCTION IN PART OR AS A WHOLE WITHOUT THE WRITTEN PERMISSION OF STRIEM, LLC. IS PROHIBITED.

DESCRIPTION:  OS & OCT SERIES INSTALLATION, OPERATION AND MAINTENANCE GUIDE				<b>Striem</b> 3100 Brinkerhoff Kansas City, KS 66115 Tel: 913-222-1500 Fax: 913-291-0457 www.striemco.com  Made in the U.S.A	
SHEET NUMBER: 4 of 7					
DWG BY: MJ	DATE: 8/15/18	REV:	ECO:		

**INSTALLATION INSTRUCTIONS**

1. Install unit(s) as close as possible to OS Series tank.
2. OCT tank installation is identical to similar sized OS tanks. See Sheets #2 through #4, and sheets #7 and #8 for TeleGlide installation.

**CONNECTIONS**

1. Connect vent pipe and spill line as shown.
2. Install an additional vent on the outlet pipe of the OS unit.
3. Adjust Oil Draw-Off arm between 1/4" to 1/2" above operating water line.

**Oil Collection Tank Installation  
(OCT-50, OCT-125, OCT-275)**

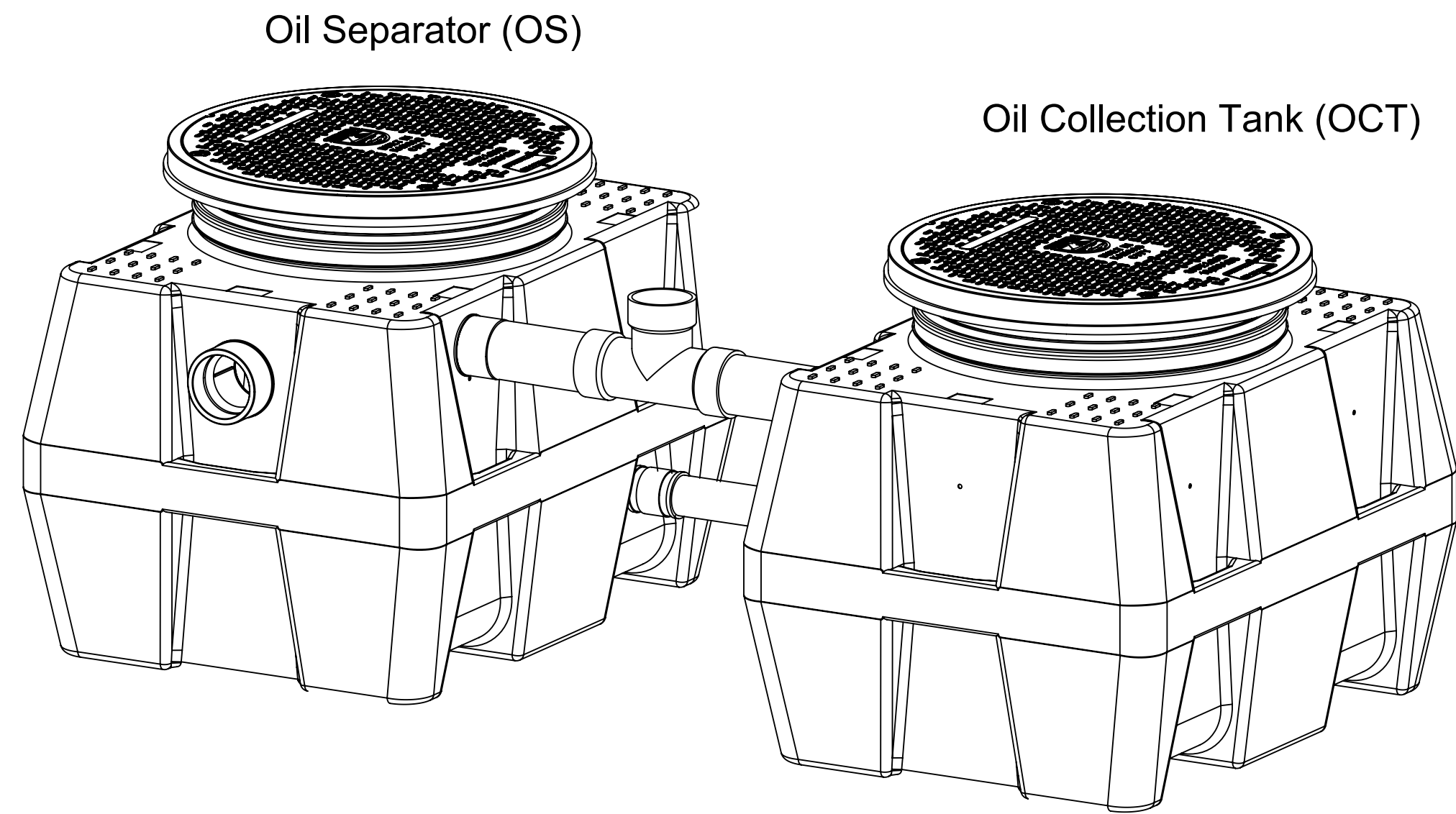

**OIL DRAW-OFF (OPTIONAL)**

Striem Oil Separators may be ordered with a 1-1/2" draw-off unit consisting of an adjustable draw-off tube and slip-nut. In order for the Oil Separator to work properly, the oil draw-off must be adjusted to meet the correct operating height for the flow of the unit. The oil draw-off unit leads separated oil into an oil drainage line and collection tank, where it can be taken care of properly (See OCT Series).

Once the Oil Separator is installed, an operating water level must be established. Remove covers and run water through separator at maximum flow rate. Move adjustable draw-off tube between 1/4" to 1/2" above operating water line. If discharged oil contains water, raise adjustable tube until only oil is being removed. Draw-off setting must be checked periodically. If draw-off tube is properly set, water will not draw off with oil.

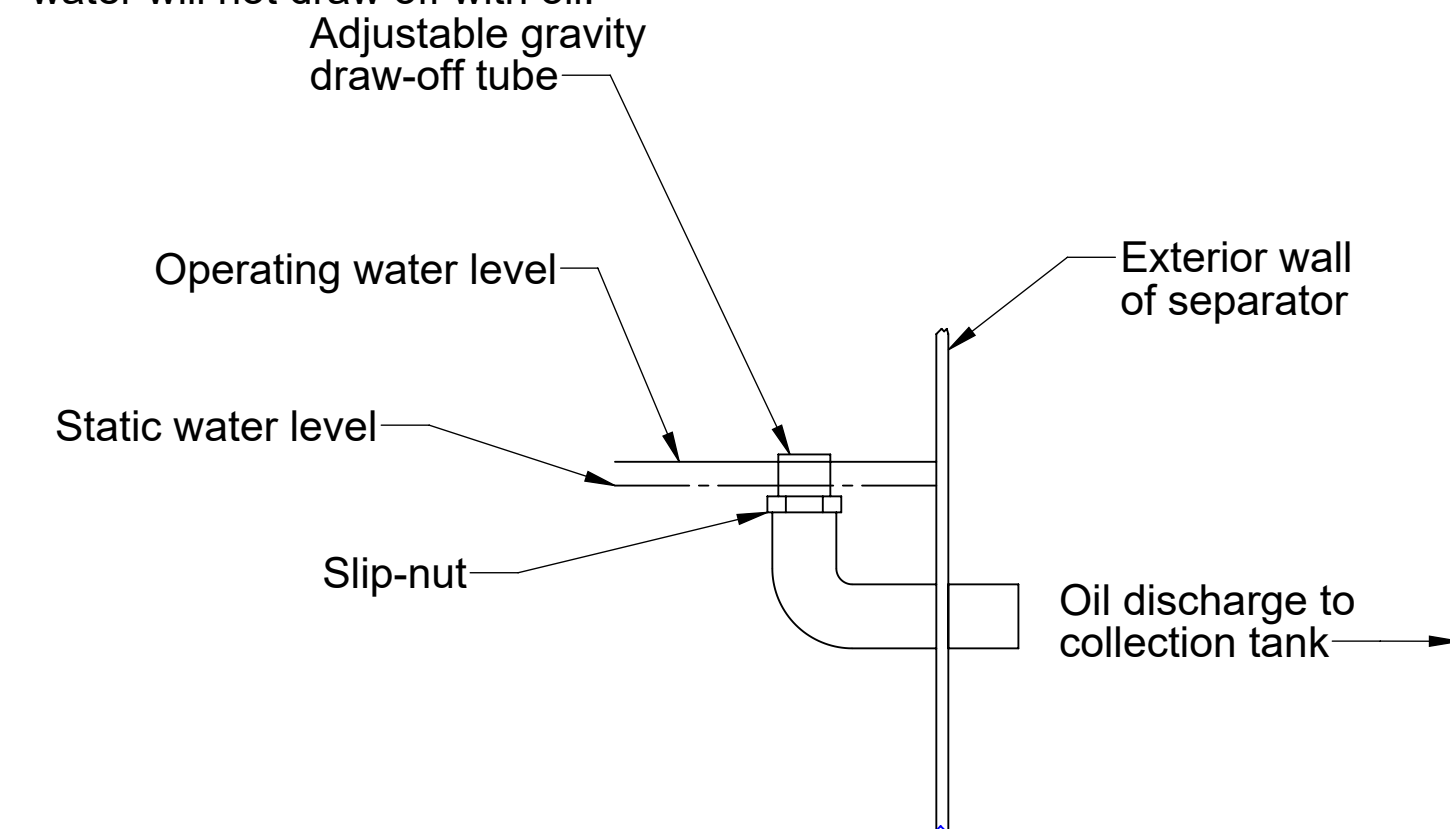

**PUMPING FREQUENCY:**

Frequency depends on the capacity of the interceptor and the amount of oil and sediment in the wastewater.

After initial installation, it is recommended that the unit is pumped every 3 to 4 weeks. Monitor each pumping to establish an adequate maintenance Striem recommends pumping frequency not to exceed more than 6 months.

**NOTES:**

Striem oil separators are rated and manufactured with an internal flow control system already in place. They do not require an external flow control system or air intake vent.

Striem oil separators are not to be installed in any other manner except as shown. Consult local codes for separate trapping requirements, cleanout locations and additional installation instructions.

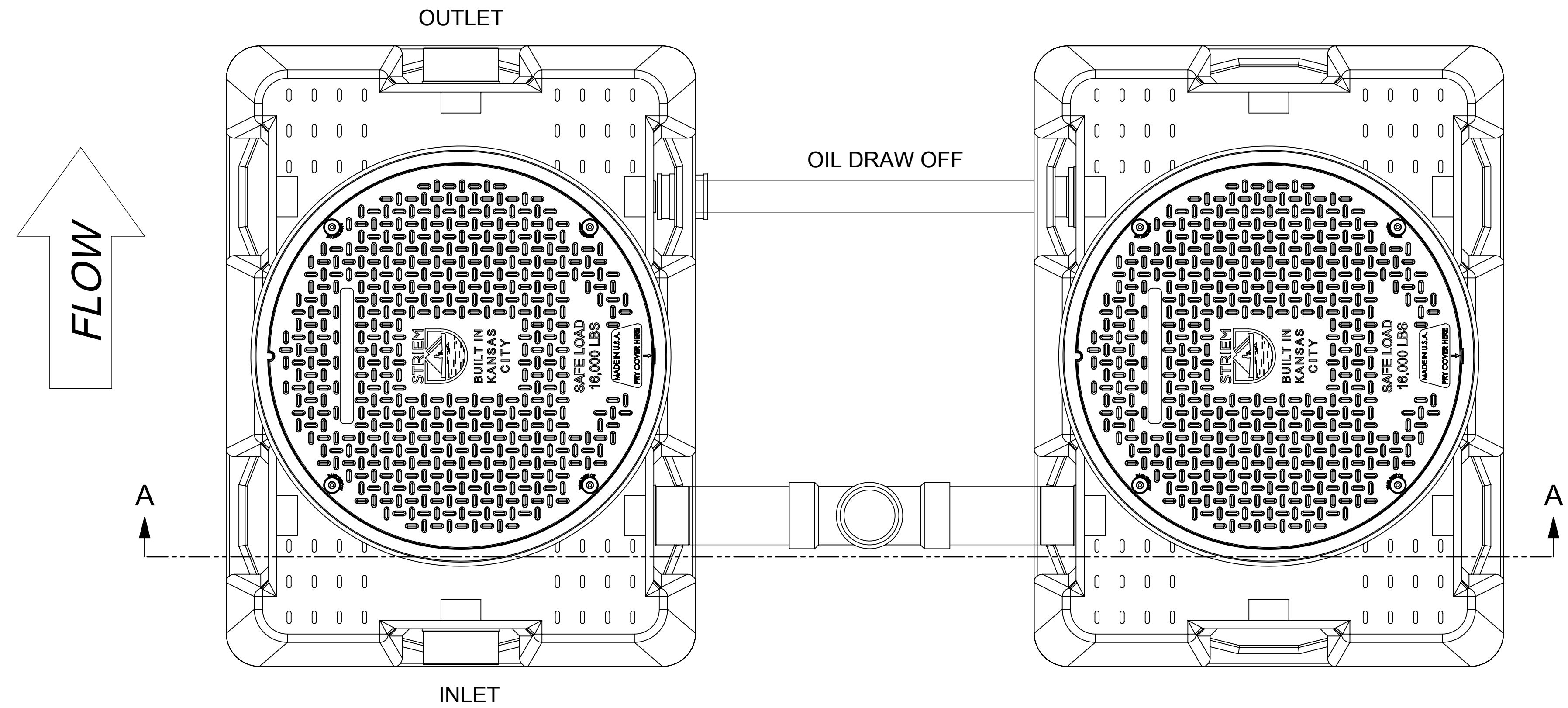

**Oil Separator (OS)**

**Oil Collection Tank (OCT)**

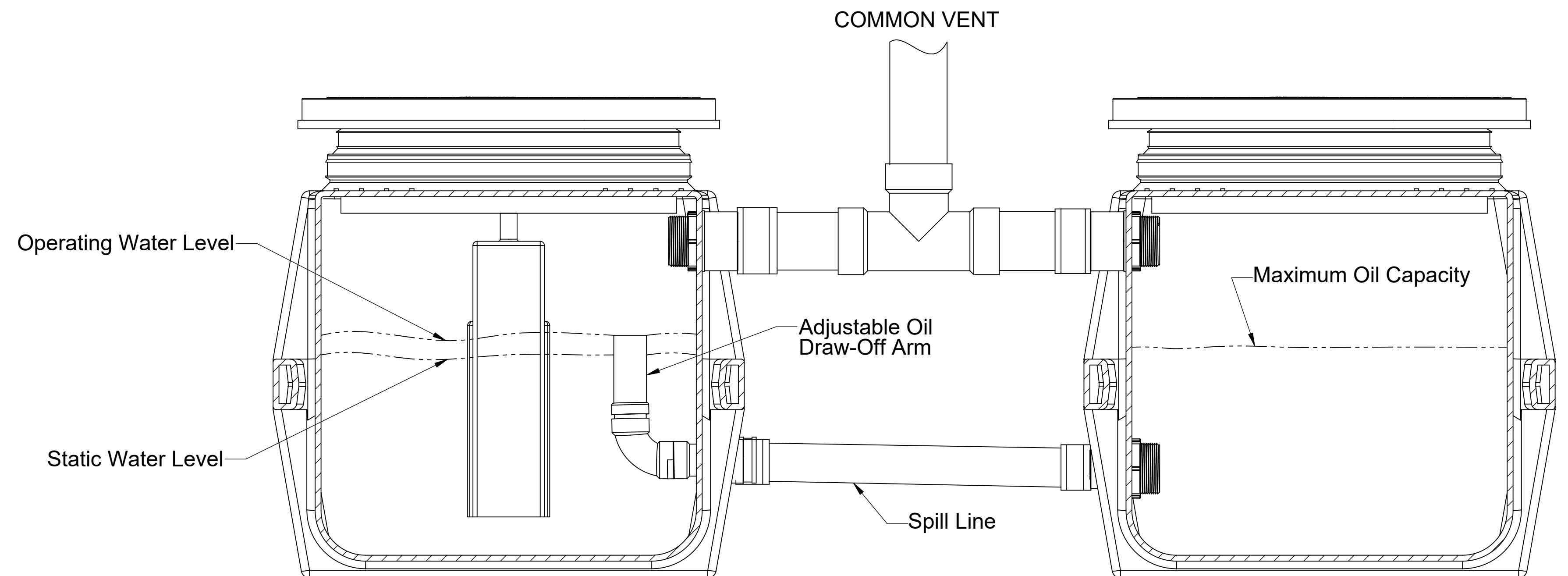

<b>DESCRIPTION:</b>			
OS & OCT SERIES INSTALLATION, OPERATION AND MAINTENANCE GUIDE			
<b>SHEET NUMBER:</b> 5 of 7			
<b>DWG BY:</b> MJ	<b>DATE:</b> 8/15/18	<b>REV:</b>	<b>ECO:</b>

**Striem**  
3100 Brinkerhoff  
Kansas City, KS 66115  
Tel: 913-222-1500  
Fax: 913-291-0457  
www.striemco.com  
  
Made in the U.S.A



PROPRIETARY AND CONFIDENTIAL  
THE INFORMATION CONTAINED IN THIS DRAWING IS THE SOLE PROPERTY OF STRIEM, LLC. ANY REPRODUCTION IN PART OR AS A WHOLE WITHOUT THE WRITTEN PERMISSION OF STRIEM, LLC. IS PROHIBITED.

**Tools included (with base grease interceptor unit(s))**

- 7/16" Nut driver tool/bit
- Silver permanent marker

**Tools Needed:**

- Tape measure
- Regular or cordless drill with 1/2" chuck

**Tools needed if Riser(s) require cutting:**

- Jigsaw or
- Cordless circular saw or
- Reciprocating saw

**Riser Assembly Instructions/Steps:**

1. If unit is to be installed on grade (on-the-floor), there is no need for any adjustments. Unit is ready to be put into service.
2. If unit is to be buried: Once unit is set so that the pipe connections line up with jobsite piping, measure total riser height needed from top of cover to finished grade. Make sure you include any future tile work, etc. that may be installed in your finished grade measurements. See figure 1.
3. Select according riser(s) needed based off Table 1.
4. If riser(s) is needed, remove cover(s) from adapter and remove adapter from main unit by loosening upper clamp with included nut driver bit (lower band is factory set do not adjust or remove). On the floor near the unit, insert adaptor into first riser until it stops. If needed, insert bottom of first riser into top of second riser until it stops. You may need to tighten upper clamps during this step to keep risers from shifting. Adapter and riser(s) should sit level with each other. Removal of cover during this process will ease assembly.
5. From the top of the adapter, measure your needed total riser height downward to the sidewall of the riser. Then, add 5" (for OS-35 or OS-50) or 6" (for OS-75, or OS-100). For example, if you have a OS-100 and need a 15-1/2" extension, you would measure down from the top of the adapter 21-1/2" (15-1/2" + 6" = 21-1/2"). See Figure 2.
6. Refer to Table 2, Table 3 or Table 3a to determine if, and where, any cuts need to be made. If a cut needs to be made, make a circular line around the sidewall of the riser with the included silver marker at your riser height + dimension from step 5. Using a jigsaw, circular saw or reciprocating saw, cut along your line. Discard/recycle the cutoff scrap.
7. Whether the riser needs to be cut or not, make another mark with the silver marker on the sidewall of the riser a distance of 4 INCHES (3 INCHES for a OS-35 w/ 4" connections) above the edge just cut. If you did not make a cut (meaning your riser height + dimension from step 5 line was beyond the bottom edge of your riser), still mark the sidewall of the riser 4 INCHES above where your riser height + dimension from step 5 line would have been. DO NOT cut this new line. Once the riser is installed into the main unit, this new line will end up at the top of the gasket and will aid in re-assembly. See Figure 3.
8. IMPORTANT: Before the next step: Make sure both diffusers are installed inside the main unit at the appropriate locations and check if there needs to be any flow control adjustment on the inlet diffuser. Refer to sheet 2 of the installation instructions for flow control adjustment.
9. Refer to sheet 1 of the installation instructions for leak/water testing procedures.
10. Take riser(s) and adapters apart to reduce the weight during installation. Wipe all sidewalls and inside of gasket with a damp cloth to remove jobsite dust/debris. Install components into the main unit starting from the lowest (cut) riser and working your way toward the finished floor level. Upper clamps at each gasket need to be loosened or removed to aid in assembly. Once riser(s)/adapter is inserted into gasket, upper clamp can be tightened.
11. Verify that the bottom of the lowest riser is protruding at least 2-1/2" but no more than 4" into the main unit from the top of the gasket. Your mark from step 7 should be at the top edge of the gasket on the main unit. If measurements were made correctly, this should happen automatically. See figure 4.
12. If tilting of the adapter is required to be flush with finished grade, it must be done AFTER all clamps have been tightened with riser(s)/adaptor in a vertical and level position. Tilting is achieved by using the flexibility of the gasket. If tilting is done before clamps are tightened, a perfect gasket seal may be compromised. Schier recommends tilting only the adapter versus the entire riser assembly to make sure your riser height is maintained.
13. Tighten all clamps to a minimum of 5 and a maximum of 8 ft lbs. of torque. Use the same torque as you would tighten a rubber no-hub coupling.
14. The adapter must be adjusted upward to achieve certain extension heights. See Table 2, Table 3 or Table 3a.
15. If jobsite riser height conditions change after the above steps have been completed, there may still be room for vertical adjustment in both directions. As long as minimum and maximum overlaps are maintained (see Figure 4), the adapter/riser(s) can be adjusted/cut as many times as necessary. Please follow these steps from the beginning to ensure the proper overlaps are maintained.

**TeleGlide Riser (24 Series) Installation Guidelines (OS-35, OS-50, OS-75, OS-100)**

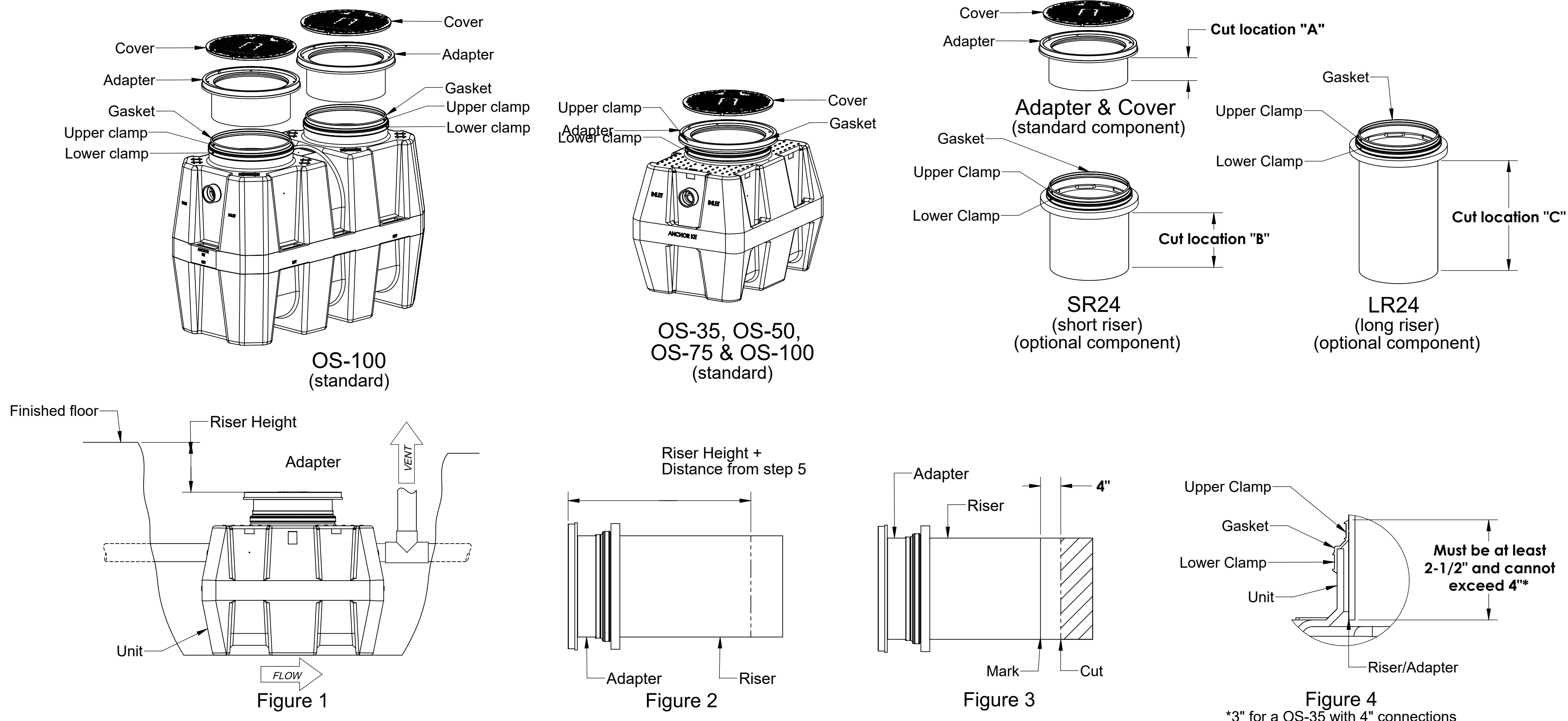

**Table 1  
TeleGlide Riser Order Guide**

OS-35 & OS-50		OS-35 w/ 4" Connections		OS-75		OS-100	
Riser Height	Riser Qty.	Riser Height	Riser Qty.	Riser Height	Riser Qty.	Riser Height	Riser Qty.
>3-1/2" to 22"	1 0	>2-1/2" to 21"	1 0	>6" to 24"	1 0	>6" to 24"	2 0
>22" to 37"	0 1	>21" to 36"	0 1	>24" to 39"	0 1	>24" to 39"	0 2
		Note: Available range of adapter only is 2-1/2".		>39" to 43"	2 0	>39" to 43"	4 0
				>43" to 58"	1 1	>43" to 58"	2 2
				>58" to 72"	0 2	>58" to 72"	0 4

**Table 3  
(for OS-35 and OS-50)**

Riser Height Needed	Riser P/N Needed	Riser Qty. Needed	Cut Location(s) (See figures above)
0" to 3-1/2"	None	0	None
>3-1/2" to 6-1/2"	SR24	1	a,b
>6-1/2" to 17"	SR24	1	b
>17" to 22"	SR24	1	None <sup>5</sup>
>22" to 32"	LR24	1	c
>32" to 37"	LR24	1	None <sup>5</sup>

**Table 3a  
(for OS-35 w/ 4" Connections)**

Riser Height Needed	Riser P/N Needed	Riser Qty. Needed	Cut Location(s) (See figures above)
0" to 2-1/2"	None	0	None
>2-1/2" to 5-1/2"	SR24	1	a,b
>5-1/2" to 16"	SR24	1	b
>16" to 21"	SR24	1	None <sup>7</sup>
>21" to 31"	LR24	1	c
>31" to 36"	LR24	1	None <sup>8</sup>

5. Adjust adapter upwards to reach 20" to 22"
6. Adjust adapter upwards to reach 35" to 37"

7. Adjust adapter upwards to reach 19" to 21"
8. Adjust adapter upwards to reach 34" to 36"

**Table 2  
(for OS-75 and OS-100)**

Riser Height Needed	Riser P/N Needed	Riser Qty. Needed		Cut Location(s)
		OS-75	OS-100	
0" to 6"	None	0	0	None <sup>5</sup>
>6" to 8-1/4"	SR24	1	2	a,b
>8-1/4" to 19-3/4"	SR24	1	2	b
>19-3/4" to 24"	SR24	1	2	None <sup>1</sup>
>24" to 35"	LR24	1	2	c
>35" to 39"	LR24	1	2	None <sup>2</sup>
>39" to 43"	SR24	2	4	b
>43" to 51-1/2"	SR24	1	2	c
	LR24	1	2	
>51-1/2" to 58"	SR24	1	2	None <sup>3</sup>
	LR24	1	2	
>58" to 66-1/2"	LR24	2	4	c
>66-1/2" to 72"	LR24	2	4	None <sup>4</sup>

1. Adjust adapter upwards to reach 22" to 24"
2. Adjust adapter upwards to reach 37" to 39"
3. Adjust adapter upwards to reach 56" to 58"
4. Adjust adapter upwards to reach 70" to 72"
5. For OS-75, Adaptor will need to be cut short at location "A" to reach 0"- 3-1/2" due to oprn top Diffuser.

Call Striem with questions or suggestions @ 1-913-222-1500 Customer Service Hours: 8AM-5PM CST

**NOTES:**

Striem oil separators are rated and manufactured with an internal flow control system already in place. They do not require an external flow control system or air intake vent.

Striem oil separators are not to be installed in any other manner except as shown. Consult local codes for separate trapping requirements, cleanout locations and additional installation instructions.

<b>DESCRIPTION:</b>			
<b>OS &amp; OCT SERIES INSTALLATION, OPERATION AND MAINTENANCE GUIDE</b>			
<b>SHEET NUMBER: 6 of 7</b>			
<b>DWG BY: MJ</b>	<b>DATE: 8/16/18</b>	<b>REV:</b>	<b>ECO:</b>

**Striem**  
3100 Brinkerhoff  
Kansas City, KS 66115  
Tel: 913-222-1500  
Fax: 913-291-0457  
www.striemco.com

Made in the U.S.A

**Tools included (with riser kit)**

- Silver permanent marker

**Tools Needed:**

- Tape measure
- Phillips head screwdriver
- Jigsaw or
- Cordless circular saw or
- Reciprocating saw

**Riser Assembly Instructions/Steps:**

1. If unit is to be buried, you will need a riser kit (sold separately). The 16 Series TeleGlide Riser System for these models allows riser heights from 2-1/8" above standard unit up to 16". Only ONE riser may be used per base unit to allow sufficient access to internal serviceable components. See Figure 5.
2. If more than 16" of riser height is needed, you will need to adjust jobsite requirements OR purchase the next available model with a 24 Series TeleGlide Riser System which allows taller riser heights.
3. Once unit is set so that pipe connections line up with jobsite piping, remove cover from unit. Fasten yellow gasketed ring to unit with hardware provided in separate riser kit. Ring flange with 4 bolt notches faces down against the unit. See Figure 1.
4. Push riser into ring until it stops (about 1 inch). See Figure 2.
5. Measure the distance from the top edge of the riser down to the finished floor. Make sure to account for any future tile work in your measurement. See Figure 2.
6. Remove riser from ring. Take measurement from step 5 from the BOTTOM of the riser upwards towards the top of the riser. Mark a line around the riser, and cut with handsaw, jig saw, or reciprocating saw. Remove debris from cut edge with scraper, utility knife, or gloves. See Figure 3.
7. Place cut riser back into ring on unit until it stops. Fasten cover from unit into riser with the same 4 bolts from the unit. Unit is ready to be water tested and backfilled. Install finished floor. See Figure 4.

**TeleGlide Riser (16 Series) Installation Guidelines (OS-15, OS-25)**

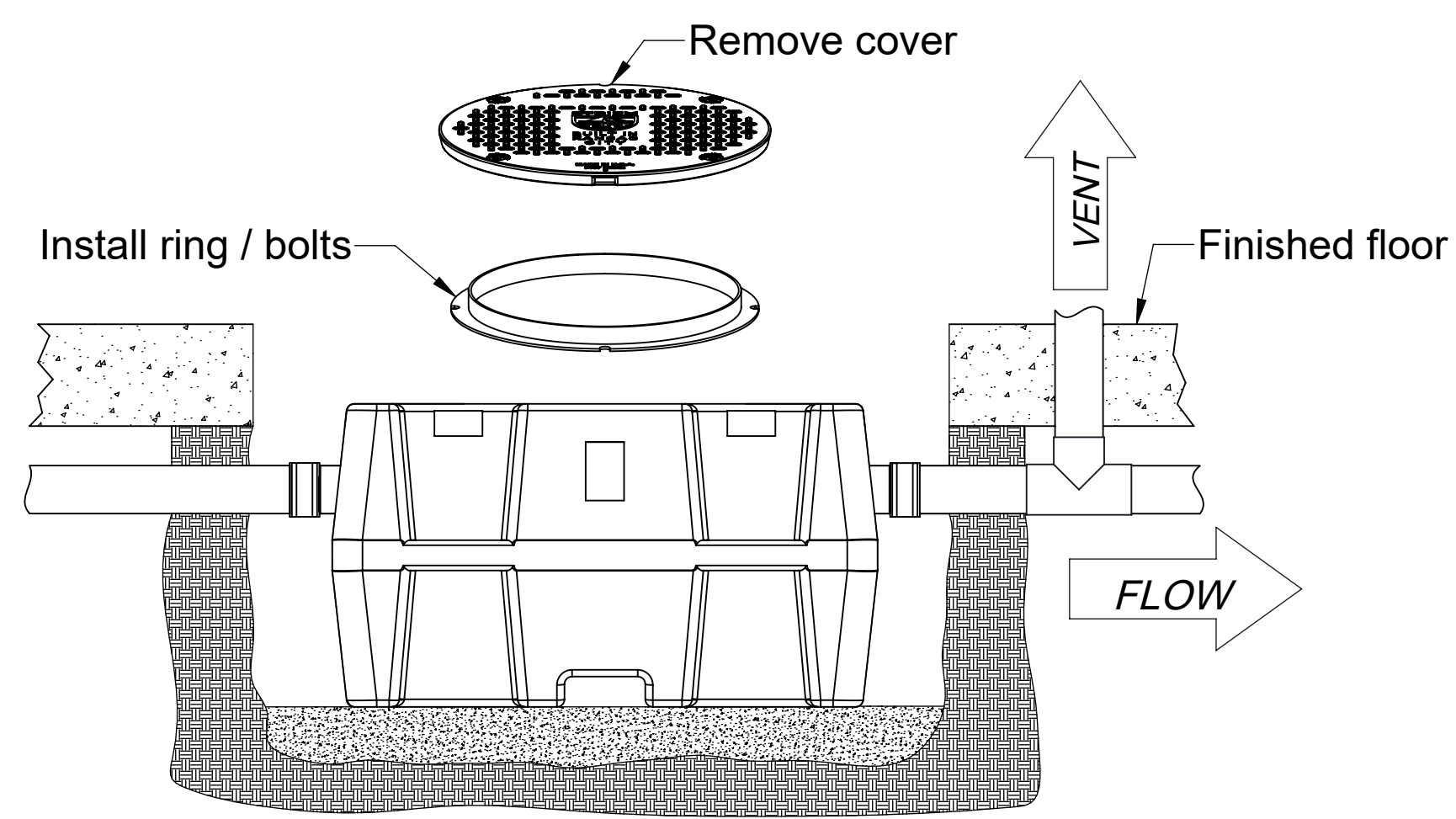
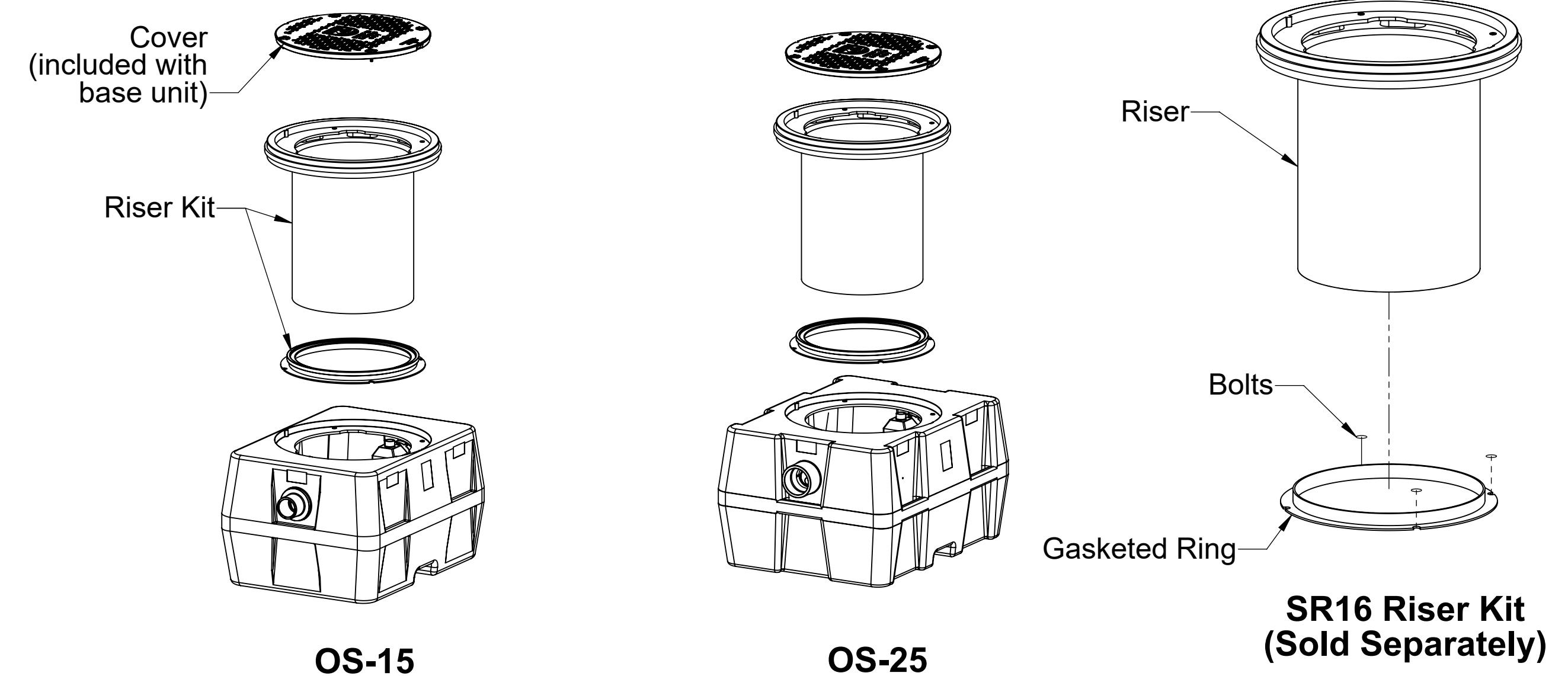

**Figure 1**

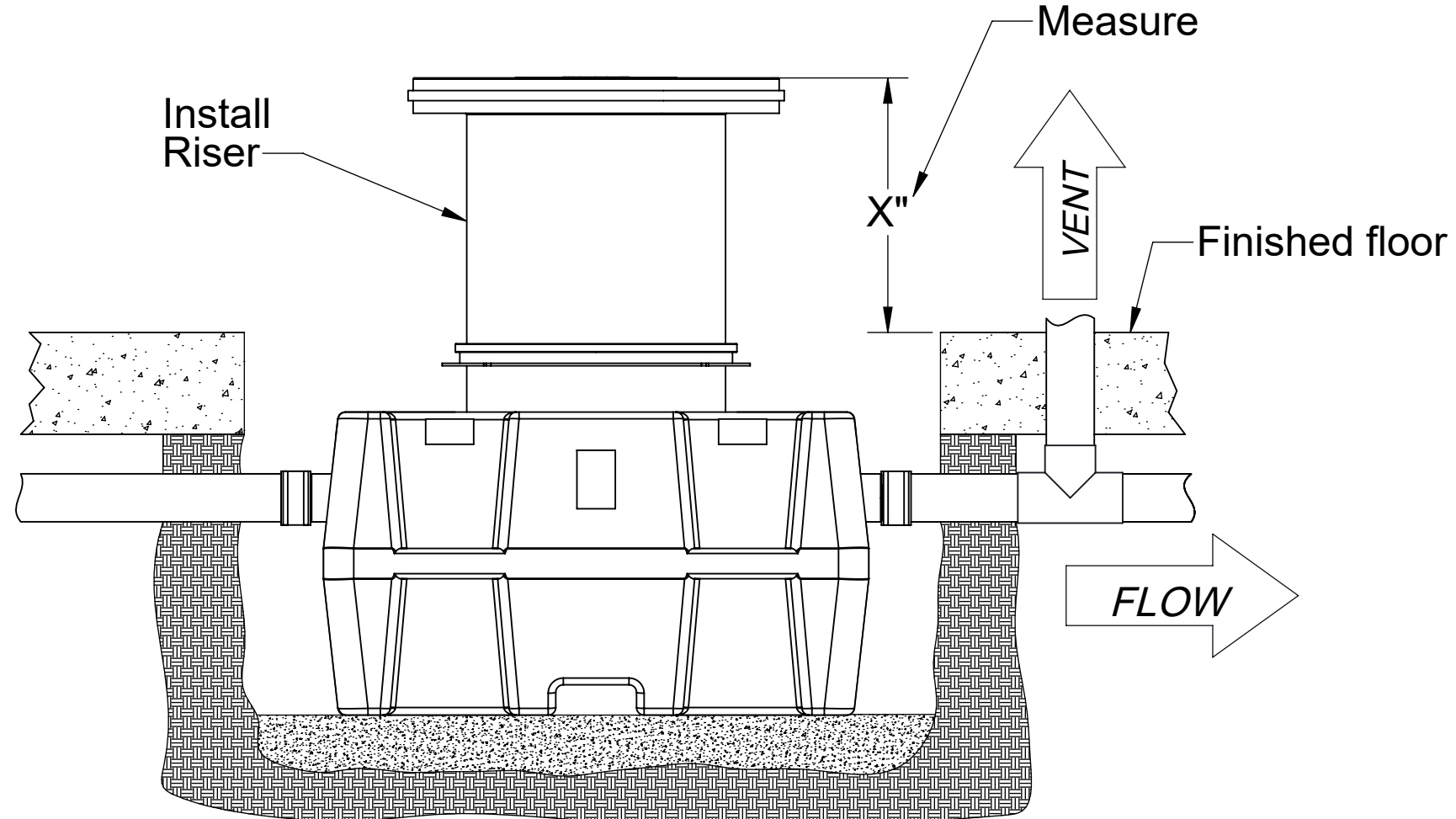

**Figure 2**

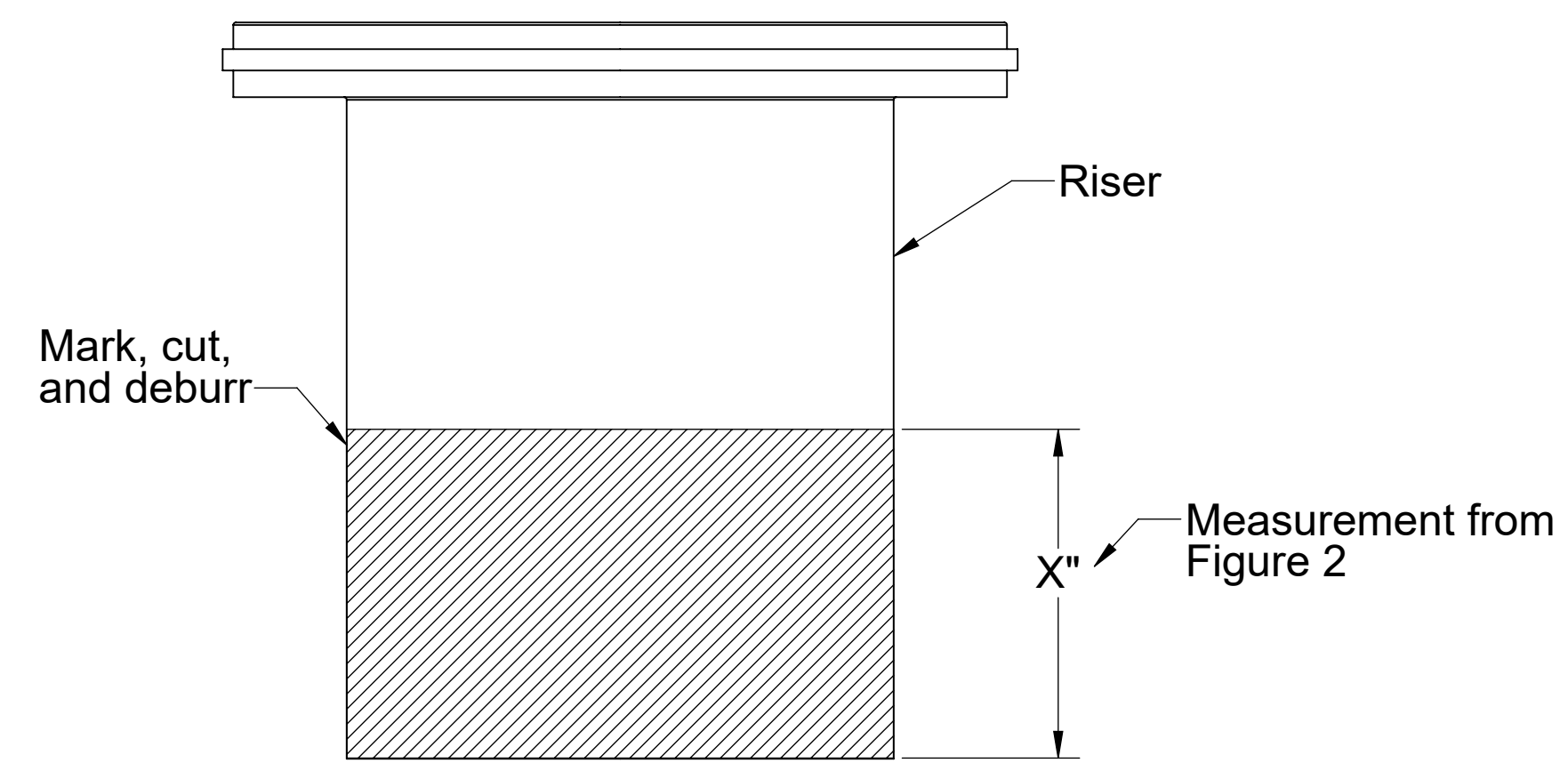

**Figure 3**

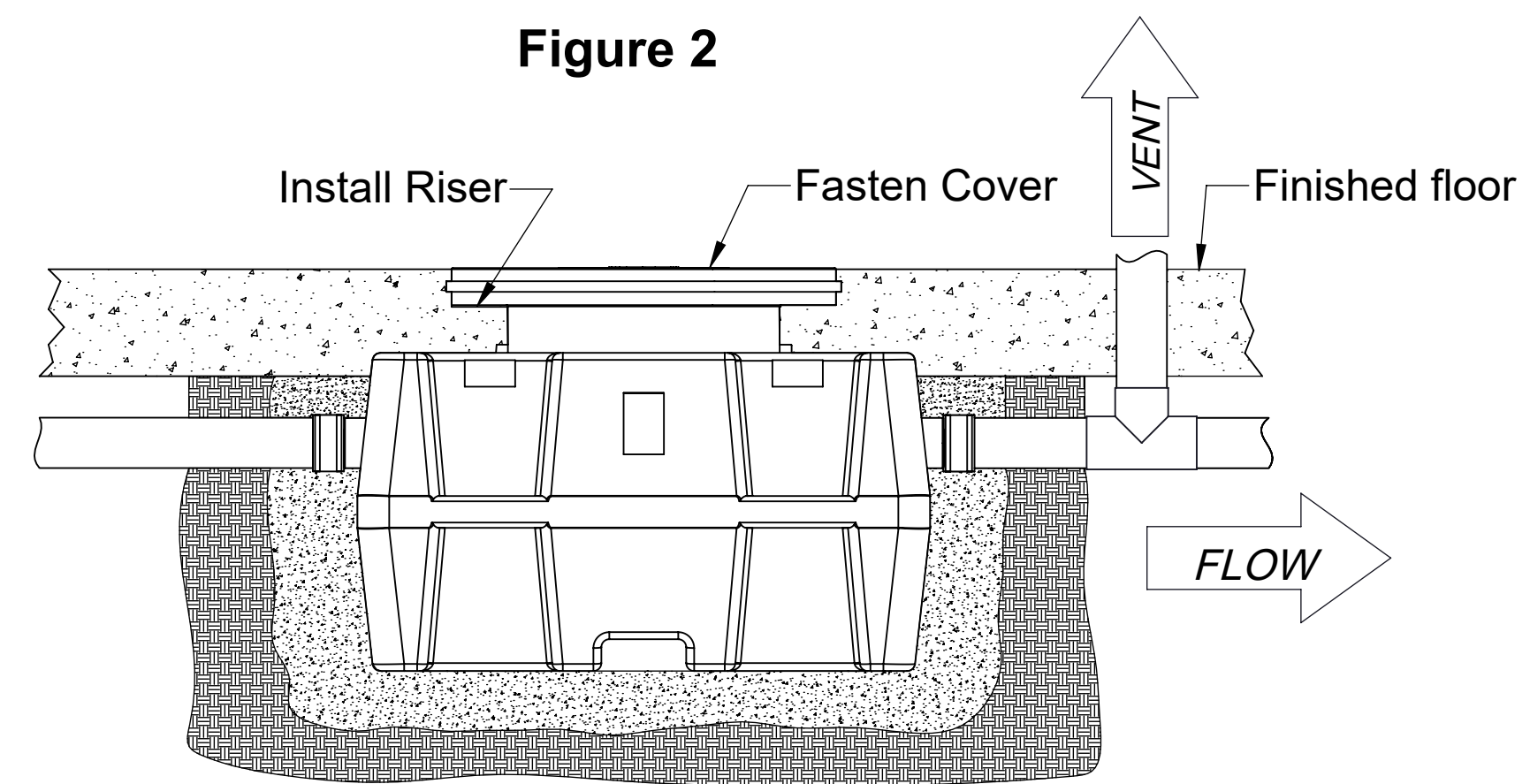

**Figure 4**

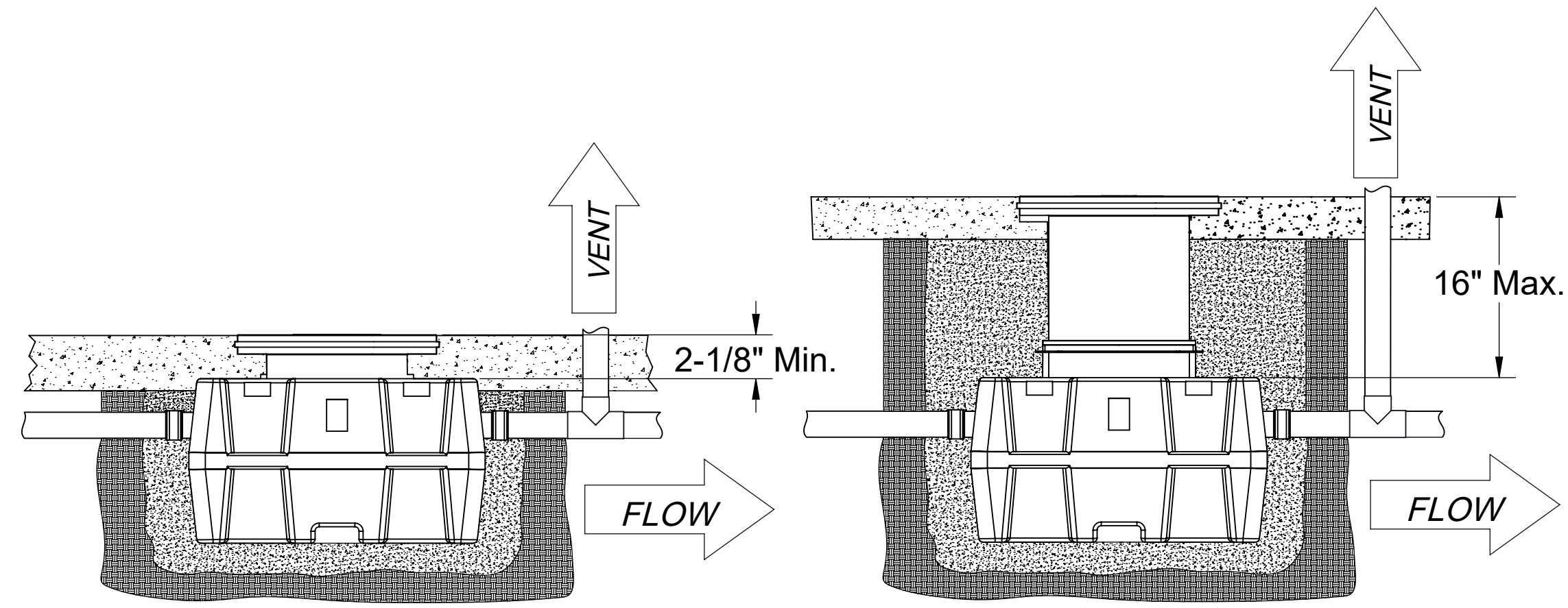

Minimum and maximum riser heights when units are buried.

**Figure 5**

**NOTES:**

Striem oil separators are rated and manufactured with an internal flow control system already in place. They do not require an external flow control system or air intake vent.

Striem oil separators are not to be installed in any other manner except as shown. Consult local codes for separate trapping requirements, cleanout locations and additional installation instructions.

PROPRIETARY AND CONFIDENTIAL  
THE INFORMATION CONTAINED IN THIS DRAWING IS THE SOLE PROPERTY OF STRIEM, LLC. ANY REPRODUCTION IN PART OR AS A WHOLE WITHOUT THE WRITTEN PERMISSION OF STRIEM, LLC. IS PROHIBITED.

<b>DESCRIPTION:</b>			
OS & OCT SERIES INSTALLATION, OPERATION AND MAINTENANCE GUIDE			
<b>SHEET NUMBER:</b> 7 of 7			
<b>DWG BY:</b> MJ	<b>DATE:</b> 8/16/18	<b>REV:</b>	<b>ECO:</b>

**Striem**  
3100 Brinkerhoff  
Kansas City, KS 66115  
Tel: 913-222-1500  
Fax: 913-291-0457  
www.striemco.com  
Made in the U.S.A

